

12468

**STATE WATER BOARD**  
**-SITE MANAGEMENT PLAN**  
**-NOA**  
**-2018 & 2019 MRP**

# Site Management Plan

## Implementation of Best Practical Treatment or Control Measures

In Fulfillment of Water Quality Order 2017-0023-DWQ

State Water Resources Control Board

APN 210-072-009

March 2020

Prepared for:  
Kurt Moffitt  
Cali's Finest Gardens, LLC  
WDID No. 1\_12CC417947  
707-502-6853

Prepared by:  
Jackson Ingram, EIT  
Job No. 18052.1  
707-633-8321



425 I Street Arcata, California 95521  
707-633-8321 | [motherearthengineering.com](http://motherearthengineering.com)

As a condition of approval for enrollment into the Water Quality Order 2017-0023-DWQ for the cultivation, processing, manufacture, or distribution of cannabis, the owner or permittee shall indemnify and hold harmless Mother Earth Engineering, Inc. and its agents and employees for any claims, damages, or injuries brought by affected property owners or other third parties due to the commercial cultivation, processing, manufacture, or distribution of cannabis for medicinal and recreational use and for any claims brought by any person for problems, injuries, damages, or liabilities of any kind that may arise out of the commercial cultivation, processing, manufacture, or distribution of cannabis for medicinal and recreational use. As the preparer, Mother Earth Engineering, Inc. is not responsible for any water quality violations.

I/we agree to be responsible to the stated terms and conditions of the Order, and release Mother Earth Engineering, Inc., its employees, contractors, and consultants from any defense costs, including attorneys' fees or other loss connected with any legal challenge which may arise from implementation of said Order.

Landowner Printed Name: Jamie Gilbert

Signature: \_\_\_\_\_ Date: \_\_\_\_\_

Discharger Printed Name: Kurt Moffitt

Signature: \_\_\_\_\_ Date: \_\_\_\_\_

Prepared by: Mother Earth Engineering, Inc.  
425 I Street  
Arcata, CA 95521  
(707) 633-8321

Site Management Plan prepared on: 04/01/2020

Signature: \_\_\_\_\_ Date: \_\_\_\_\_

---

## GENERAL INFORMATION

---

**Discharger:** Kurt Moffitt

3441 L Street

Eureka CA, 95503

**Site Address:** Bear Ridge Road

Bridgeville, CA

Humboldt County

**Parcel:** APN: 210-072-009

Zoning: (AE, TPZ) - Agricultural Exclusive, Timberland Production Zone

Parcel Size: 269.5 Acres

Cannabis Cultivation Area: 0.68 Acres

Disturbed Area: 0.8 Acres

HUC-12: 180101050901 - Butte Creek

**SWB WDID:** 1\_12CC417947

**Facility Status:** Tier 1 - Low Risk

---

**TABLE OF CONTENTS**

1	Introduction & purpose .....	3
1.1	Site Location .....	3
1.2	Site Description .....	3
1.3	Field And Assessment Methods .....	3
2	Sediment discharge bptc measures .....	4
2.1	Site Characteristics .....	4
2.2	Road Conditions .....	4
2.3	Cultivation Area .....	5
2.4	Water Resources .....	<b>Error! Bookmark not defined.</b>
2.5	Storage Areas .....	<b>Error! Bookmark not defined.</b>
2.7	Watercourses and Stream Crossings .....	6
2.8	Legacy Waste Discharge Issues .....	7
3	Sediment Erosion Prevention & Sediment Capture .....	8
3.1	Erosion Prevention BPTC Measures .....	8
3.2	Sediment Control BPTC Measures .....	9
3.3	Maintenance Activities .....	9
4	Agricultural Chemical BPTC Measures .....	10
4.1	Inventory of Agricultural Chemicals .....	10
4.2	Agricultural Chemical Storage, Application & Disposal .....	11
4.3	Spill Prevention & Cleanup .....	11
5	Petroleum Product BPTC Measures .....	11
5.1	Inventory of Petroleum Products .....	11
5.2	Petroleum Product Storage, Use & Disposal .....	11
6	Spill Prevention and Cleanup .....	<b>Error! Bookmark not defined.</b>
7	Trash/Refuse and Domestic Wastewater BPTC Measures .....	12
7.1	Inventory of Refuse Sources On Site .....	12
7.2	Inventory of Wastewater Sources On Site .....	12
8	Winterization BPTC Measures .....	12
9	Corrective Actions Table .....	<b>Error! Bookmark not defined.</b>

---

## 1 INTRODUCTION & PURPOSE

---

This Site Management Plan (Plan) was developed to report how the discharger is complying with the Best Practicable Treatment or Controls (BPTC's) listed in Attachment A, Section 2 of the State Water Resources Control Board (SWRCB) Order WQ 2019-0001-DWQ (Order). The purpose of this Order is to provide a regulatory structure to minimize adverse impacts to water quality due to cannabis cultivation. Cannabis cultivators that are enrolled under this Order and compliant with its regulations will receive a conditional waiver for the discharges associated with cannabis cultivation. Using data from on-site assessments and office analysis; this Plan provides an inventory of all cannabis cultivation activities, land and resource management, and land stewardship practices to ensure the discharger is in compliance with the Order.

### 1.1 SITE LOCATION

The 269.50-acre site is located in the Butte Creek subwatershed in southeastern Humboldt County approximately 9 miles southeast of Bridgeville. The Lower Van Duzen watershed is within the Van Duzen hydrologic area and Eel River Hydrologic Unit. To reach the site from Eureka, take US-101 S to CA-36 E and continue for 34 miles. Turn right onto China Mine Camp Road and after 0.87 miles, turn right again on Bear Ridge Road. Property is on the right with a southeastern aspect. The site is located in Section 25, Township 1N, Range 4E, Humboldt Basin Meridian. The property is located on the Larabee Valley USGS 7.5-minute quadrangle map.

### 1.2 SITE DESCRIPTION

The property is located on the ridgeline of the rolling hills of Larabee Valley and ranges from 2,450 to 2,920 feet above mean sea level, surrounded by Oregon white oak dominated woodland and Douglas fir dominated coniferous forest. The land is characterized as having low sloped grades of less than 15% slopes to medium sloped grades up to 50% slopes. Project areas on the property is situated at the top of a hill and generally drains south towards the of the property into Mule Creek. Mean annual precipitation is 71.64 inches (Caltrans). According to Web Soil Survey, two (2) soil types are mapped on the property. Soils within the property are primarily composed of the Pasturerock-Coyoterock-Maneze complex, 15 to 50 percent slopes, dry, and the Highyork-Elkcamp-Airstrip complex, 15 to 30 percent slopes (NRCS, 2019). These soils are considered deep, well-drained soils that formed in colluvium derived from sandstone, mudstone and material weathered from chloritic schist. They are not considered hydric soils.

Mule Creek, a Class II watercourse, flows across the southern portion of the parcel approximately 1,550 feet south of the nearest cultivation area from the creek's streamside management area. Butte Creek, another Class II watercourse runs outside the property's parcel approximately 2,270 feet to the east. The Butte Creek sub watershed contains habitat for Northern California coast winter and summer steelhead (*Oncorhynchus mykiss irideus*), which are special-status species (University of California at Davis 2014). According to CDFW's California Natural Diversity Database (CNDDB), the following special-status species have been historically observed within one (1) mile of the property project area: foothill yellow-legged frog (*Rana boylei*), American peregrine falcon (*Falco peregrinus anatum*), Pacific gilia (*Gilia capitata ssp. pacifica*), and the Northern spotted owl (*Strix occidentalis caurina*).

### 1.3 FIELD AND ASSESSMENT METHODS

Office analysis and field inventory were used to determine the status of the property for enrollment in the Order. Pre-field inspection using aerial footage of the property was used to identify existing infrastructure, cultivation areas, watercourses, and the general layout of the property. The field inventory was conducted by Mother Earth



Engineering staff on February 26, 2020. The inventory included GPS mapping of structures, water tanks, ponds, roads, cultivation sites, and other infrastructure.

## 2 SEDIMENT DISCHARGE BPTC MEASURES

### 2.1 SITE CHARACTERISTICS

Included with this report is an up to date map showing access roads, vehicle parking areas, streams, stream crossings, cultivation site(s), disturbed areas, buildings, and other relevant site features. See Appendix \_.

### 2.2 ROAD CONDITIONS

The private access road is approximately 1.2 miles long and is accessed from CA-36. An inventory of the private access road and the public roads to the property are given below in Table-1.

Table 1: Inventory of access roads on site.

Roadway	Distance (mi.)	Type / Description	Condition	Improvements
Private Access Road – China Mine Road	0.87	Compacted earth road used year round	Fair	Add ditch relief culvert DRC-1 between CV-4 & CV-6.
Private Access Road – Bear Ridge Road	0.66	Compacted earth road used year round	Fair	Add water bars on reach from cultivation area to well.

† Reference photos are located in Appendix A.

The main access road is used by residents, employees and adjacent properties with easement. On average, China Mine Road is utilized by ten properties in addition to the Owners property. Assuming two trips a day per property, China Mine Road is used roughly 22 times a day during the growing season and during the winter season. The access road, Bear Ridge Road, is on average used twice a day during the winter season. With four employees plus the owner on site during the growing season, Bear Ridge Road can expect two trips a day per person, or ten trips per day total at minimum.

Gradients on private access roads range from 10%-23%. Stormwater is drained from the access roads mainly by outsloping, insloping inside ditches, drainage relief culverts and drainage relief fords (Photo 3) . It is also proposed that the Owner crown the road where applicable to prevent potholing along China Mine Road.

Proposed improvements included the installation of a water bar along the reach of Bear Ridge Road between the cultivation areas and the well and tank array. Additionally, a water bar shall be installed on the reach of road between the rocked ford and the turnoff for the irrigation pond.

In addition to proposed water bars, a ditch relief culvert is proposed for the reach of China Mine Road between the proposed culverts CV-4 and CV-6. An inventory of the ditch relief culverts on the access roads is provided in Table 2. The ditch relief culvert is proposed to relieve the roadside ditch that frequently holds water and pools.

Table 2: Inventory of the ditch relief culverts and associated characteristics.

Map ID	Location	Material	Comments
DRC-1	40.4318, -123.6790	CMP	Existing culvert needs rock armoring installed around the inlet and outlet of the culvert.
DRC-2	40.4343, -123.6761	CMP	Proposed culvert to be installed with rock armoring around the inlet and outlet of the culvert.
RF-1	40.4320, -123.6798	Rocked	Existing rocked drainage relief ford in good condition.

### 2.3 CULTIVATION AREA

There are 11 hoop houses located in the property's cultivation area. The cultivation area is inventoried in Table 2.

Table 3: Inventory of the cultivation area and associated characteristics.

Map ID	Cultivation Area (ft <sup>2</sup> )	Area Description	Cultivation Area Slope (%)	Distance to Water Body (ft)	Nearest Water Body Classification
1	3,000	Mixed Light Hoophouse	<15%	>200 ft	Unnamed Class III - WC-1
2	3,000	Mixed Light Hoophouse	<15%	>200 ft	Unnamed Class III - WC-1
3	3,000	Mixed Light Hoophouse	<15%	>200 ft	Unnamed Class III - WC-1
4	2,400	Mixed Light Hoophouse	<15%	>200 ft	Unnamed Class III - WC-1
5	3,600	Mixed Light Hoophouse	<15%	>200 ft	Unnamed Class III - WC-1
6	1,600	Mixed Light Hoophouse	<15%	>200 ft	Unnamed Class III - WC-1
7	2,000	Mixed Light Hoophouse	<15%	>200 ft	Unnamed Class III - WC-1
8	3,000	Mixed Light Hoophouse	<15%	>200 ft	Unnamed Class III - WC-1
9	2,400	Mixed Light Hoophouse	<15%	>200 ft	Unnamed Class III - WC-1
10	2,400	Mixed Light Hoophouse	<15%	>200 ft	Unnamed Class III - WC-1
11	3,600	Mixed Light Hoophouse	<15%	>200 ft	Unnamed Class III - WC-1

† Reference photos are located in Appendix A.



## 2.4 WATERCOURSES AND STREAM CROSSINGS

There are seven (7) watercourses running through the site. An inventory of watercourses can be found in Table 4.

Table 4: Inventory of watercourses that run through the site.

Map ID	Type	Notes
WC-1	Unnamed Class III	Intermittent watercourse on the eastern side of the property draining east towards and into another unnamed intermittent watercourse (WC-4) that is tributary to Butte Creek. (P) CV-7 conveys WC-1 across China Mine Road.
WC-2	Unnamed Class III	Intermittent watercourse on the eastern side of the property draining east towards and into another unnamed intermittent watercourse (WC-4) that is tributary to Butte Creek. A stream crossing, CV-6, conveys this watercourse across China Mine Road.
WC-3	Unnamed Class III	Intermittent watercourse on the eastern side of the property draining east towards and into another unnamed intermittent watercourse (WC-4) that is tributary to Butte Creek. A stream crossing, CV-4, conveys this watercourse across China Mine Road.
WC-4	Unnamed Class III	Intermittent watercourse on the eastern side of the property draining south that is tributary to Butte Creek.
WC-5	Unnamed Class III	Intermittent watercourse on the western side of the property draining southeast and is tributary to Mule Creek. A stream crossing, CV-1, conveys this watercourse across China Mine Road.
WC-6	Unnamed Class III	Intermittent watercourse on the eastern side of the property draining southeast and is tributary to Mule Creek. A stream crossing, CV-3, conveys this watercourse across China Mine Road.
Mule Creek	Class II	A segment of Mule Creek runs across the southern portion of the property from west to east and is tributary to Butte Creek.

† Reference photos are located in Appendix A.

There are seven (7) stream crossings on site. An inventory of all stream crossings can be found in Table 5. An LSA notification has been submitted for all stream crossings.

Table 5: Inventory of all stream crossings on site.

Map ID	Type	Size	Material	100 Year Size	Comments
CV-1	Culvert	18"	Corrugated Metal Pipe (CMP)	54"	Culvert conveys a Class III watercourse (WC-5) with signs of scour, abrasion and channel degradation. Needs to be replaced, realigned with native channel.
CV-2	Culvert	20"	CMP	18-24"	CV-2 is rusted with lots of scour and degraded road base. Outlet exposed due to erosion caused by road runoff. Needs to be replaced.
CV-3	Culvert	14"	CMP	27"	Culvert conveys a Class III watercourse (WC-6). CV-3 has a crushed barrel with signs of erosion downstream due to road runoff and scour. Needs to be replaced.
CV-4	Culvert	12"	CMP	24"	Culvert conveys a Class III watercourse (WC-3). CV-4 needs replacement and an inboard ditch to hydrologically disconnect roads upslope and downslope.
CV-5	Culvert	18"	CMP	18"	Culvert conveys a Class III watercourse (WC-1).
CV-6	Culvert	24"	CMP	24"	Culvert conveys a Class III watercourse (WC-2). Severe erosion at outlet, rock armoring needed.
(P) CV-7	Culvert	30"	CMP	30"	Culvert proposed to convey WC-1 across China Mine Road and alleviate flow through CV-6.

† Reference photos are located in Appendix A.

## 2.5 LEGACY WASTE DISCHARGE ISSUES

Due to the site’s location within Regional Water Quality Control Board Region 1, legacy waste discharge issues must be identified and discussed in the Site Management Plan. There are two legacy waste discharge issues on site. Table 6 lists the known legacy waste issues located on site.

Table 6: Inventory of legacy waste issues located on site.

Map ID	Type	Notes
CV-1	Incorrectly installed culvert crossing China Mine Road	Culvert not installed to native streambed; heavy erosion has created a new streambed. This culvert is not used to access cannabis cultivation areas at the site and as such is not under jurisdiction of the Order.
CV-6	Incorrectly installed culvert crossing China Mine Road	Stream crossing accommodates two watercourses and is not sized correctly. Heavy erosion at outfall.

† Reference photos are located in Appendix A.

Culvert CV-1 was not installed in line with the native streambed, and as a result, the flow passing through this stream crossing cut and eroded a new streambed. Culvert CV-1 needs to be upgraded to be able to accommodate the peak flows from the 100-year design storm while maintaining a headwater to depth ratio of 0.67 and reinstalled to the native streambed with rock armoring for 3-6 feet downstream of the outlet to prevent further erosion.

Culvert CV-6 was installed correctly, however, flow from two separate watercourses was routed through this stream crossing, rendering it incapable of handling the peak flow of the 100-year design storm. Heavy erosion resulted at the outlet. This stream crossing needs rock armoring for 3-6 feet downstream of the outlet to prevent further erosion. The proposed stream crossing CV-7 will relieve the flows through this stream crossing by channeling one of the two watercourses back through its native streambed.

### 3 SEDIMENT EROSION PREVENTION & SEDIMENT CAPTURE

#### 3.1 EROSION PREVENTION BPTC MEASURES

Erosion prevention controls such as straw mulch, plastic covers, slope stabilization, soil binders, culvert outlet armoring, and revegetation efforts shall be inventoried and monitored to ensure their effectiveness. A complete inventory of existing and pending erosion prevention controls is listed in Table 7.

Table 7: Inventory of all existing and pending erosion prevention controls on site.

Map ID	Control Measure	Existing or Date to be Installed	Comments
Disturbed Areas around Cultivation Areas	Wood Chipping on exposed earth	Existing	Extensive wood chipping exists on all disturbed areas.
Cut Slopes around Cultivation Areas	Revegetation	Existing	Vegetation has been well established on sloped between flats in cultivation areas
Cultivation Greenhouses	Weed Mat	Existing	Used on greenhouse walkways.
Soil Pile	Tarping	Existing	All soil piles shall be correctly tarped while not in use and before the onset of the winter period.
Drainage Relief Ford	Rock Armoring	Existing	Outfall of drainage relief ford has been extensively armored to prevent erosion
Inside ditch	Rock armoring	Existing	Extensive armoring of inside ditches along access roads
Pond Overflow	Armored Outfall	Existing	Outfall of pond overflow has been armored to prevent erosion during pond discharge

† Reference photos are located in Appendix A. Add photos of vegetated slopes, inside ditch armoring, pond overflow

### 3.2 SEDIMENT CONTROL BPTC MEASURES

Sediment controls such as silt fences, fiber rolls, settling basins, vegetated outfalls, and hydroseeding shall be inventoried and monitored to ensure their effectiveness. A complete inventory of existing and pending erosion prevention controls is listed in Table 8.

Table 8: Inventory of all existing and pending sediment controls on site.

Map ID	Control Measure	Existing or Date to be Installed	Comments
Disturbed Areas around Cultivation Areas 2 & 3	Hydroseeding	Before Winter 2020.	All cutslopes above Cultivation Areas 2 & 3 need to be seeded and are not properly revegetated.

### 3.3 MAINTENANCE ACTIVITIES

The discharger will maintain a Road and Drainage Feature Maintenance Log and Sediment and Erosion Controls. A page of this log is included in Appendix B. Storms that produce 0.5 inches of precipitation within 24 hours or over



1 inch over the course of 7 days shall trigger an inspection of all roads, ditches, culverts and their outfalls, and any other drainage features. This same inspection shall occur prior to the onset of the wet season (e.g. September before regular rain events begin). Dischargers shall inspect the condition of the roads and drainage features. Any woody debris that is found at drainage inlets should be removed to prevent any blockages. Any sediment buildup that impacts access road or drainage feature performance shall be removed and stabilized outside of the riparian setbacks. Stabilization of sediment will be achieved by one of the following methods:

- Reused in contained vegetable or ornamental gardening beds that are located outside of the riparian setbacks.
- In contained stockpiles that are covered when not in use. These stockpiles can then be used when amending/reusing cultivation medium.
- Transported contained and covered to the closest transfer station to be green wasted.

## 4 AGRICULTURAL CHEMICAL BPTC MEASURES

### 4.1 INVENTORY OF AGRICULTURAL CHEMICALS

Table 9 lists all off the agricultural chemicals in use on site. All agricultural chemicals are currently stored in an open air awning alongside the residence. It is required that a designated agricultural chemical and pesticide storage location be designated so that it prevents those chemicals from entering the riparian setbacks or waters of the State. All chemical usage is in accordance with the label instructions. Agricultural chemicals are applied at agronomic rates. No restricted pesticides are allowed on the site.

Table 9: Inventory of all agricultural chemicals in use on site.

Agricultural Chemical Name	Agricultural Chemical Type	Method of Storage	Storage Location	Description of Use
Dyna-Gro Pro-TeKt	Fertilizer	In manufacturers container	Awning alongside residence.	Applied at agronomic rates when needed.
Botanicare Calmag	Fertilizer	In manufacturers container	Awning alongside residence.	Applied at agronomic rates when needed.
FloraNova Grow	Fertilizer	In manufacturers container	Awning alongside residence.	Applied at agronomic rates when needed.
Grow More Bloom	Fertilizer	In manufacturers container	Awning alongside residence.	Applied at agronomic rates when needed.
General Hydroponics MaxiBloom	Fertilizer	In manufacturers container	Awning alongside residence.	Applied at agronomic rates when needed.
Lost Coast Plant Therapy	Fertilizer	In manufacturers container	Awning alongside residence.	Applied at agronomic rates when needed.
Sulfur	Fertilizer	In manufacturers container	Awning alongside residence.	Applied at agronomic rates when needed.
Green Cleaner	Pesticide	In manufacturers container	Awning alongside residence.	Applied at agronomic rates when needed.



#### 4.2 AGRICULTURAL CHEMICAL STORAGE, APPLICATION & DISPOSAL

Empty agricultural chemical containers are disposed of per their label instruction. If the discharger is unsure of proper disposal method, they will contact their local Waste Management or Transfer Center Facility for instruction. Until proper disposal, empty containers will be kept in heavy-duty plastic totes or heavy-duty contractor bags stored in weatherproof shelter.

Agricultural chemicals are currently being stored underneath the awning of the residence with no secondary containment and inadequate wildlife protection. Agricultural chemicals shall be moved to a fully enclosed location with adequate secondary containment and separated from petroleum products.

#### 4.3 SPILL PREVENTION & CLEANUP

No spill kits are currently on site. Owner will purchase two spill kits and store them in both the designated fuel storage location and the pesticide and agricultural chemical storage location.

### 5 PETROLEUM PRODUCT BPTC MEASURES

#### 5.1 INVENTORY OF PETROLEUM PRODUCTS

Table 10 lists all of the petroleum products in use on site. All petroleum products shall be used and stored in a manner that prevents those chemicals from entering the riparian setbacks or waters of the State. Owner shall take all necessary measures to establish a designated fuel storage location. All petroleum product usage is in accordance with the label instructions.

Table 10: Inventory of all petroleum products used on site.

Petroleum Product	Associated Equipment	Method of Storage	Storage Location	Description of Use
Gasoline	Generators	5 gallon jerry cans	Awning alongside residence	Powering generators during cultivation season.

#### 5.2 PETROLEUM PRODUCT STORAGE, USE & DISPOSAL

Empty petroleum product containers shall be used and disposed of per label instruction. If the discharger is unsure of proper disposal method, they will contact their local Waste Management or Transfer Center Facility for instruction. Until proper disposal, empty containers will be kept in heavy duty plastic totes or contractor bags stored in weatherproof shelter.

Petroleum products are currently being stored underneath the awning of the residence with no secondary containment and inadequate wildlife protection. Agricultural chemicals should be moved to a fully enclosed location with adequate secondary containment and separated from agricultural chemicals

Both generators on site lack proper secondary containment and protection from rainfall. All generators shall have proper secondary containment and protection from rainfall.

## 6 TRASH/REFUSE AND DOMESTIC WASTEWATER BPTC MEASURES

Trash and refuse are generated from cannabis cultivation and domestic-related activities. There are three residences located on site. There are 3-4 seasonal employees who work on the site and one full time resident who acts as the cultivation operator/manager.

### 6.1 INVENTORY OF REFUSE SOURCES ON SITE

Table 11 Inventory of Refuse Sources on site.

Refuse Source	Type	Storage Location	Disposal Process
Agricultural activities	Agricultural waste	Secure Waste Area	Bagged and delivered by residents to transfer station weekly or composted in designated waste areas.
Residential	Food waste/domestic waste	Residences, Secure Waste Area	Bagged and delivered by residents to transfer station weekly or composted in designated waste areas.

↑ Refuse to be brought to transfer station is stored in in a secure trailer.

### 6.2 INVENTORY OF WASTEWATER SOURCES ON SITE

Table 12 Inventory of Wastewater Sources on site

Wastewater Source	Treatment Type	Treatment System Location	Additional Notes
Residential	Septic	Residence	Currently not permitted, Owner needs to begin process to permit the existing septic system.

## 7 WINTERIZATION BPTC MEASURES

All applicable erosion control and sediment prevention measures shall be implemented prior to the beginning of the winter period, November 15. The winter period lasts from November 15 to April 1. All soil stockpiles and spoils must either be properly disposed of or fully contained and weatherproofed during this period. Soil left in pots or beds shall either be covered with tarp or seeded with cover crop. Water bars shall be inspected and restored as needed. Any seasonal roads shall be blocked off during this period. No heavy equipment will be used during the winter period. Hydroseed any exposed earth areas with native plant seed to revegetate and stabilize those areas. All culverts shall be inspected and cleared of debris as needed.

## 8 SUMMARY OF CORRECTIVE ACTIONS

Table 13 is a summary of Corrective Actions and BPTC measures that are either underway or yet to be implemented. These measures must be completed prior to the start of the winter period, November 15.

Table 13 Table of Corrective Actions

Map ID	Measure Directive
CV-1	Install 36" culvert with rock armoring in line with native streambed.
CV-2	Replace culvert.
CV-3	Replace culvert.
CV-4	Replace culvert, inboard ditch to hydrologically disconnect roads upslope and downslope.
CV-5	Install 18" CMP culvert.
CV-6	Install rock armoring at outlet of CV-6 to prevent further erosion.
CV-7	Install 30" culvert with rock armoring in line with native streambed.
Cultivation Areas 2 & 3	Hydroseed cut banks above cultivation areas.
WB-1	Install water bar.
WB-2	Install water bar.
Generators	Place generators in secondary containment structures.
N/A	Create designated fuel storage area with secondary containment.
N/A	Create designated agricultural chemical and pesticide storage area with secondary containment.
All Cultivation Areas	Use cover crop or tarping to cover cultivation beds during winter period.
Residence	Agricultural chemicals should be moved to a fully enclosed location with adequate secondary containment and separated from petroleum products
Residence	Petroleum products should be moved to a fully enclosed location with adequate secondary containment and separated from agricultural chemicals
Generators	All generators shall have proper secondary containment and protection from rainfall
All Water Storage Tanks	Fix any leaks in plumbing leading to and from the water storage tanks

## List of Attachments

Attachment A: Site Map

Attachment B: Project Photographs

Attachment C: Best Practicable Treatments and Controls

# Attachment

# A



Site Map





# Attachment B



Project Photos

# Project Photos

For Site Management Plan  
State Water Resources Control Board

APN 210-072-009

Prepared for:  
Kurt Moffitt  
Cali's Finest Gardens, LLC  
Permit No. 12468  
707-502-6853

Prepared by:  
Jackson Ingram, EIT  
Job No. 18052.1  
707-633-8321



MOTHER EARTH  
ENGINEERING

445 I Street

Arcata, CA 95521 - (707)-633-8321

WB-1



Photo #: 1, TS

Date: February 26, 2020

Description: Road section leading to well, add water bar.

WB-2

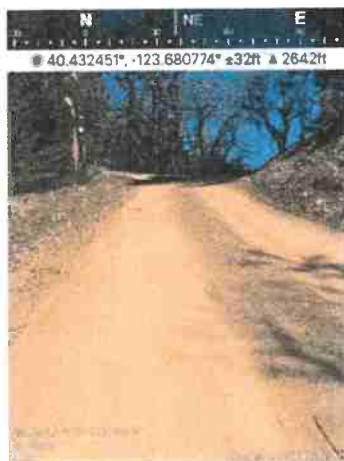

Photo #: 2, TS

Date: February 26, 2020

Description: Road section between Rocked Ford RF-1 and turnoff for irrigation pond, add water bar.

RF-1

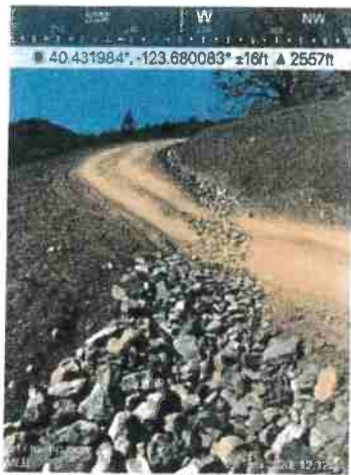

Photo #: 3, TS

Date: February 26, 2020

Description: Drainage Relief ford, RF-1.

Cultivation Areas



Photo #: 4, TS

Date: February 26, 2020

Description: Disturbed areas around cultivation areas sufficiently wood chipped.



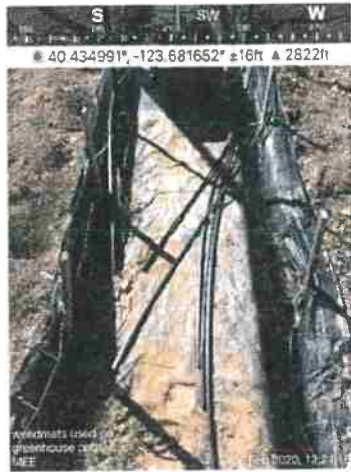

Photo #: 5, TS  
Date: February 26, 2020  
Description: Weed mat used throughout all greenhouse walkways.



Photo #: 6, TS  
Date: February 26, 2020  
Description: Drip irrigation used throughout each greenhouse.



Photo #: 7, TS  
Date: February 26, 2020  
Description: All cultivation areas need to have cover crop or tarps pulled over beds for winter period.



Photo #: 8, TS

Date: February 26, 2020

Description: All soil piles are sufficiently tarped for winter period.

### Cultivation Areas 2 & 3

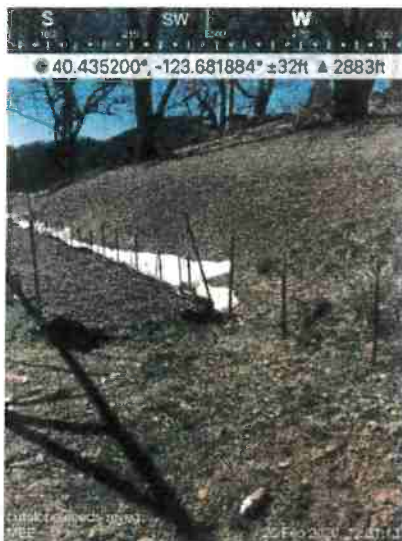

Photo #: 9, TS

Date: February 26, 2020

Description: Cut slope for Cultivation Areas 2 & 3 needs to be hydroseeded and revegetated.

## Water Storage Array

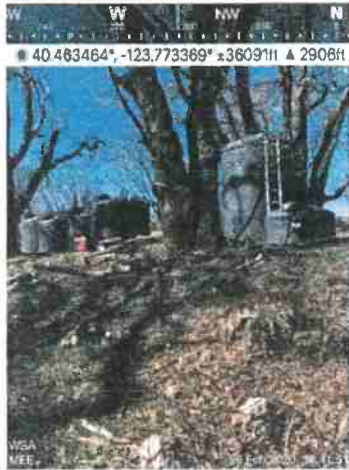

Photo #: 10, TS

Date: February 26, 2020

Description: Water storage tank array.

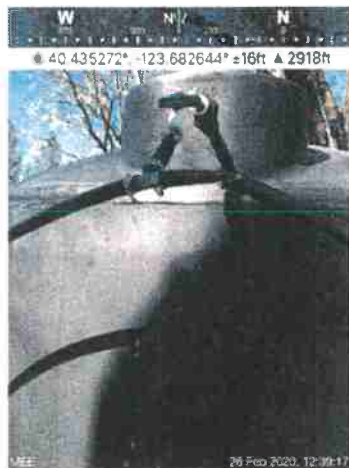

Photo #: 11, TS

Date: February 26, 2020

Description: Water storage tank array leaks.

### Hazardous Material Storage



Photo #: 12, TS

Date: February 26, 2020

Description: No designated fuel storage area or secondary containment.

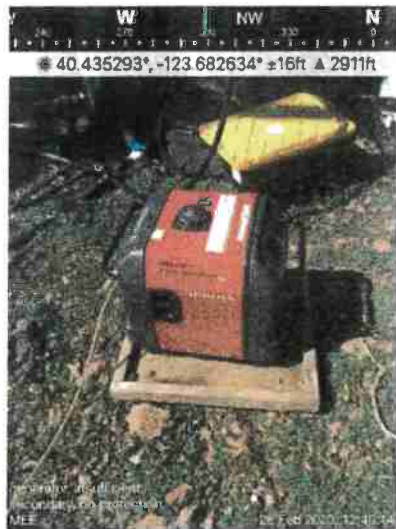

Photo #: 13, TS

Date: February 26, 2020

Description: Generator without proper storage unit or secondary containment.



Photo #: 14, TS  
Date: February 26, 2020  
Description: Generator without proper storage unit or secondary containment.



Photo #: 15, TS  
Date: February 26, 2020  
Description: Agricultural chemicals without proper storage unit or secondary containment.



CV-1



Photo #: 16, TS  
Date: February 26, 2020  
Description: CV-1 inlet.

CV-2

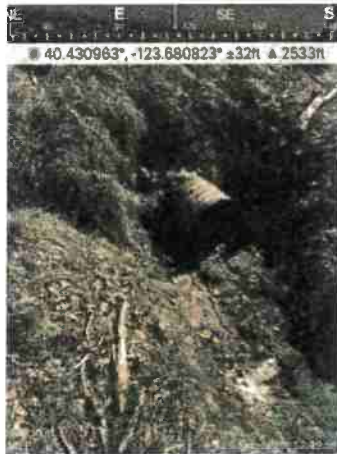

Photo #: 17, TS  
Date: February 26, 2020  
Description: Inlet of CV-2 showing corrosion and erosion.

CV-3



Photo #: 18, TS

Date: February 26, 2020

Description: CV-3 inlet showing corrosion.

CV-4



Photo #: 19, TS

Date: February 26, 2020

Description: CV-4 inlet showing undercutting.

CV-5



Photo #: 20, TS

Date: February 26, 2020

Description: Downstream of CV-5.

CV-6



Photo #: 21, TS

Date: February 26, 2020

Description: CV-6 outlet showing severe erosion.

CV-7



Photo #: 22, TS

Date: February 26, 2020

Description: Upstream location of proposed CV-7, watercourse that currently flows through CV-6.



# Best Practicable Treatments & Controls

Attachment  
C





## Best Practicable Treatments & Controls (BPTCs)

- A) Year Round BPTCs
- B) Conditional BPTCs
- C) BPTC Schedule & Conditional BPTCs
- D) Daily Water Diversion Log
- E) Daily Water Usage Log
- C) Water Delivery Log
- D) Land Disturbance Weather Log
- E) Road and Drainage Feature Maintenance  
Log
- F) Winterization Checklist
- G) Erosion Control Checklist
- H) Soil Disposal and Management Checklist
- I) Erosion and Sediment Control BMPs

## Year-Round BPTCs

In order to maintain compliance with the State Water Board General Order the following conditions shall be met all throughout the year.

Cannabis cultivators shall comply with the minimum riparian setback below for all land disturbance, cannabis cultivation, facilities (material/vehicle/equipment storage, pump locations, portable toilet, water storage), and equipment maintenance/usage:

**Class I watercourses** - Stream that flows 9 months or more of the year, fish present or includes a habitat to sustain fish migration and spawning, lakes, ponds and springs. **Maintain a 150 foot setback.**

**Class II watercourses** - Intermittent watercourse that runs 3 to 9 months a year, provides habitat to non-fish aquatic species. **Maintain a 100-foot setback.**

**Class III watercourses** - Ephemeral watercourse that runs 3 months or less a year, does not provide habitat for riparian vegetation or aquatic species. **Maintain a 50-foot setback.**

**Maintain a complete spill kit on site.** Use spill kit and properly dispose of any spilled agricultural chemicals, petroleum products, or any other hazardous chemicals. Properly dispose all wastes off-site. **All Agricultural products and fuel products require separate storage areas with secondary containment.** Hazardous materials shall only be used by their label usage. No unpermitted pesticides or chemicals are allowed on site. No agricultural products shall be used in the 48 hours before a forecast of 0.25 inches or more with a 50% or greater chance.

**Temporary sediment controls** (seeding and strawing, straw wattles, hay bales, silt fences, etc.) shall be installed within **7 days of any land disturbance activities.** Only native seed and plants shall be used for revegetating disturbed areas.

**Road approaches to water crossings should be rocked if not paved.** The steeper the road the higher quality of surfacing. Winter roads shall be surfaced. Asphalt grindings not allowed for surfacing.

**All applicable permits shall be obtained before working around surface water or wetlands.** Habitat in and immediately around streams cannot be disturbed without the correct permits. These may include CWA 401/404 permits, Regional Water Board WDRs, and CDFW 1600.

Soil, construction, and waste materials should be stored in an area that is stable, contained, and outside of the riparian setbacks.

**Cultivator shall inspect their water distribution system regularly** and immediately repair any leaks.

No domestic wastewater shall be disposed without meeting applicable local and regional regulations. Septic systems must be permitted. Porta-Potties should be sited on stable flat ground and maintained regularly.

**Surface water diversions for cannabis cultivation shall be recorded daily.** Additionally, the water usage for cannabis cultivation shall be recorded daily. Surface water shall not be diverted from April 1<sup>st</sup> to October 31<sup>st</sup>. Surface water diversions must allow 50% of the streamflow to bypass the point of diversion. Surface water diversions are not permitted unless the flow of the watercourse diverted from meets the designated Numeric Flow Requirement. Groundwater may be subject to forbearance, if State Water Board decides so.

For each water delivery make sure to obtain a receipt and information needed to fill out the Water Delivery Log.

Before any land disturbance activity is initiated the conditions on the Land Disturbance Weather Log must be met and it must be filled out through the duration of activities.

Prior to the rainy season and whenever there are large storm events the Road and Drainage Maintenance log shall be filled in. Prior to November 15<sup>th</sup> the Winterization Checklist shall be completed.

**Mother Earth Engineering**  
 Best Practical Treatments & Controls (BPTCs)

BPTCs Schedule												
Monitoring Element	Jan	Feb	Mar	Apr	May	Jun	Jul	Aug	Sep	Oct	Nov	Dec
Water Usage Log	X	X	X	X	X	X	X	X	X	X	X	X
Road and Drainage Maintenance Log	X	X	X	X					X	X	X	X
Winterization Checklist										X	X	
Surface Water Diversion Forbearance				X	X	X	X	X	X	X		

Conditional BPTCs	
If	Then
You plan to do any land disturbance work (grading, clearing, terracing, roadbuilding, culvert installation, etc.)	Make sure you are in possession of all necessary permits (CDFW LSAA, County Grading Permit, etc.). Maintain the Land Disturbance Weather Log, Erosion Control Checklist, and Soil Disposal and Management Checklist. Install erosion and sediment controls within 7 days of the completion of the project. If the project is an emergency project in the winter period (Nov 15 <sup>th</sup> to April 1 <sup>st</sup> ) the Regional Water Board and CDFW must be notified .
A storm produces 0.5 inches of rain within 24 hours or a storm produces 1 inch of rain over 7 days	Fill out the Road Drainage Feature Maintenance Log.
A 48 hours prior rainfall forecast predicts 0.25 inches of rain with 50% chance or greater	No agricultural chemicals/products can be applied.
Your diversion is a surface water diversion	Maintain Water Diversion Log as well as Water Usage Log.
There is exposed ground on your property	Erosion controls must be applied under the guidance of the Erosion Control Checklist .













## Road and Drainage Feature Maintenance Log

Road surfaces and drainage features (culverts, drop inlets, trash racks) shall be closely inspected before the rainy season and after large storm events. Record the dates of inspection and mark down any maintenance work that was completed. Perform inspection and maintenance when any of the following occur:

- Prior to the start of the rainy season
- A storm produces 0.5 inches of rain within 24 hours
- A storm produces 1 inch of rain over 7 days

Examples of road and drainage feature maintenance:

- Wood or debris blocking entrance of ditch relief culvert or stream crossing culvert
- Sediment blocking rolling dip outlet removed and disposed of
- Rocking road where it is necessary

Any sediment or debris removed should be stabilized on a flat area away from surface water or stormwater flow.

Date	Pre-rainy season check or storm event	Maintenance Notes





## Winterization Checklist

The winter season as defined by the State Water Board begins November 15th and ends April 1. Before the winter season begins the cultivator must go through this and the associated checklist and make sure the property that enrolled is winterized. The two associated checklists are the Erosion Control Checklist and the Soil Disposal and Management Checklist. Each time the winterization is completed sign and date below.

By November 15th complete the following:

- Complete the Erosion Control Checklist
- Complete the Soil Disposal and Management Checklist
- Block off seasonal roadways
- Refrain from using any heavy equipment during the winter season unless authorized
- Install linear sediment controls (silt fences, wattles) on the face of exposed slopes at the following spacing:
  - Slopes 0%-25% at 20 feet maximum apart
  - Slopes 25%-50% at 15 feet maximum apart
  - Slopes 50% and greater at 10 feet maximum apart
- Install linear sediment controls at the toe and break of any exposed slopes
- Complete the Drainage Feature Maintenance Log prior to the start of the rainy season
- Stabilize all disturbed areas and construction entrances and exits
- Stabilize all stockpiles using Stockpile Management BMPs (included with this document)
- All exposed or bare ground (cultivation area, access pathways) shall have erosion repair and control measures in place
- Any applicable checklist items that were not completed by November 15th should be reported on this form as well as a schedule for completion.

Date	Notes	Signature
<i>Ex.</i> 11/05/18	<i>ex: Waddles installed a upper cultivation area, perimeter of cultivation area seeded and mulched, all other checklists complete</i>	<i>DB</i>



**Mother Earth Engineering**  
**Best Practical Treatments & Controls (BPTCs)**

## Erosion Control Checklist

The Erosion Control Checklist should be completed when any of the following occur:

- Within seven days of completing any land disturbance activities (grading, terracing, etc)
- When any earthwork using heavy equipment occurs
- Prior to the start of the winter period (Nov 15th)

Each time the Erosion Control Checklist is completed sign and date this checklist.

Complete the following measures if applicable:

- Disturbed areas and/or stockpiles should be controlled by one or a combination of the following methods
  - Seeded and mulched
  - Stockpile Management BMPs
  - Hydroseed
  - Rock slope protection
  - Replanted
  
- The lower gradient perimeter of disturbed areas should be controlled by one or a combination of the following methods
  - Gravel bag berms
  - Silt fences
  - Fiber rolls
  - Sediment settling basins
  - Straw bale barriers
  
- Complete the Soil Disposal and Management Checklist
- Block off seasonal roadway
- Refrain from using any heavy equipment during the winter season unless authorized
- Install linear sediment controls (silt fences, wattles) on the face of exposed slopes at the following spacing:
  - Slopes 0%-25% at 20 feet maximum apart
  - Slopes 25%-50% at 15 feet maximum apart
  - Slopes 50% and greater at 10 feet maximum apart
- Install linear sediment controls at the toe and break of any exposed slopes
- Complete the Drainage Feature Maintenance Log prior to the start of the rainy season
- Stabilize all disturbed areas and construction entrances and exits
- Stabilize all stockpiles using Stockpile Management BMPs (included with this document)
- All exposed or bare ground (cultivation area, access pathways) shall have erosion repair and control measures in place

Date	Notes	Signature
<i>Ex.</i> 11/05/18	<i>ex: Wattles installed a upper cultivation area, perimeter of cultivation area seeded and mulched, all other checklists complete</i>	<i>DB</i>



**Mother Earth Engineering**  
 Best Practical Treatments & Controls (BPTCs)

# Soil Disposal and Management Checklist

The Soil Disposal and Management Checklist should be completed when any of the following occur:

- Whenever soil, growth medium, or construction materials are to be stored on site.
- Prior to the start of the winter period (Nov 15th)

Each time the Soil Disposal and Management Checklist is completed sign and date this checklist.

Complete the following measures if applicable:

- Ensure that all soil, growth medium, and construction materials are stored in a stable, contained manner outside of the riparian setbacks.
- Large organic materials (woody debris, root balls) should be stored separate from soil stockpiles. These materials should be properly disposed of (landfill, burning, composted).
- Sediment control devices (silt fences, straw waddles, strawbales) and tarps should be used to protect soil stockpiles from erosion.
- Alternatively, the stockpiles can be vegetated to prevent erosion
  - Revegetate using a mix of native plant species and seed.
  - Cover with straw at a rate of two tons per acre
  - Apply non-synthetic netting or similar erosion control fabric (jute) on slopes greater than 2:1
- Any soil that is not stored for reuse or vegetated shall be disposed of at an appropriate green waste facility.

<i>Date</i>	<i>Notes</i>	<i>Signature</i>
<i>Ex.</i> 11/05/18	<i>ex: Leftover growth medium has been tarped and surrounded by straw bales on the flat by the cultivation area.</i>	<i>DB</i>





**Mother Earth Engineering**  
Best Practical Treatments & Controls (BPTCs)

# Erosion and Sediment Control BMPs

# Straw Mulch

SS-6

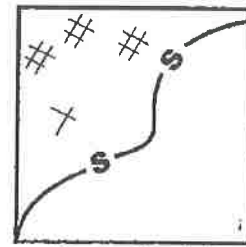
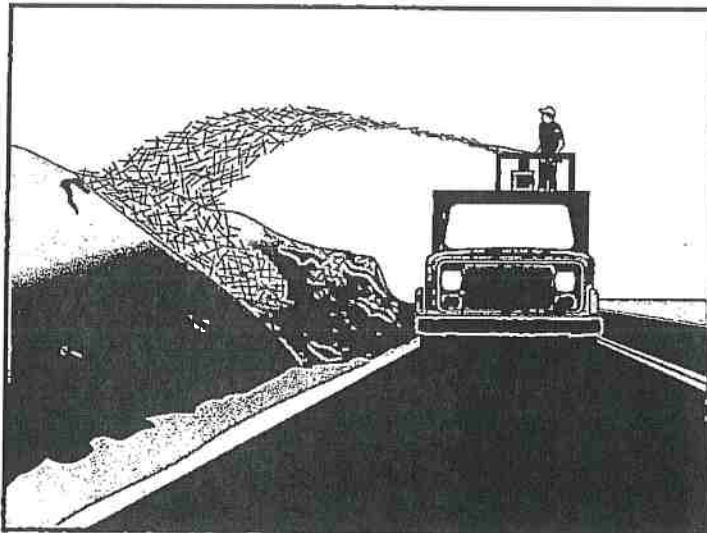

Standard Symbol

### BMP Objectives

- Soil Stabilization
- Sediment Control
- Tracking Control
- Wind Erosion Control
- Non-Storm Water Management
- Materials and Waste Management

**Definition and Purpose** Straw mulch consists of placing a uniform layer of straw and incorporating it into the soil with a studded roller or anchoring it with a stabilizing emulsion. This is one of five temporary soil stabilization alternatives to consider.

### Appropriate Applications

- Straw mulch is typically used for soil stabilization as a temporary surface cover on disturbed areas until soils can be prepared for revegetation and permanent vegetation is established.
- Also typically used in combination with temporary and/or permanent seeding strategies to enhance plant establishment.

### Limitations

- Availability of erosion control contractors and straw may be limited prior to the rainy season due to high demand.
- There is a potential for introduction of weed-seed and unwanted plant material.
- When straw blowers are used to apply straw mulch, the treatment areas must be within 45 m (150 ft) of a road or surface capable of supporting trucks.
- Straw mulch applied by hand is more time intensive and potentially costly.
- May have to be removed prior to permanent seeding or soil stabilization.
- “Punching” of straw does not work in sandy soils.



## Standards and Specifications

- Straw shall be derived from wheat, rice, or barley.
- All materials shall conform to Standard Specifications Sections 20-2.06, 20-2.07 and 20-2.11.
- A tackifier is the preferred method for anchoring straw mulch to the soil on slopes.
- Crimping, punch roller-type rollers, or track-walking may also be used to incorporate straw mulch into the soil on slopes. Track walking shall only be used where other methods are impractical.
- Avoid placing straw onto the traveled way, sidewalks, lined drainage channels, sound walls, and existing vegetation.
- Straw mulch with tackifier shall not be applied during or immediately before rainfall.

## Application Procedures

- Apply loose straw at a minimum rate of 3,570 kg/ha (4,000 lb/ac), or as indicated in the project's special provisions, either by machine or by hand distribution.
- If stabilizing emulsion will be used to anchor the straw mulch in lieu of incorporation, roughen embankment or fill areas by rolling with a crimping or punching-type roller or by track walking before placing the straw mulch. Track walking should only be used where rolling is impractical.
- The straw mulch must be evenly distributed on the soil surface.
- Anchor the mulch in place by using a tackifier or by "punching" it into the soil mechanically (incorporating).
- A tackifier acts to glue the straw fibers together and to the soil surface. The tackifier shall be selected based on longevity and ability to hold the fibers in place.
- A tackifier is typically applied at a rate of 140 kg/ha (125 lb/ac). In windy conditions, the rates are typically 200 kg/ha (178 lb/ac).
- Methods for holding the straw mulch in place depend upon the slope steepness, accessibility, soil conditions and longevity. If the selected method is incorporation of straw mulch into the soil, then do as follows:
  - Applying and incorporating straw shall follow the requirements in Standard Specifications Section 20-3.03.
  - On small areas, a spade or shovel can be used.

- On slopes with soils, which are stable enough and of sufficient gradient to safely support construction equipment without contributing to compaction and instability problems, straw can be "punched" into the ground using a knife-blade roller or a straight bladed coultter, known commercially as a "crimper."
- On small areas and/or steep slopes, straw can also be held in place using plastic netting or jute. The netting shall be held in place using 11 gauge wire staples, geotextile pins or wooden stakes. Refer to BMP SS-7, "Geotextiles, Plastic Covers and Erosion Control Blankets/Mats."

## Maintenance and Inspections

- The key consideration in Maintenance and Inspection is that the straw needs to last long enough to achieve erosion control objectives.
- Maintain an unbroken, temporary mulched ground cover while DSAs are non-active. Repair any damaged ground cover and re-mulch exposed areas.
- Reapplication of straw mulch and tackifier may be required by the Resident Engineer (RE) to maintain effective soil stabilization over disturbed areas and slopes.
- After any rainfall event, the Contractor is responsible for maintaining all slopes to prevent erosion.

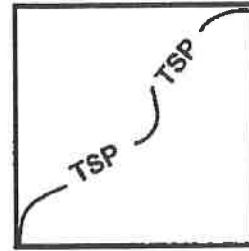
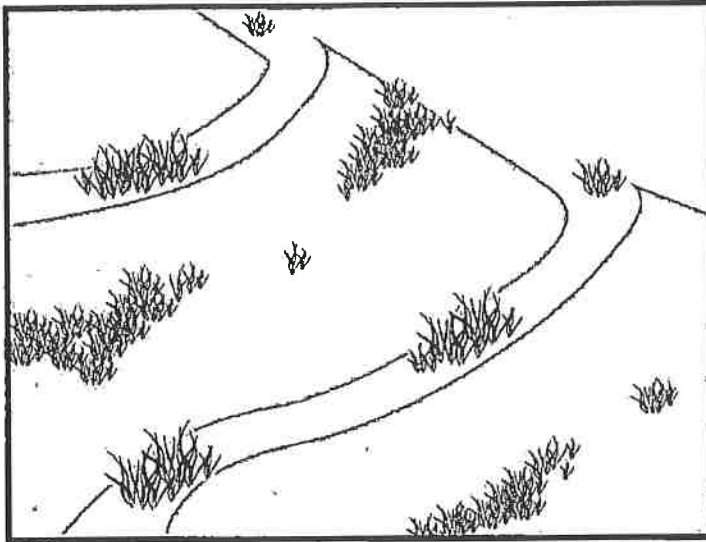

Standard Symbol

**BMP Objectives**

- Soil Stabilization
- Sediment Control
- Tracking Control
- Wind Erosion Control
- Non-Storm Water Management
- Materials and Waste Management

**Definition and Purpose** Hydroseeding typically consists of applying a mixture of wood fiber, seed, fertilizer, and stabilizing emulsion with hydro-mulch equipment, which temporarily protects exposed soils from erosion by water and wind. This is one of five temporary soil stabilization alternatives to consider.

■ **Appropriate Applications** Hydroseeding is applied on disturbed soil areas requiring temporary protection until permanent vegetation is established or disturbed soil areas that **Limitations** must be re-disturbed following an extended period of inactivity.

season to ensure adequate vegetation establishment and erosion control. Otherwise, hydroseeding must be used in conjunction with a soil binder or mulching (i.e., straw mulch), refer to BMP SS-5, Table 1 for options.

- Steep slopes are difficult to protect with temporary seeding.
- Temporary seeding may not be appropriate in dry periods without supplemental irrigation.
- Temporary vegetation may have to be removed before permanent vegetation is applied.
- Temporary vegetation is not appropriate for short-term inactivity.
- Hydroseeding may be used alone only when there is sufficient time in the



**Standards and Specifications** To select appropriate hydroseeding mixtures, an evaluation of site conditions shall be performed with respect to:

- Soil conditions requirements
  - Site topography adjacent areas
  - Season and climate availability
  - Vegetation types permanent vegetation
  - Maintenance
  - Sensitive
  - Water
  - Plans for
- Selection of hydroseeding mixtures shall be approved by the District Landscape Architect and the Construction Storm Water Coordinator.

The following steps shall be followed for implementation:

- Seed mix shall comply with the Standard Specifications Section 20-2.10, and the project's special provisions.
- Hydroseeding can be accomplished using a multiple-step or one-step process; refer to the special provisions for specified process. The multiple-step process ensures maximum direct contact of the seeds to soil. When the onestep process is used to apply the mixture of fiber, seed, etc., the seed rate shall be increased to compensate for all seeds not having direct contact with the soil.
- Prior to application, roughen the slope, fill area, or area to be seeded with the furrows trending along the contours. Rolling with a crimping or punching type roller or track walking is required on all slopes prior to hydroseeding.  
Track walking shall only be used where other methods are impractical.
- Apply a straw mulch to keep seeds in place and to moderate soil moisture and temperature until the seeds germinate and grow, refer to Standard Specifications Sections 20-2.06 and 20-3.03.
- All seeds shall be in conformance with the California State Seed Law of the Department of Agriculture. Each seed bag shall be delivered to the site sealed and clearly marked as to species, purity, percent germination, dealer's guarantee, and dates of test; provide the Resident Engineer (RE) with such documentation. The container shall be labeled to clearly reflect the amount of Pure Live Seed (PLS) contained. All legume seed shall be pellet-inoculated. Inoculant sources shall be species-specific and shall be applied at a rate of 2 kg of inoculant per 100 kg of seed (2-lb inoculant per 100-lb seed), refer to Standard Specifications Section 20-2.10.

- Commercial fertilizer shall conform to the requirements of the California Food and Agricultural Code. Fertilizer shall be pelleted or granular form.
  
- Follow-up applications shall be made as needed to cover weak spots, and to maintain adequate soil protection.
- Avoid over-spray onto the traveled way, sidewalks, lined drainage channels, and existing vegetation.
  
- Maintenance and Inspection ■ All seeded areas shall be inspected for failures and re-seeded, fertilized, and mulched within the planting season, using not less than half the original application rates. Any temporary revegetation efforts that do not provide adequate cover must be reapplied at a scheduled recommended by the Caltrans Landscape Architect or RE.
- After any rainfall event, the Contractor is responsible for maintaining all slopes to prevent erosion.

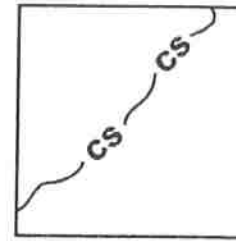

### BMP Objectives

- Soil Stabilization
- Sediment Control
- Tracking Control
- Wind Erosion Control
- Non-Storm Water Management
- Materials and Waste Management

### Standard Symbol

**Definition and Purpose** Stockpile management procedures and practices are designed to reduce or eliminate air and storm water pollution from stockpiles of soil, and paving materials such as portland cement concrete (PCC) rubble, asphalt concrete (AC), asphalt concrete rubble, aggregate base, aggregate subbase or pre-mixed aggregate, asphalt binder (so called "cold mix" asphalt) and pressure treated wood.

**Appropriate Applications** Implemented in all projects that stockpile soil and other materials.

**Limitations** ■ None identified

- Standards and Specifications**
- Protection of stockpiles is a year-round requirement.
  - Locate stockpiles a minimum of 15 m (50 ft) away from concentrated flows of storm water, drainage courses, and inlets.
  - Implement wind erosion control practices as appropriate on all stockpiled material. For specific information see BMP WE-1, "Wind Erosion Control."
  - Stockpiles of contaminated soil shall be managed in accordance with BMP WM-7, "Contaminated Soil Management."
  - Bagged materials should be placed on pallets and under cover.

### ***Protection of Non-Active Stockpiles***

Non-active stockpiles of the identified materials shall be protected further as follows:

- ***Soil stockpiles:***
  - During the rainy seasons, soil stockpiles shall be covered or protected with soil stabilization measures and a temporary perimeter sediment barrier at all times.
  - During the non-rainy season, soil stockpiles shall be covered and protected with a temporary perimeter sediment barrier prior to the onset of precipitation.
- ***Stockpiles of portland cement concrete rubble, asphalt concrete, asphalt concrete rubble, aggregate base, or aggregate subbase:***
  - During the rainy season, the stockpiles shall be covered or protected with a temporary perimeter sediment barrier at all times.
  - During the non-rainy season, the stockpiles shall be covered or protected with a temporary perimeter sediment barrier prior to the onset of precipitation.
- ***Stockpiles of "cold mix":***
  - During the rainy season, cold mix stockpiles shall be placed on and covered with plastic or comparable material at all times.
  - During the non-rainy season, cold mix stockpiles shall be placed on and covered with plastic or comparable material prior to the onset of precipitation.
- ***Stockpiles/Storage of pressure treated wood with copper, chromium, and arsenic or ammonical, copper, zinc, and arsenate:***
  - During the rainy season, treated wood shall be covered with plastic or comparable material at all times.
  - During the non-rainy season, treated wood shall be covered with plastic or comparable material and shall be placed on pallets prior to the onset of precipitation.

### ***Protection of Active Stockpiles***

Active stockpiles of the identified materials shall be protected further as follows:

- All stockpiles shall be covered, stabilized, or protected with a temporary linear sediment barrier prior to the onset of precipitation.

# Stockpile Management

---

**WM-3**

- Stockpiles of "cold mix" shall be placed on and covered with plastic or comparable material prior to the onset of precipitation.

Maintenance and  
directed

■ Repair and/or replace perimeter controls and covers as needed, or as

Inspections

by the RE, to keep them functioning properly. Sediment shall be removed when sediment accumulation reaches one-third (1/3) of the barrier height.



# Gravel Bag Berm

SC-6

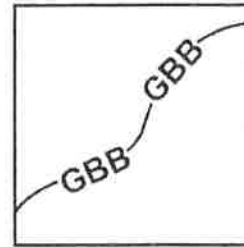
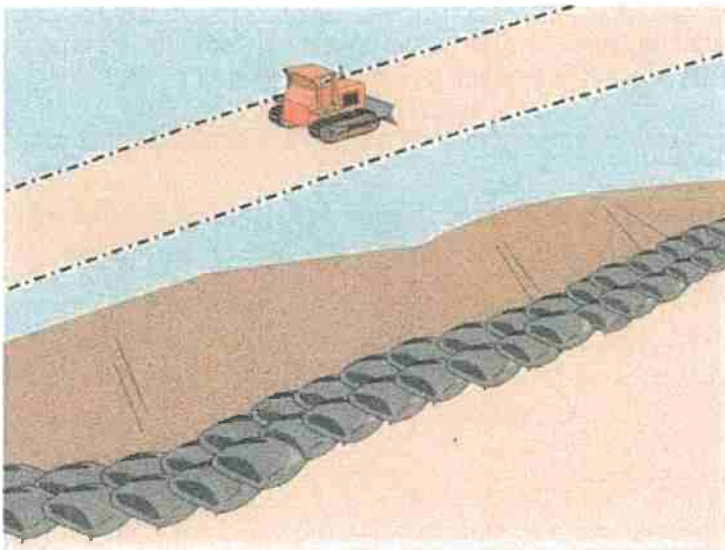

## BMP Objectives

- Soil Stabilization
- Sediment Control
- Tracking Control
- Wind Erosion Control
- Non-Storm Water Management
- Materials and Waste Management

Standard Symbol

## Appropriate Applications Definition and Purpose

A gravel bag berm consists of a single row of gravel bags that are installed end to end to form a barrier across a slope to intercept runoff, reduce its flow velocity, release the runoff as sheet flow and provide some sediment removal. Gravel bags can be used where flows are moderately concentrated, such as ditches, swales, and storm drain inlets (see BMP SC-10, Storm Drain Inlet Protection) to divert and/or detain flows.

- BMP may be implemented on a project-by-project basis with other BMPs when determined necessary and feasible by the RE.
  - Along streams and channels.
  - Below the toe of exposed and erodible slopes.
  - Down slope of exposed soil areas.
  - Around stockpiles.





- Across channels to serve as a barrier for utility trenches or provide a temporary channel crossing for construction equipment, to reduce stream impacts.
  - Parallel to a roadway to keep sediment off paved areas.
  - At the top of slopes to divert roadway runoff away from disturbed slopes.
  - Along the perimeter of a site.
  - To divert or direct flow or create a temporary sediment basin.
  - During construction activities in stream beds when the contributing drainage area is less than 2 ha (5 ac).
  - When extended construction period limits the use of either silt fences or straw bale barriers.
  - When site conditions or construction sequencing require adjustments or relocation of the barrier to meet changing field conditions and needs during construction.
  - At grade breaks of exposed and erodible slopes to shorten slope length and spread runoff as sheet flow.
- Limitations
- Degraded gravel bags may rupture when removed, spilling contents.
  - Installation can be labor intensive.
  - Limited durability for long term projects.
  - When used to detain concentrated flows, maintenance requirements increase.

## Standards and Specifications

### **Materials**

- **Bag Material:** Bags shall be woven polypropylene, polyethylene or polyamide fabric, minimum unit weight 135 g/m<sup>2</sup> (four ounces per square yard), mullen burst strength exceeding 2,070 kPa (300 psi) in conformance with the requirements in ASTM designation D3786, and ultraviolet stability exceeding 70% in conformance with the requirements in ASTM designation D4355.
- **Bag Size:** Each gravel-filled bag shall have a length of 450 mm (18 in), width of 300 mm (12 in), thickness of 75 mm (3 in), and mass of approximately 15 kg (33 lb). Bag dimensions are nominal, and may vary based on locally available materials. Alternative bag sizes shall be submitted to the RE for approval prior to deployment.
- **Fill Material:** Gravel shall be between 10 mm and 20 mm (0.4 and 0.8 inch) in diameter, and shall be clean and free from clay balls, organic matter, and other deleterious materials. The opening of gravel-filled bags shall be between 13 kg and 22 kg (28 and 48 lb) in mass. Fill material is subject to approval by the RE.

### **Installation**

- When used as a linear control for sediment removal:
    - Install along a level contour.
    - Turn ends of gravel bag row up slope to prevent flow around the ends.
    - Generally, gravel bag barriers shall be used in conjunction with temporary soil stabilization controls up slope to provide effective erosion and sediment control.
  - When used for concentrated flows:
    - Stack gravel bags to required height using a pyramid approach.
    - Upper rows of gravel bags shall overlap joints in lower rows.
  - Construct gravel bag barriers with a set-back of at least 1m from the toe of a slope. Where it is determined to be not practicable due to specific site conditions, the gravel bag barrier may be constructed at the toe of the slope, but shall be constructed as far from the toe of the slope as practicable.
  - Requires Certificate of Compliance per Standard Specifications 6-1.07.
- Inspect gravel bag berms before and after each rainfall event, and weekly throughout the rainy season.

## Maintenance and Inspection



# Gravel Bag Berm

---

SC-6

- Reshape or replace gravel bags as needed, or as directed by the RE.
- Repair washouts or other damages as needed, or as directed by the RE.
- Inspect gravel bag berms for sediment accumulations and remove sediments when accumulation reaches one-third of the berm height. Removed sediment shall be incorporated in the project at locations designated by the RE or disposed of outside the highway right-of-way in conformance with the Standard Specifications.
- Remove gravel bag berms when no longer needed. Remove sediment accumulations and clean, re-grade, and stabilize the area.





### BMP Objectives

- Soil Stabilization
- Sediment Control
- Tracking Control
- Wind Erosion Control
- Non-Storm Water Management
- Materials and Waste Management

### Standard Symbol

**Definition and Purpose** A fiber roll consists of wood excelsior, rice or wheat straw, or coconut fibers that is rolled or bound into a tight tubular roll and placed on the toe and face of slopes to intercept runoff, reduce its flow velocity, release the runoff as sheet flow and provide removal of sediment from the runoff. Fiber rolls may also be used for inlet protection and as check dams under certain situations.

# Fiber Rolls

SC-5

## ■ Appropriate Applications

This BMP may be implemented on a project-by-project basis with other

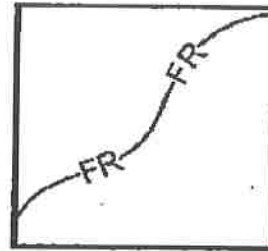

## BMPs

when determined necessary and feasible by the RE.

## ■ slopes

Along the toe, top, face, and at grade breaks of exposed and erodible to shorten slope length and spread runoff as sheet flow.

- Below the toe of exposed and erodible slopes.

## ■ the (refer to

Fiber rolls may be used as check dams in unlined ditches if approved by Resident Engineer (RE) or the District Construction Storm Water Coordinator SC-4 "Check Dams").

## ■ or the Inlet

Fiber rolls may be used for drain inlet protection if approved by the RE District Construction Storm Water Coordinator (refer to SC-10 "Storm Drain Protection").

- Down-slope of exposed soil areas.
- Around temporary stockpiles.
- Along the perimeter of a project.

- Limitations**
- Runoff and erosion may occur if fiber roll is not adequately trenched in.
  - Fiber rolls at the toe of slopes greater than 1:5 may require the use of 500 mm (20" diameter) or installations achieving the same protection (i.e., stacked smaller diameter fiber rolls, etc.).
  - Fiber rolls may be used for drainage inlet protection if they can be properly anchored.
  - Difficult to move once saturated.
  - Fiber rolls could be transported by high flows if not properly staked and trenched in.
  - Fiber rolls have limited sediment capture zone.
  - Do not use fiber rolls on slopes subject to creep, slumping, or landslide.

## Standards and Specifications

### **Fiber Roll Materials**

Fiber rolls shall be either:

- (1) Prefabricated rolls.
- (2) Rolled tubes of erosion control blanket.

### **Assembly of Field Rolled Fiber Roll**

- Roll length of erosion control blanket into a tube of minimum 200 mm (8 in) diameter.
- Bind roll at each end and every 1.2 m (4 ft) along length of roll with jute-type twine.

### **Installation**

- Slope inclination of 1:4 or flatter: fiber rolls shall be placed on slopes 6.0 m apart.
- Slope inclination of 1:4 to 1:2: fiber rolls shall be placed on slopes 4.5 m apart.
- Slope inclination 1:2 or greater: fiber rolls shall be placed on slopes 3.0 m apart.
- Stake fiber rolls into a 50 to 100 mm (2 to 4 in) trench.



- Drive stakes at the end of each fiber roll and spaced 600 mm (2 ft) apart if Type 2 installation is used (refer to Page 4). Otherwise, space stakes 1.2 m (4 ft) maximum on center if installed as shown on Pages 5 and 6.
- Use wood stakes with a nominal classification of 19 by 19 mm (3/4 by 3/4 in), and minimum length of 600 mm (24 in).
- If more than one fiber roll is placed in a row, the rolls shall be overlapped; not abutted.

### **Removal**

- Fiber rolls are typically left in place.
- If fiber rolls are removed, collect and dispose of sediment accumulation, and fill and compact holes, trenches, depressions or any other ground disturbance to blend with adjacent ground.
- Repair or replace split, torn, unraveling, or slumping fiber rolls.
- Inspect fiber rolls when rain is forecast. Perform maintenance as needed or as required by the RE.
- Inspect fiber rolls following rainfall events and a least daily during prolonged rainfall. Perform maintenance as needed or as required by the RE.
- Maintain fiber rolls to provide an adequate sediment holding capacity. Sediment shall be removed when the sediment accumulation reaches three quarters (3/4) of the barrier height. Removed sediment shall be incorporated in the project at locations designated by the RE or disposed of outside the highway right-of-way in conformance with the Standard Specifications.

### **Maintenance and Inspection**

**SC-5**

**Fiber Rolls**

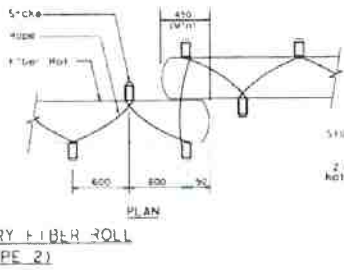
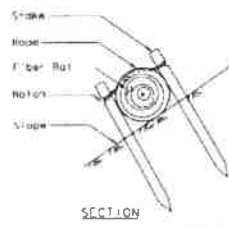
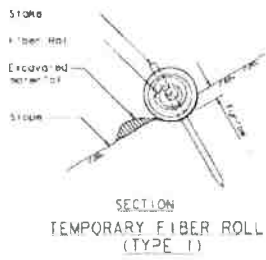

REGISTERED PROFESSIONAL ENGINEER  
STATE OF CALIFORNIA  
No. 10000  
EXPIRES 12/31/03  
C. J. ...

NOTE  
Temporary fiber roll spacing varies depending upon slope inclination.

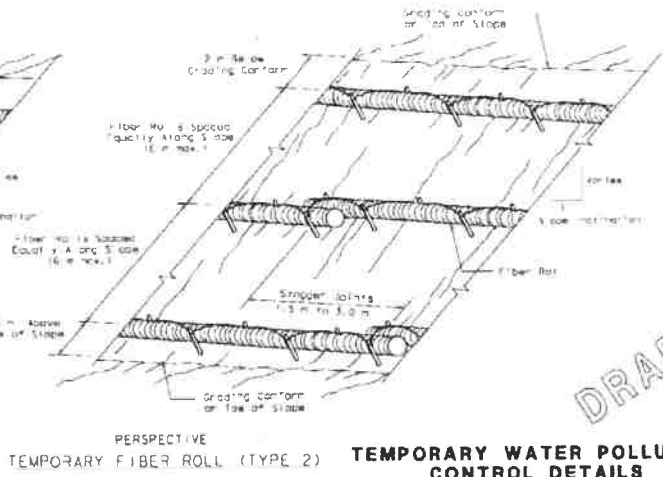
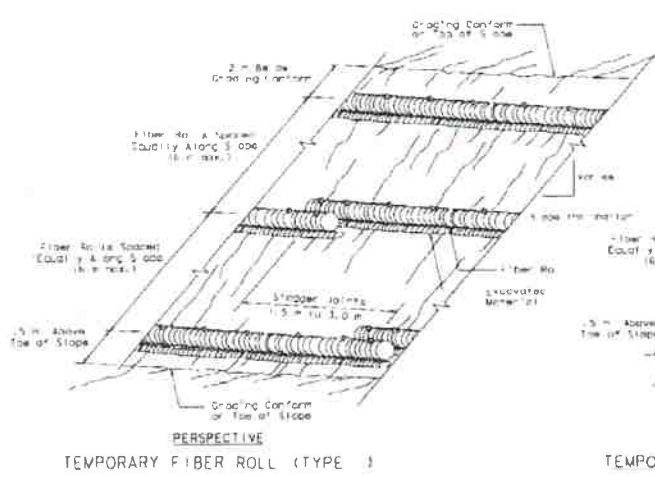

**TEMPORARY WATER POLLUTION CONTROL DETAILS**

DRAFT

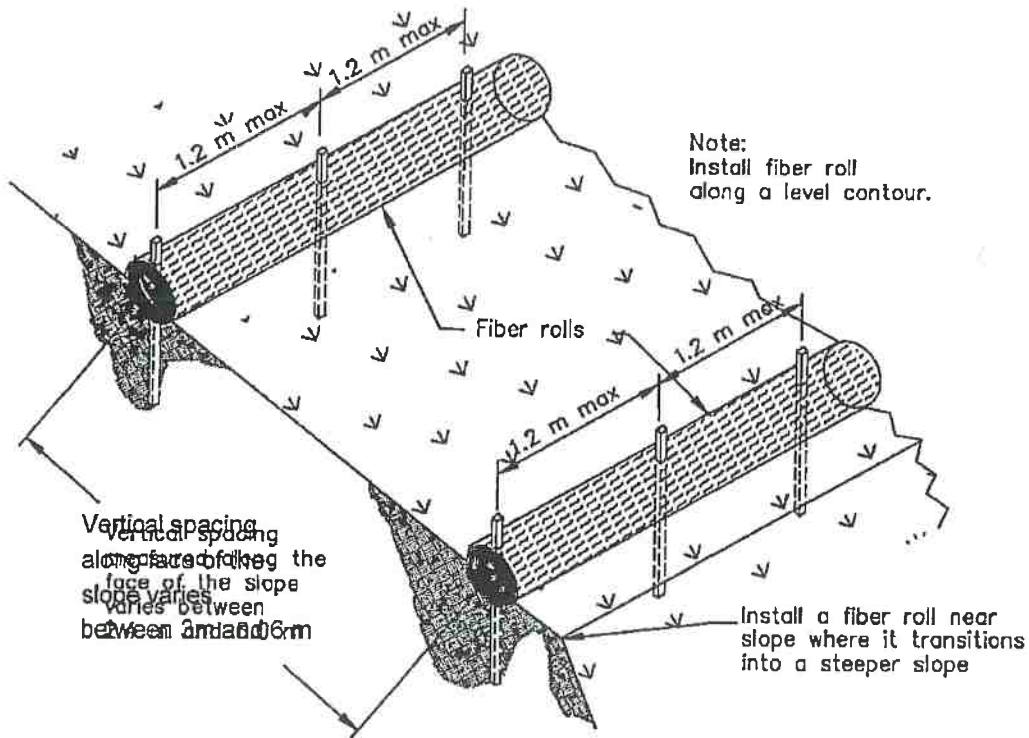

TYPICAL FIBER ROLL INSTALLATION

N.T.S.

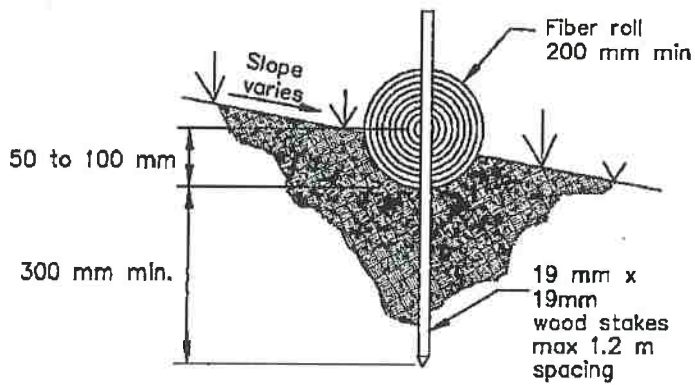

ENTRENCHMENT DETAIL

N.T.S.

N.T.S.

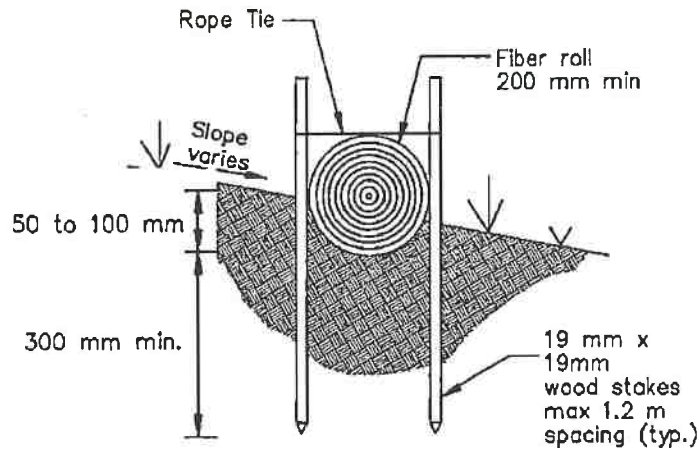
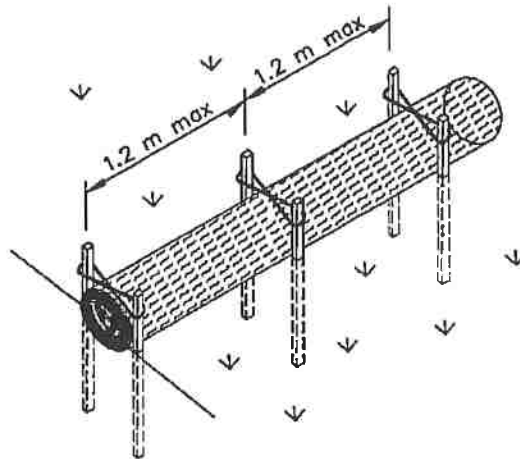

OPTIONAL ENTRENCHMENT DETAIL

# Straw Bale Barrier

SC-9

## Appropriate Applications

■ This BMP may be implemented on a project-by-project basis in addition to other BMPs when determined necessary and feasible by the Resident

Engineer (RE).

- Along the perimeter of a site.
- Along streams and channels.
- Below the toe of exposed and erodible slopes.
- Down slope of exposed soil areas.
- Around stockpiles.
- Across minor swales or ditches with small catchments.

## Definition and Purpose

A straw bale barrier is a temporary linear sediment barrier consisting of straw bales, designed to intercept and slow sediment-laden sheet flow runoff. Straw bale barriers allow sediment to settle from runoff before water leaves the construction site.

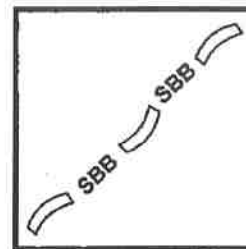
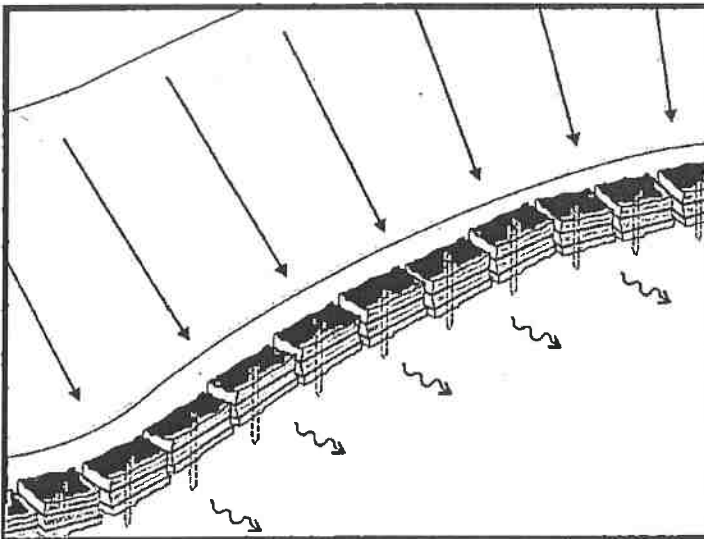

Standard Symbol

### BMP Objectives

- Soil Stabilization
- Sediment Control
- Tracking Control
- Wind Erosion Control
- Non-Storm Water Management
- Materials and Waste Management

- Around above grade type temporary concrete washouts (See BMP WM-8, "Concrete Waste Management").  
Parallel to a roadway to keep sediment off paved areas.

## Limitations

- Installation can be labor intensive.
- Straw bale barriers are maintenance intensive.
- Degraded straw bales may fall apart when removed or left in place for extended periods.
- Can't be used on paved surfaces.
- Not to be used for drain inlet protection.
- Shall not be used in areas of concentrated flow.
- Can be an attractive food source for some animals.
- May introduce undesirable non-native plants to the area.

## Standards and Specifications

### Materials

- **Straw Bale Material:** Straw bale materials shall conform to the provisions in Standard Specifications Section 20-2.06, "Straw."
- **Straw Bale Size:** Each straw bale shall be a minimum of 360 mm (14 in) wide, 450 mm (18 in) in height, 900 mm (36 in) in length and shall have a minimum mass of 23 kg (51 lb.) The straw bale shall be composed entirely of vegetative matter, except for the binding material.



- **Bale Bindings:** Bales shall be bound by either steel wire, nylon or polypropylene string placed horizontally. Jute and cotton binding shall not be used. Baling wire shall be a minimum diameter of 1.57 mm (0.06 inch). Nylon or polypropylene string shall be approximately 2 mm (0.08 inch) in diameter with a breaking strength of 360 N.
- **Stakes:** Wood stakes shall be commercial quality lumber of the size and shape shown on the plans. Each stake shall be free from decay, splits or cracks longer than the thickness of the stake, or other defects that would weaken the stakes and cause the stakes to be structurally unsuitable. Steel bar reinforcement shall be equal to a number four designation or greater. End protection shall be provided for any exposed bar reinforcement.

## ***Installation***

- Limit the drainage area upstream of the barrier to 0.3 ha/100 m (0.25 ac/100ft) or barrier.
- Limit the slope length draining to the straw bale barrier to 30 m (100 ft.)
- Slopes of 2:100 (V:H) (2%) or flatter are preferred. If the slope exceeds 1:10 (V:H) (10%), the length of slope upstream of the barrier must be less than 15 m (50 ft).
- Install straw bale barriers along a level contour, with the last straw bale turned up slope.
- Straw bales must be installed in a trench and tightly abut adjacent bales.

## Maintenance and Inspection

- Construct straw bale barriers with a set-back of at least 1 m (3 ft) from the toe of a slope. Where it is determined to be not practical due to specific site conditions, the straw bale barrier may be constructed at the toe of the slope, but shall be constructed as far from the toe of the slope as practical.
- See pages 4 and 5 of this BMP for installation detail.
- Inspect straw bale barriers before and after each rainfall event, and weekly throughout the rainy season.
- Inspect straw bale barriers for sediment accumulations and remove sediment when depth reaches one-third the barrier height. Removed sediment shall be incorporated in the project at locations designated by the RE or disposed of outside the highway right-of-way in conformance with the Standard Specifications.
- Replace or repair damage bales as needed or as directed by the RE.
- Repair washouts or other damages as needed or as directed by the RE.
- Remove straw bales when no longer needed. Remove sediment accumulation, and clean, re-grade, and stabilize the area.

# Straw Bale Barrier

**SC-9**

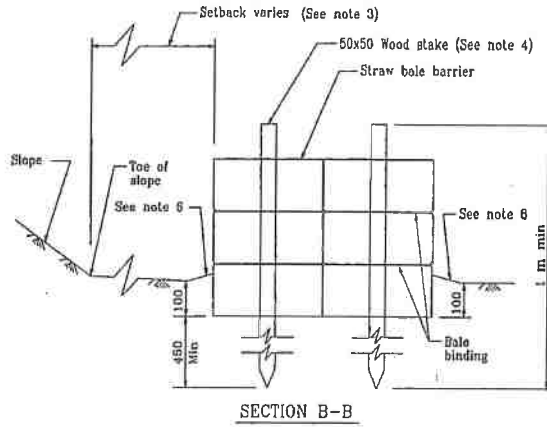

**SECTION B-B**

**LEGEND**

--- DIRECTION OF FLOW

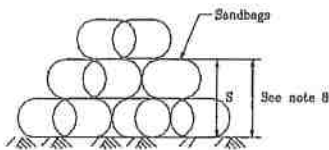

**SANDBAG CROSS-BARRIER**

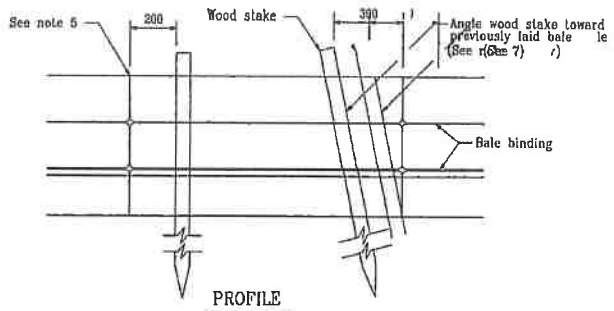

STATE OF CALIFORNIA  
DEPARTMENT OF TRANSPORTATION  
**TEMPORARY LINEAR SEDIMENT BARRIER  
(TYPE STRAW-BALE)**  
NO SCALE  
ALL DIMENSIONS ARE IN  
MILLIMETERS UNLESS OTHERWISE SHOWN

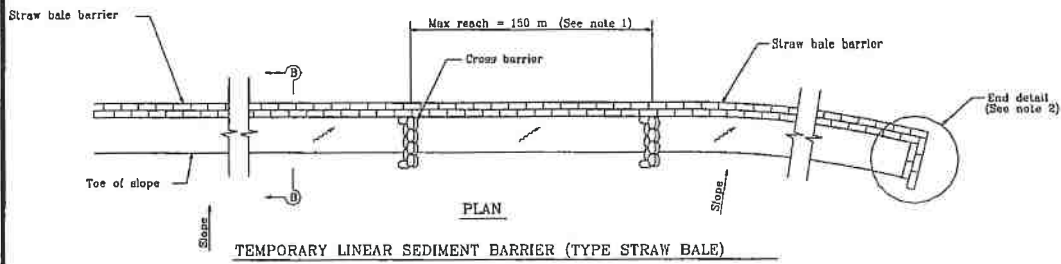

TEMPORARY LINEAR SEDIMENT BARRIER (TYPE STRAW BALE)

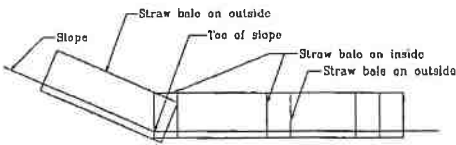

END DETAIL



NOTES

- 1. Construct the length of each reach so that the change in base elevation along the reach does not exceed 1/2 the height of linear barrier. In no case shall the reach length exceed 150 m.
- 2. End of barrier shall be turned up slope.
- 3. Dimension may vary to fit field conditions.

- a. Place
- b. Temp
- c. Cross
- d. End detail

STATE OF CALIFORNIA  
 DEPARTMENT OF TRANSPORTATION  
 TEMPORARY LINEAR SEDIMENT BARRIER  
 (TYPE STRAW BALE)  
 NO SCALE  
 ALL DIMENSIONS ARE IN MILLIMETERS UNLESS OTHERWISE SHOWN

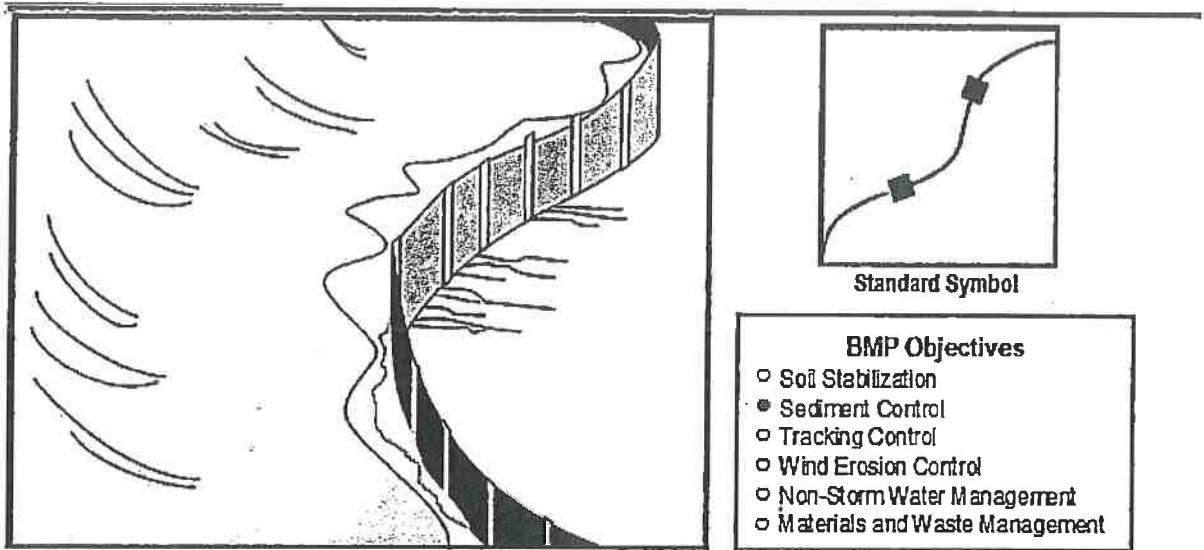

**Definition and Purpose** A silt fence is a temporary linear sediment barrier of permeable fabric designed to intercept and slow the flow of sediment-laden sheet flow runoff. Silt fences allow sediment to settle from runoff before water leaves the construction site.

- Appropriate Applications** Silt fences are placed:
- Below the toe of exposed and erodible slopes.
  - Down-slope of exposed soil areas.
  - Around temporary stockpiles.
  - Along streams and channels.
  - Along the perimeter of a project.

- Limitations**
- Not effective unless trenched and keyed in.
  - Not intended for use as mid-slope protection on slopes greater than 1:4 (V:H).
  - Must be maintained.

- Must be removed and disposed of.
- Don't use below slopes subject to creep, slumping, or landslides.
- Don't use in streams, channels, drain inlets, or anywhere flow is concentrated.
- Don't use silt fences to divert flow.

## Standards and Specifications

### ***Design and Layout***

- The maximum length of slope draining to any point along the silt fence shall be 61 m (200 ft) or less.
- Slope of area draining to silt fence shall be less than 1:1 (V:H).
- Limit to locations suitable for temporary ponding or deposition of sediment.
- Fabric life span generally limited to between five and eight months. Longer periods may require fabric replacement.
- Silt fences shall not be used in concentrated flow areas.
- Lay out in accordance with Pages 5 and 6 of this BMP.
- For slopes steeper than 1:2 (V:H) and that contain a high number of rocks or large dirt clods that tend to dislodge, it may be necessary to install additional protection immediately adjacent to the bottom of the slope, prior to installing silt fence. Additional protection may be a chain link fence or a cable fence.
- For slopes adjacent to water bodies or Environmentally Sensitive Areas (ESAs), additional temporary soil stabilization BMPs shall be used.

### ***Materials***

- Silt fence fabric shall be woven polypropylene with a minimum width of 900 mm (36 inches) and a minimum tensile strength of 0.45-kN. The fabric shall conform to the requirements in ASTM designation D4632 and shall have an integral reinforcement layer. The reinforcement layer shall be a polypropylene, or equivalent, net provided by the manufacturer. The permittivity of the fabric shall be between  $0.1 \text{ sec}^{-1}$  and  $0.15 \text{ sec}^{-1}$  in conformance with the requirements in ASTM designation D4491. Contractor



must submit certificate of compliance in accordance with Standard Specifications Section 6-1.07.

- Wood stakes shall be commercial quality lumber of the size and shape shown on the plans. Each stake shall be free from decay, splits or cracks longer than the thickness of the stake or other defects that would weaken the stakes and cause the stakes to be structurally unsuitable.
- Bar reinforcement may be used, and its size shall be equal to a number four (4) or greater. End protection shall be provided for any exposed bar reinforcement.
- Staples used to fasten the fence fabric to the stakes shall be not less than 45 mm (1.75 inches) long and shall be fabricated from 1.57 mm (0.06 inch) or heavier wire. The wire used to fasten the tops of the stakes together when joining two sections of fence shall be 3.05 mm (0.12 inch) or heavier wire. Galvanizing of the fastening wire is not required.

### ***Installation***

- Generally, silt fences shall be used in conjunction with soil stabilization source controls up slope to provide effective erosion and sediment control.
- Bottom of the silt fence shall be keyed-in a minimum of 150 mm (12 inches).
- Trenches shall not be excavated wider and deeper than necessary for proper installation of the temporary linear sediment barriers.
- Excavation of the trenches shall be performed immediately before installation of the temporary linear sediment barriers.
- Construct silt fences with a set-back of at least 1m (3 ft) from the toe of a slope. Where a silt fence is determined to be not practical due to specific site conditions, the silt fence may be constructed at the toe of the slope, but shall be constructed as far from the toe of the slope as practical.
- Construct the length of each reach so that the change in base elevation along the reach does not exceed 1/3 the height of the barrier; in no case shall the reach exceed 150 meters (490 ft).
- Cross barriers shall be a minimum of 1/3 and a maximum of 1/2 the height of the linear barrier.



North Coast Regional Water Quality Control Board

November 15, 2019

WDID:1\_12CC417947

CALI'S FINEST GARDENS, LLC.
ATTN: KURT MOFFITT
3441 L STREET
EUREKA, CA 95503

Subject: Notice of Applicability - Waste Discharge Requirements Water Quality Order WQ 2019-0001-DWQ

The attached Notice of Applicability provides notice that the requirements of the State Water Board Cannabis Cultivation Policy- Principles and Guidelines for Cannabis Cultivation (Policy), and the General Waste Discharge Requirements and Waiver of Waste Discharge Requirements for Discharges of Waste Associated with Cannabis Cultivation Activities, Order WQ 2019-0001-DWQ (General Order - previously WQ 2017-0023-DWQ, with updates and revisions effective April 16, 2019) are applicable to the site as described below. Based on the information provided, the Discharger self-certifies the cannabis cultivation activities are consistent with the requirements of the State Water Board Policy and General Order.

Please direct all submittals, discharge notifications, and questions regarding compliance and enforcement to the North Coast Regional Water Quality Control Board Cannabis Program at (707) 576-2676 or northcoast.cannabis@waterboards.ca.gov.

Sincerely,

2019.11.15 15:18:54 PST
Kason Grady
Water Boards

Matthias St. John
Executive Officer
North Coast Regional Water Quality Control Board

191115\_1L\_1\_12CC417947\_1B171807CHUM Cali's Finest Gardens LLC\_NOA\_TW

**NOTICE OF APPLICABILITY – WASTE DISCHARGE REQUIREMENTS, WATER QUALITY ORDER WQ 2019-0001-DWQ, CALI'S FINEST GARDENS, LLC., HUMBOLDT COUNTY APN(s) 210-072-009-000**

Cali's Finest Gardens, LLC. (hereafter "Discharger") submitted information through the State Water Resources Control Board's (State Water Board's) online portal on June 25, 2019, for discharges of waste associated with cannabis cultivation related activities. Based on the information provided, the Discharger self-certifies the cannabis cultivation activities are consistent with the requirements of the Policy and General Order. This letter provides notice that the Policy and General Order are applicable to the site as described below. You are hereby assigned waste discharge identification (WDID) number **1\_12CC417947**. The original WDID assigned by the North Coast Regional Water Quality Control Board was 1B171807CHUM.

The Discharger is responsible for all the applicable requirements in the Policy, General Order, and this Notice of Applicability (NOA). This includes making any necessary changes to the enrollment, and the Discharger is the sole person or entity with legal authority to make those changes. The Discharger will be held liable for any noncompliance with the Policy, General Order, and the NOA.

**1. FACILITY AND DISCHARGE DESCRIPTION**

All dischargers enrolled under the North Coast Regional Water Board's Order (R1-2015-0023) or the Central Valley Regional Water Board's Order (R5-2015-0113) as of October 17, 2017, (the adoption date of the General Order) may retain the reduced setbacks applicable under the appropriate Regional Water Board order unless the Executive Officer for the appropriate Regional Board determines that the reduced setbacks applicable under their regional order are not protective of water quality. However, sites that expand their cannabis cultivation area or other cannabis related activities must comply with the riparian setbacks in the General Order.

The information submitted by the Discharger states the disturbed area is equal to or greater than 2,000 square feet and less than 1 acre (43,560 square feet) no portion of the disturbed area is within the setback requirements, no portion of the disturbed area is located on a slope greater than 30 percent, and the cannabis cultivation area is less than or equal to 1 acre.

Based on the information submitted by the Discharger, the cannabis cultivation activities are classified as Tier 1 Low Risk.

**2. SITE-SPECIFIC REQUIREMENTS**

The Policy and General Order are available on the Internet at:

[https://www.waterboards.ca.gov/water\\_issues/programs/cannabis/cannabis\\_water\\_quality.html](https://www.waterboards.ca.gov/water_issues/programs/cannabis/cannabis_water_quality.html)

The Discharger shall ensure that all site operating personnel know, understand, and comply with the requirements contained in the Policy, General Order, this NOA, and the Monitoring and Reporting Program (MRP, Attachment B of the General Order). Note that the General Order contains standard provisions, general requirements, and prohibitions that apply to all cannabis cultivation activities.

The application requires the Discharger to self-certify that all applicable Best Practicable Treatment or Control (BPTC) measures are being implemented, or will be implemented by the onset of the winter period (November 15 - April 1), following the enrollment date. Landowners of the cultivation site in the North Coast Region are required to submit and implement Site Management Plans that describes how BPTC measures are implemented property-wide, including BPTC measures implemented to address discharges from legacy activities (e.g. former timber harvest, road building, mining, etc.) at the site per Provision C.1.a. of the General Order. Dischargers that cannot implement all applicable BPTC measures by the onset of the winter period, following their enrollment date, shall submit to the appropriate Regional Water Board a *Site Management Plan* that includes a time schedule and scope of work for use by the Regional Water Board in developing a compliance schedule as described in Attachment A of the General Order.

The Policy and General Order require that, prior to conducting any work in streams or wetlands, the Discharger obtain water quality certification from the Water Boards and other required permits from other agencies (e.g. a Clean Water Act section 404 permit from the United States Army Corps of Engineers, a Lake and Streambed Alteration Agreement from the California Department of Fish and Wildlife, and other local permits). Enrollment in the General Order requires that the Discharger obtain water quality certification for any such work, but this NOA does not provide the necessary certification. If the Discharger proposes or requires work in streams or wetlands, they must apply for water quality certification separately by filling out and submitting a separate application for that work. The application is available for download at the following Regional Water Board website:

[https://www.waterboards.ca.gov/northcoast/water\\_issues/programs/cannabis/](https://www.waterboards.ca.gov/northcoast/water_issues/programs/cannabis/)

Currently, the direct link to that application is as follows:

[https://www.waterboards.ca.gov/northcoast/water\\_issues/programs/cannabis/pdf/190403/180731\\_031616\\_401\\_WQ2017-0023-Application.pdf](https://www.waterboards.ca.gov/northcoast/water_issues/programs/cannabis/pdf/190403/180731_031616_401_WQ2017-0023-Application.pdf)

Note: Water Quality Certifications require separate application and monitoring fees. A fee calculator and additional information are available at:

[https://www.waterboards.ca.gov/northcoast/water\\_issues/programs/water\\_quality\\_certification/#401\\_calc](https://www.waterboards.ca.gov/northcoast/water_issues/programs/water_quality_certification/#401_calc)

During reasonable hours, the Discharger shall allow the State Water Board or Regional Water Board (collectively Water Boards), California Department of Fish and Wildlife, CAL FIRE, and any other authorized representatives of the Water Boards upon presentation of a badge, employee identification card, or similar credentials, to:



- i. enter premises and facilities where cannabis is cultivated; where water is diverted, stored, or used; where wastes are treated, stored, or disposed; or in which any records are kept;
- i. access and copy, any records required to be kept under the terms and conditions of the Policy and General Order;
- ii. inspect, photograph, and record audio and video, any cannabis cultivation sites, and associated premises, facilities, monitoring equipment or device, practices, or operations regulated or required by the Policy and General Order; and
- iii. sample, monitor, photograph, and record audio and video of site conditions, any discharge, waste material substances, or water quality parameters at any location for the purpose of assuring compliance with the Policy and General Order.

### **3. TECHNICAL REPORT REQUIREMENTS**

The following technical report(s) shall be submitted by the Discharger as described below:

A Site Management Plan, by September 22, 2019, consistent with the requirements of General Order Provision C.1.a., and Attachment A, Section 5. Attachment D of the General Order provides guidance on the contents of the Site Management Plan.

A *Site Closure Report* must be submitted 90 days prior to permanently ending cannabis cultivation activities and seeking to rescind coverage under the General Order. The *Site Closure Report* must be consistent with the requirements of General Order Provision C.1.e., and Attachment A, Section 5. Attachment D of the General Order provides guidance on the contents of the *Site Closure Report*.

### **4. MONITORING AND REPORTING PROGRAM**

The Discharger shall comply with all provisions of the Monitoring and Reporting Program (MRP), which appears as Attachment B to the General Order. The Discharger shall also comply with all provisions of the *North Coast Regional Supplement to Annual Monitoring and Reporting Requirements for Statewide Cannabis General Order WQ 2017-0023-DWQ* (Regional Supplement), which independently appears as Investigative Order No. R1-2019-0023, issued by the Regional Water Board Executive Officer on March 22, 2019. Annual reports for both sets of requirements shall be submitted to the Regional Water Board in a combined report by March 1 following the year being monitored through the online portal (<https://public2.waterboards.ca.gov/cgo>). The Discharger shall not implement any changes to the MRP or to the Regional Supplement unless and until a revised MRP or Regional Supplement is issued by the Regional Water Board Executive Officer or the State Water Board Division of Water Quality Deputy Director, or the State Water Board Chief Deputy Director.

A copy of Attachment B to the General Order can be obtained online at the following location, or by contacting staff at the phone number and email address listed below.  
[https://www.waterboards.ca.gov/board/decisions/adopted\\_orders/water\\_quality/2019/wq2019\\_0001\\_dwq.pdf#page=32](https://www.waterboards.ca.gov/board/decisions/adopted_orders/water_quality/2019/wq2019_0001_dwq.pdf#page=32).

A copy of the Regional Supplement can be obtained online at the following location, or by contacting staff at the phone number and email address listed below.

[https://www.waterboards.ca.gov/northcoast/board\\_decisions/adopted\\_orders/pdf/2019/19\\_0023\\_Regional%20Supplement%2013267%20Order.pdf](https://www.waterboards.ca.gov/northcoast/board_decisions/adopted_orders/pdf/2019/19_0023_Regional%20Supplement%2013267%20Order.pdf).

#### **5. ANNUAL FEE**

According to the information submitted, the discharge is classified as Tier 1 Low Risk. The 2018-2019 annual fee for that tier and risk level was set at \$600, but please note that the Fee Schedule is updated annually and future fees may be invoiced at different rates. Invoices are sent by the State Water Board at the beginning of each calendar year (generally in February). Do not submit payments without receiving an invoice. If you have questions or concerns about your fees please contact the Fee Branch at [FeeBranch@waterboards.ca.gov](mailto:FeeBranch@waterboards.ca.gov) or (916) 341-5247. The fee is due and payable on an annual basis until coverage under this General Order is formally rescinded. To rescind coverage, the Discharger must submit a Request for Termination in writing through the online portal (available at: <https://public2.waterboards.ca.gov/cgo>), including a Site Closure Report at least 90 days prior to termination of activities and include a final MRP report.

#### **6. TERMINATION OF COVERAGE UNDER THE GENERAL ORDER & REGIONAL WATER BOARD CONTACT INFORMATION**

Enrollees that propose to terminate coverage under the General Order must submit a Request for Termination in writing through the online portal (<https://public2.waterboards.ca.gov/cgo>). The Request for Termination consists of a formal statement regarding the reason for requesting termination (i.e. cultivation is no longer occurring, the property is being sold, etc.), documentation that the site is in compliance with the General Order, including dated photographs and a written discussion. If the site is not meeting the requirements of the General Order, then the enrollment cannot be terminated. Regional Water Board staff will review the Request for Termination for completeness before determining if a property inspection, enrollment termination, or a request for additional information is appropriate.

If the Discharger cannot comply with the General Order, or will be unable to implement an applicable BPTC measure contained in Attachment A by the onset of the winter period each year, the Discharger shall notify the North Coast Regional Cannabis Unit staff at (707) 576-2676 or [northcoast.cannabis@waterboards.ca.gov](mailto:northcoast.cannabis@waterboards.ca.gov) so that a site-specific compliance schedule can be developed.

Cc: Kevin Porzio, State Water Resources Control Board,  
[dwq.cannabis@waterboards.ca.gov](mailto:dwq.cannabis@waterboards.ca.gov)  
Cheri Sanville, California Department of Fish and Wildlife,  
[cheri.sanville@wildlife.ca.gov](mailto:cheri.sanville@wildlife.ca.gov)  
Cliff Johnson, Humboldt County Planning and Building,  
[cjohnson@co.humboldt.ca.us](mailto:cjohnson@co.humboldt.ca.us)



Notice of Applicability  
WQ 2019-0001-DWQ-R1  
WDID #1\_12CC417947

- 6 -

November 15, 2019

# State Waterboard Online Cannabis Water Quality Monitoring & Reporting Program

You completed application 425044 on 02/27/2020 15:52:22

[Return to Dashboard](#)

## SECTION A ENROLLMENT INFORMATION:

Enter WDID for cultivation site:

What year will you be reporting for?



2018

2019

2020

Please choose the reason you are submitting this Monitoring Report:



This is the Annual Monitoring Report required to be submitted by March 1 for the previous calendar year.

I am in the process of terminating Cannabis Cultivation General Order coverage and must submit a final Monitoring Report.

It may take a few moments to retrieve the enrollment information associated with this WDID after you hit "Save and Continue."

## SECTION A ENROLLMENT INFORMATION:

The information below is related to 1\_12CC417947.

Facility Enrollment Type and Discharger Name:

Enrollee - WDR under Cannabis Cultivation General Order for Moffitt, Kurt

County:	Regional Water Quality Control Board:	Order Number:
<input type="text" value="Humboldt"/>	<input type="text" value="1"/>	<input type="text" value="2019-0001-DWQ"/>

Tier And Risk Level:	Cultivation Area sqft:	Disturbed Area sqft:
<input type="text" value="1L"/>	<input type="text" value="30000"/>	<input type="text" value="35000"/>
	Cumulative Cultivation Area sqft.*	Cumulative Disturbed Area sqft.*
	<input type="text" value="30000"/>	<input type="text" value="35000"/>

*\*For sites with multiple enrollments on the same property, report the combined disturbed area and cultivation area of all cannabis cultivation on the property. If this does not apply, leave this section blank.*

Note: 1L = Tier 1 Low Risk  
1M = Tier 1 Moderate Risk  
1H = Tier 1 High Risk

2M = Tier 2 Moderate Risk

2H = Tier 2 High Risk

If the Enrollment Type and Discharger Name above is blank or does not look to be associated with your cannabis cultivation please confirm WDID number 1\_12CC417947 is the WDID number listed on the Notice of Applicability (NOA) issued by the Regional Water Quality Control Board (RWQCB) or State Water Resource Control Board (SWRCB). You can re-enter the WDID by going back to the previous screen.

If you have confirmed the WDID was entered exactly as shown on the NOA and the fields are still blank you will need to contact the RWQCB or SWRCB that issued the NOA.

## SECTION B ANNUAL MONITORING REPORT CANNABIS CULTIVATION GENERAL ORDER

Welcome to the Cannabis Cultivation General Order Annual Monitoring Report Portal. This online tool allows dischargers, also referred to as cannabis cultivators, or representative to electronically submit the Annual Monitoring Report as required by the State Water Resources Control Board General Waste Discharge Requirements and Waiver of Waste Discharge Requirements for Discharges of Waste Associated with Cannabis Cultivation Activities (Cannabis Cultivation General Order). This online portal fulfills the requirement in Attachment B of the Cannabis Cultivation General Order.

The portal consists of the following sections:

Section A: Site Enrollment Information

Section B: Facility Status information for Tier 1 and Tier 2 dischargers characterized as low, moderate, or high risk

Section C: Site Maintenance Status for Tier 1 and Tier 2 dischargers characterized as moderate or high risk

Section D: Storm Water Runoff Monitoring for Tier 1 and Tier 2 dischargers that are characterized as moderate or high risk

Section E: Self Certification of information provided

Questions that are marked with a  symbol are mandatory and must be answered in the application.

At anytime you can close the window and return at a later date to continue at your last saved page.

Click **'Save and Continue'** below to continue.

## SECTION B FACILITY STATUS: Winterization Measures Implemented

### Winter Period:

November 15 to April 1

Please review the Winterization Best Practical Treatment Controls (BPTC), also known as requirements in Attachment A of the Cannabis Cultivation General Order and indicate the facilities compliance with those standard conditions. 'Yes' meaning your facility was in compliance with the standard conditions by the onset of the winter period (listed above), 'Not applicable' meaning the condition does not apply to your specific site, and 'No' meaning the facility did not meet the condition by the onset of the winter period. If you mark 'No' please indicate the compliance date or the expected date of compliance.

### Report Dates MMDDYYYY

Cannabis cultivators shall **not** operate heavy equipment of any kind at the cannabis cultivation site during the winter period, unless authorized. (1) in a site management plan as described below, or (2) for emergency repairs contained in an enforcement order issued by the State Water Board, Regional Water Board, or other agency having jurisdiction. Use of heavy equipment (e.g. agricultural equipment) for routine cannabis cultivation soil preparation or planting may be authorized in a site management plan approved by the applicable Regional Water Board Executive Officer or designee if both of the following conditions are met:

- all soil preparation and planting activities occur outside of the riparian setbacks; and
- all soil preparation and planting activities are located on an average slope equal to or less than five percent (5%) (e.g., valley floor).

Please indicate what best indicates heavy equipment usage at your site during this winter period. 

- No heavy equipment of any kind has been used at the cannabis cultivation site during the winter period.
- Heavy equipment has been or will be used during the winter period as authorized under an approved site management plan.
- Heavy equipment has been or will be used during the winter period for emergency repairs contained in an enforcement order issued by the State Water Board, Regional Water Board, or other agency having jurisdiction.

Unauthorized heavy equipment use occurred after the beginning of the winter period but stopped or will be stopped by:

Cannabis cultivators shall block or otherwise close any temporary access roads to all motorized vehicles no later than the onset of the winter period each year. ⚠️

Not Applicable

Yes

Not completed by the beginning of the winter period but were completed or will be completed by:

Cannabis cultivators shall apply linear sediment controls (e.g., silt fences, wattles, etc.) along the toe of the slope, face of the slope, and at the grade breaks of exposed slopes to comply with sheet flow length at the frequency specified in Attachment A of the Cannabis Cultivation General Order. ⚠️

Not Applicable

Yes

Not completed by the beginning of the winter period but were completed or will be completed by:

Cannabis cultivators shall maintain all culverts, drop inlets, trash racks and similar devices to ensure they are not blocked by debris or sediment. The outflow of culverts shall be inspected to ensure erosion is not undermining the culvert. Culverts shall be inspected prior to the onset of fall and winter precipitation and following precipitation events that produce at least 0.5 in/day or 1.0 inch/7 days of precipitation to determine if maintenance or cleaning is required. ⚠️

Not applicable

Yes

Not completed by the beginning of the winter period but were completed or will be completed by:

Cannabis cultivators shall stabilize all disturbed areas and construction entrances and exits to control erosion and sediment discharges from land disturbance. ⚠️

Not applicable

Yes

Not completed by the beginning of the winter period but were completed or will be completed by:

Cannabis cultivators shall cover and berm all loose stockpiled construction materials (e.g., soil, spoils, aggregate, etc.) that are not actively (scheduled for use within 48 hours) being used as needed to prevent erosion by storm water. The cannabis cultivator shall have adequate cover and berm materials available onsite if the weather forecast indicates a probability of precipitation. ⚠️

Not applicable

Yes

Not completed by the beginning of the winter period but were completed or will be completed by:

Cannabis cultivators shall apply erosion repair and control measures to the bare ground (e.g., cultivation area, access paths, etc.) to prevent discharge of sediment to waters of the state. ⚠️

- Not applicable
- Yes
- Not completed by the beginning of the winter period but were completed or will be completed by:

Were all winterization measures implemented by the onset of the Winter Period?

- Yes
- No

**If winterization had not been completed by the beginning of the winter period:**

What were the outstanding winterization measures? How were they addressed or how will they be addressed?

## SECTION B FACILITY STATUS: Tier Status Confirmation

Stabilization of disturbed areas may change the tier status of a facility. Contact the North Coast Regional Water Quality Control Board at [northcoast.cannabis@waterboards.ca.gov](mailto:northcoast.cannabis@waterboards.ca.gov) if a change in Tier, Risk, Cultivation Area, or Disturbed Area is required. When contacting the Regional Board please reference your WDID number 1\_12CC417947.

Please select one of the following, which best describes your cannabis cultivation activities during 2019: 

- The cultivation occurs completely outdoors with no indoor cultivation component.
- The cultivation occurs both outdoors and indoors and all industrial wastewaters generated by the indoor cultivation is discharged to a community sewer system consistent with the sewer system requirements.
- The cultivation occurs both outdoors and indoors and irrigation tailwater, hydroponic wastewater, or other miscellaneous industrial wastewaters generated by the indoor cultivation is discharged to an on-site wastewater treatment system (such as a septic tank and leach field), to land, or to surface water.
- The cultivation occurs both outdoors and indoors and irrigation tailwater, hydroponic wastewater, or other miscellaneous industrial wastewaters generated by the indoor cultivation is discharged to an appropriate collection tank, and the wastewater in the collection tank is regularly collected by an authorized waste hauler who disposes of the wastewater to a community sewer system consistent with the sewer system requirements.
- No cannabis cultivation or land disturbance related to cannabis cultivation occurred during the reporting period.

**Below is the current discharge information related to the Cannabis Cultivation General Order Enrollment:**

- The site is currently enrolled as Tier 1 Low Risk.
- The Cultivation Area is 30000 sqft
- The Disturbed Area is 35000 sqft

**Do you need to update your tier status, risk level, disturbed area, or cultivation area?**

- Yes
- No

NOTE: 1 acre = 43,560 sqft

**Voluntary Information: If applicable please enter the information below.**

Small Irrigation Use Registration Number:

California Department of Food and Agriculture (CDFA) License Number:

California Department of Fish and Wildlife (CDFW) LSA Self-Certification Application or Notification (Standard or General) Number:

## SECTION B FACILITY STATUS: Third Party Identification

Has there been any change in third party status?

- Yes
- No

**If there has been any change in third party status:** Please describe change in third party status. (company/agent: address: email: phone: etc)

## SECTION E: Certification Cannabis Cultivation General Order

observed summarize the numbers and severity of the violations found during the reporting period, and actions taken or planned to correct the violation and prevent future violations.

★ No violations observed

I certify under penalty of law that I have personally examined and am familiar with the information submitted in this document and all attachments and that, based on my inquiry of the those individuals immediately responsible for obtaining the information, I believe that the information is true, accurate, and complete. I am aware that there are significant penalties for submitting false information, including the possibility of fine and imprisonment.

★ Full legal name of the individual signing: Paula Pavlich

★ Title of the individual signing: (e.g., Owner, Consultant, Cultivator) Consultant

★ Date of signature: 02/27/2020

## SUPPLEMENTAL REPORTING - NORTH COAST REGION: Overview

Note: The following two pages fulfil supplemental reporting requirements as outlined by [Investigative Order No. R1-2019-0023](#) (North Coast Regional Supplement to Annual Monitoring and Reporting Requirements for Statewide Cannabis General Order WQ 2019-0001-DWQ).

Questions that are marked with a ★ symbol are mandatory and must be answered in the application.

Upon completion of supplemental reporting questions, you will be directed to the certification and submission page (Section E). Once you have certified and submitted your online Annual Report, you will be able to see a copy of your report by clicking "Review your answers" in the Applications Dashboard. A copy of the report will also be sent directly to the email address that was used to login to the portal, as well as to the North Coast Regional Water Quality Control Board. Please be advised that a copy of the Annual Report must be retained onsite and made available upon request.

Click 'Save and Continue' below to continue

## SUPPLEMENTAL REPORTING - NORTH COAST REGION: Quantitative Site Characterization

Note: Enter zero or N/A as appropriate for questions that are non-applicable, based on operation type

### Outdoor (Full Sun) Operations

★ Sum of cultivation area(s) (sq ft) 0

★ # of Adult Plants (per harvest) 0

★ Planting Medium na

### Mixed-Light Operations

★ Sum of cultivation area(s) (sq ft) 30000

★ # of Adult Plants (per harvest) 4000

★ Planting Medium soil bags

### Indoor Operations

★ Sum of cultivation area(s) (sq ft) 0

★ # of Adult Plants (per harvest) 0



Total sum of all cultivation areas (all types) (sq ft)	30000
Shortest distance from any cultivation area (ft) to nearest Class I Watercourse	200+
Shortest distance from any cultivation area (ft) to nearest Class II Watercourse	200+
Shortest distance from any cultivation area (ft) to nearest Class III Watercourse	200+
Average slope of cultivated area (%)	3
Number of road crossings of surface waters	7
Length of unpaved roads on enrolled parcel(s)	2 - 5 miles
Total water storage capacity (gallons)	358000
Total annual nitrogen use (lbs)	5.6
Total annual phosphorus use (lbs)	3.7

## SUPPLEMENTAL REPORTING - NORTH COAST REGION: Water Use

### Water Input to Storage for Cannabis Plants (gallons per month)

Note: Multiple cases of a single source category should be combined (e.g. if there are multiple wells, report monthly sum from all as a single source). Additionally, a new source category has been added (Hydrologically Connected Well(s)) for wells that are in close proximity to surface water.

#### Input Source 1

Input Source 1	Groundwater Well(s)
January	0
February	0
March	40000

★	May	50000
★	June	50000
★	July	50000
★	August	50000
★	September	50000
★	October	50000
★	November	0
★	December	0

### Input Source 2

<b>Input Source 2</b>	None
January	0
February	0
March	0
April	0
May	0
June	0
July	0
August	0
September	0
October	0
November	0
December	0

### Input Source 3

<b>Input Source 3</b>	None
January	0
February	0

iv .1	<input type="text"/>
April	<input type="text" value="0"/>
May	<input type="text" value="0"/>
June	<input type="text" value="0"/>
July	<input type="text" value="0"/>
August	<input type="text" value="0"/>
September	<input type="text" value="0"/>
October	<input type="text" value="0"/>
November	<input type="text" value="0"/>
December	<input type="text" value="0"/>

## Water Applied to Cannabis Plants (gallons per month)

Note: If water is applied from storage, select the type of storage as the Application Source, rather than the original source of the water.

### Application Source 1

Application Source 1	Tank(s)
★ January	<input type="text" value="0"/>
★ February	<input type="text" value="0"/>
★ March	<input type="text" value="40000"/>
★ April	<input type="text" value="50000"/>
★ May	<input type="text" value="50000"/>
★ June	<input type="text" value="50000"/>
★ July	<input type="text" value="50000"/>
★ August	<input type="text" value="50000"/>
★ September	<input type="text" value="50000"/>
★ October	<input type="text" value="50000"/>
★ November	<input type="text" value="0"/>
★ December	<input type="text" value="0"/>

## Application Source 2

Application Source 2

None

- January
- February
- March
- April
- May
- June
- July
- August
- September
- October
- November
- December

## Application Source 3

Application Source 3

None

- January
- February
- March
- April
- May
- June
- July
- August
- September
- October
- November

If "Other" is selected for either Input Source or Application Source please provide a brief description here:

How was water use estimated?  Expected Use Based on Plant Count

If estimation method is "Other" please provide a brief description here:

Submission

## SUBMISSION PAGE

NOTICE PURSUANT TO INFORMATION PRACTICES ACT OF 1977 (CIV. CODE. § 1798.17) The State Water Resources Control Board is requesting personal identifying information about the discharger and the person filing this report for the monitoring and reporting program required by the statewide General Waste Discharge Requirements and Waiver of Waste Discharge Requirements for Discharges of Waste Associated with Cannabis Cultivation Activities (General Order) and Waiver of Waste Discharge Requirements and General Water Quality Certification for Discharges of Waste Resulting from Cannabis Cultivation and Associated Activities or Operations with Similar Environmental Effects In the North Coast Region (Regional Order). The agency officials responsible for this system of records are Kevin Porzio (General Order), Senior Engineer, whose business address is 1001 I Street, 15th Floor, Sacramento, CA 95814 and whose business telephone is (916) 341-6914 and Kason Grady (Regional Order), Senior Engineer, whose business address is 5550 Skylane Boulevard, Santa Rosa, CA 95403 and whose business telephone is (707) 576-2220. Upon request, the agency official(s) shall inform an individual regarding the location of his or her records and the categories of any persons who use the information in these records.

The State Water Resources Control Board is empowered to require the submission of personal identifying information by California Water Code sections 1228 and 13260. Failure to provide the mandatory information for General Order Monitoring and Reporting Program can result in the imposition of administrative civil liability in the amount of \$1,000 per day.

This personal identifying information is collected to facilitate better water management and waste discharge management by the State Water Resources Control Board. The State Water Resources Control Board will not automatically post personal identifying information to public databases. However, the State Water Resources Control Board may be legally required to disclose personal identifying information under any of the circumstances described in Civil Code, section 1798.24. Such circumstances may include, but are not limited to, responding to a request pursuant to the California Public Records Act or responding to a subpoena from a federal agency.

# State Waterboard Online 2018 Cannabis Water Quality Monitoring & Reporting Program

You completed application 412532 on 03/20/2019 16:39:00

[Return to Dashboard](#)

## SECTION A ENROLLMENT INFORMATION:

★ Enter WDID for cultivation site:

It may take a few moments to retrieve the enrollment information associated with this WDID after you hit "Save and Continue."

## SECTION A ENROLLMENT INFORMATION:

WDID Number 1B171807CHUM is Enrolled Under Order Number:

★

Facility Enrollment Type and Discharger Name:

★

If the Enrollment Type and Discharger Name above is blank or does not look to be associated with your cannabis cultivation please confirm WDID number 1B171807CHUM is the WDID number listed on the Notice of Applicability (NOA) issued by the Regional Water Quality Control Board (RWQCB) or State Water Resource Control Board (SWRCB). You can re-enter the WDID by going back to the previous screen.

If you have confirmed the WDID was entered exactly as shown on the NOA and the fields are still blank you will need to contact the RWQCB or SWRCB that issued the NOA.

## REGIONAL ORDER NO. R1-2015-0023: Annual Report Overview

**Note:** If the site/property was transitioned to the Statewide Cannabis General Order (WQ 2017-0023-DWQ) in 2018, please complete the Annual Report for that Order first by entering your WDID associated with the Statewide Cannabis General Order (format example: 1\_23CC456789). You will be directed back to this page once you have completed the Annual Report for the Statewide Cannabis General Order.

Welcome to the Annual Monitoring and Reporting Portal for North Coast Regional Order No. 2015-0023 Waiver of Waste Discharge Requirements and General Water Quality Certification for Discharges of Waste Resulting from Cannabis Cultivation and Associated Activities or Operations with Similar Environmental Effects in the North Coast Region (Regional Cannabis Order). This application allows cannabis dischargers to electronically submit their Annual Report pursuant to Water Code section 13267 as required by the Regional Cannabis Order. The portal consists of the following sections:

- Section 1: Enrollment and Site Information
- Section 2: Compliance with Standard Conditions
- Section 3: Quantitative Site Characterization
- Section 4: Water Use
- Section 5: Certification

Questions that are marked with a ★ symbol are mandatory and must be answered in the application.

Click 'Save and Continue' below to continue.

## REGIONAL ORDER NO. R1-2015-0023: Enrollment and Site Information

Note: This Annual Report will correspond to the following Enrollment:





# 1B171807CHUM Enrollee - Waiver for Moffitt, Kurt

If the enrollment information listed above does not appear to be associated with your cannabis cultivation please confirm that the Regional Order WDID listed above (format example: 1B123456CHUM) matches the number listed on the Notice of Applicability (NOA) issued by the North Coast Regional Water Quality Control Board (NCRWQCB). If you need to correct the WDID you can use the "Prev" button to return to the page on which the WDID was entered, without losing any saved changes.

If you have confirmed the WDID was entered exactly as shown on the NOA and the information listed above is still incorrect, please contact the NCRWQCB at (707) 576- 2676 or by email at northcoast.cannabis@waterboards.ca.gov.

County  Humboldt

APN(s) 

Tier  2 If tier 2 or 3 answer the following:

Date Water Resource Protection Plan developed

Date instream work completed (if applicable)

Planned date to begin instream work (if applicable)

Discharger Relationship to Property   Owner  Operator  Owner and Operator

Report Preparer  Authorized Representative Authorized Representative Organization (if applicable)

## REGIONAL ORDER NO. R1-2015-0023: Compliance with Standard Conditions

### Site in Compliance with Standard Conditions?

Note: If a standard condition is not met, indicate "No" and provide expected date of compliance. If a standard condition has been met or is not applicable indicate "Yes" the standard condition has been met (for example, if there are no stream crossings onsite, Standard Condition 2 would be met and "Yes" would be the proper choice).

  Yes  
 No

**Standard Condition 1: Site Maintenance, erosion control, and drainage features**

If "No", expected date of compliance for SC 1

  Yes  
 No

**Standard Condition 2: Stream crossing maintenance**

If "No", expected date of compliance for SC 2

**Standard Condition 3: Riparian and wetland protection management**

- Yes
- No

If "No", expected date of compliance for SC 3

03/31/2020

**Standard Condition 4: Spoils management**

- Yes
- No

If "No", expected date of compliance for SC 4

**Standard Condition 5: Water storage and use**

- Yes
- No

If "No", expected date of compliance for SC 5

**Standard Condition 6: Irrigation runoff**

- Yes
- No

If "No", expected date of compliance for SC 6

**Standard Condition 7: Fertilizers and soil amendments**

- Yes
- No

If "No", expected date of compliance for SC 7

**Standard Condition 8: Pesticides and herbicides**

- Yes
- No

If "No", expected date of compliance for SC 8

**Standard Condition 9: Petroleum products and other chemicals**

- Yes
- No

If "No", expected date of compliance for SC 9

- Yes
- No

Standard Condition  
**Cultivation-related waste**

If "No", expected date of compliance for  
SC 10

 **Standard Condition 11: Refuse  
and human waste**  Yes  
 No

If "No", expected date of compliance for  
SC 11

## REGIONAL ORDER NO. R1-2015-0023: Quantitative Site Characterization

Note: Enter zero or N/A as appropriate for questions that are non-applicable, based on operation type

### Outdoor (Full Sun) Operations

 Sum of cultivation area(s) (sq ft)

 # of Adult Plants (per harvest)

 Planting Medium

### Mixed-Light Operations

 Sum of cultivation area(s) (sq ft)

 # of Adult Plants (per harvest)

 Planting Medium

### Indoor Operations

 Sum of cultivation area(s) (sq ft)

 # of Adult Plants (per harvest)

 Planting Medium

   
Total sum of all cultivation areas (all  
types) (sq ft)

   
Shortest distance from any cultivation  
area (ft) to nearest Class I Watercourse

   
Shortest distance from any cultivation  
area (ft) to nearest Class II Watercourse

   
Shortest distance from any cultivation  
area (ft) to nearest Class III Watercourse

- Average slope or cultivated area
- Number of road crossings of surface waters
- Length of unpaved roads on enrolled parcel(s)
- Total water storage capacity (gallons)
- Total annual nitrogen use (lbs)
- Total annual phosphorus use (lbs)

REGIONAL ORDER NO. R1-2015-0023: Water Use

## Water Input to Storage (gallons per month)

Note: Multiple cases of a single source category should be combined (e.g. if there are multiple wells, report monthly sum from all as a single source). Additionally, a new source category has been added (Hydrologically Connected Well(s)) for wells that are in close proximity to surface water.

### Input Source 1

Input Source 1	<input type="text" value="Spring(s)"/>
January	<input type="text" value="14000"/>
February	<input type="text" value="13500"/>
March	<input type="text" value="14000"/>
April	<input type="text" value="0"/>
May	<input type="text" value="0"/>
June	<input type="text" value="0"/>
July	<input type="text" value="0"/>
August	<input type="text" value="0"/>
September	<input type="text" value="0"/>
October	<input type="text" value="0"/>
November	<input type="text" value="0"/>
December	<input type="text" value="0"/>

Input Source 2

Input Source 2	Rain
January	41277
February	37897
March	32442
April	15100
May	6291
June	873
July	290
August	2100
September	4400
October	14555
November	35005
December	38890

Input Source 3

Input Source 3

January	0
February	0
March	0
April	0
May	0
June	0
July	0
August	0
September	0
October	0
November	0

# Water Applied to Plants (gallons per month)

Note: If water is applied from storage, select the type of storage as the Application Source, rather than the original source of the water.

## Application Source 1

Application Source 1	Pond(s)
★ January	0
★ February	0
★ March	0
★ April	0
★ May	0
★ June	0
★ July	58000
★ August	72000
★ September	75000
★ October	45000
★ November	0
★ December	0

## Application Source 2

Application Source 2	Other
January	0
February	0
March	0
April	17500
May	25000
June	40000
July	0



- AL ST
- September
- October
- November
- December

### Application Source 3

#### Application Source 3

- January
- February
- March
- April
- May
- June
- July
- August
- September
- October
- November
- December

If "Other" is selected for either Input Source or Application Source please provide a brief description here: **Hard Tank water storage -**

How was water use estimated?  **Expected Use Based on Plant Count**  
 If estimation method is "Other" please provide a brief description here:

No  Yes  
 Was this site transferred to the Statewide Cannabis Order during 2018?

### REGIONAL ORDER NO. R1-2015-0023: Certification

Note: This Annual Report will be submitted for the following Enrollment:

**1B171807CHUM Enrollee - Waiver for Moffitt, Kurt**

I certify under penalty of law that I have personally examined and am familiar with the information submitted in this document and that, based on my collection of this information or my inquiry of those individuals immediately responsible

significant penalties for submitting false information, including the possibility of fine and imprisonment.

Full legal name of the individual signing

Title of individual signing: (e.g., Owner, Consultant)

Date of signature

## Submission

# SUBMISSION PAGE

NOTICE PURSUANT TO INFORMATION PRACTICES ACT OF 1977 (CIV. CODE, § 1798.17) The State Water Resources Control Board is requesting personal identifying information about the discharger and the person filing this report for the monitoring and reporting program required by the statewide General Waste Discharge Requirements and Waiver of Waste Discharge Requirements for Discharges of Waste Associated with Cannabis Cultivation Activities (General Order) and Waiver of Waste Discharge Requirements and General Water Quality Certification for Discharges of Waste Resulting from Cannabis Cultivation and Associated Activities or Operations with Similar Environmental Effects In the North Coast Region (Regional Order). The agency officials responsible for this system of records are Kevin Porzio (General Order), Senior Engineer, whose business address is 1001 I Street, 15th Floor, Sacramento, CA 95814 and whose business telephone is (916) 341-6914 and Kason Grady (Regional Order), Senior Engineer, whose business address is 5550 Skylane Boulevard, Santa Rosa, CA 95403 and whose business telephone is (707) 576-2220. Upon request, the agency official(s) shall inform an individual regarding the location of his or her records and the categories of any persons who use the information in these records.

The State Water Resources Control Board is empowered to require the submission of personal identifying information by California Water Code sections 1228 and 13260. Failure to provide the mandatory information for General Order Monitoring and Reporting Program can result in the imposition of administrative civil liability in the amount of \$1,000 per day.

This personal identifying information is collected to facilitate better water management and waste discharge management by the State Water Resources Control Board. The State Water Resources Control Board will not automatically post personal identifying information to public databases. However, the State Water Resources Control Board may be legally required to disclose personal identifying information under any of the circumstances described in Civil Code, section 1798.24. Such circumstances may include, but are not limited to, responding to a request pursuant to the California Public Records Act or responding to a subpoena from a federal agency.