

# Vegetation Management

Activity Specific Erosion and Sediment Control Plan  
(A-ESCP)



For questions or concerns, please contact your assigned PG&E  
Environmental Lead identified in the ERTC.

Prepared by:  
PG&E Construction Stormwater Group

August 2020  
Version 2



# TABLE OF CONTENTS

<b>1.0</b>	<b>WHAT IS VEGETATION MANAGEMENT?</b> .....	<b>1</b>
<b>2.0</b>	<b>VEGETATION MANAGEMENT WATER QUALITY PROCEDURES</b>	<b>2</b>
<b>3.0</b>	<b>INSPECTION AND MAINTENANCE REQUIREMENTS</b> .....	<b>7</b>
<b>4.0</b>	<b>TROUBLESHOOTING</b> .....	<b>8</b>
<b>5.0</b>	<b>WORK COMPLETION</b> .....	<b>9</b>

## Attachments

<b>Attachment A</b>	<b>Fiber Roll Detail</b>
<b>Attachment B</b>	<b>Silt Fence Detail</b>
<b>Attachment C</b>	<b>Storm Drain Inlet Protection Detail</b>
<b>Attachment D</b>	<b>Tracking Control Detail</b>
<b>Attachment E</b>	<b>Pre-Rain Inspection Checklist</b>

## References

### Referenced Activity Specific Erosion and Sediment Control Plans (A-ESCPs)

GH	Good Housekeeping
SM	Stockpile Management
BC	Basecamp Wood Processing
RM	Road Maintenance

### Associated BMP Fact Sheets

EC-1	Scheduling	SE-7	Street Sweeping and Vacuuming
EC-2	Preservation of Existing Vegetation	SE-10	Storm Drain Inlet Protection
EC-3	Hydraulic Mulch	SE-13	Compost Socks and Berms
EC-4	Hydroseed	TC-1	Stabilized Construction Exit
EC-5	Soil Binders	TC-2	Stabilized Construction Roadway
EC-6	Straw Mulch	WE-1	Wind Erosion Control
EC-7	Covers & Erosion Control Blankets	NS-4	Temporary Stream Crossing
EC-8	Wood Mulch	NS-9	Vehicle and Equipment Fueling
EC-9	Earth Dikes & Drainage Swales	NS-10	Vehicle and Equipment Maintenance
EC-10	Velocity Dissipation Devices	NS-14	Material Over Water
EC-14	Compost Blankets	NS-15	Demolition Adjacent to Water
EC-15	Soil Preparation / Roughening	WM-1	Material Delivery and Storage
EC-16	Non-Vegetative Stabilization	WM-2	Material Use
SE-1	Silt Fence	WM-3	Stockpile Management
SE-3	Sediment Traps	WM-4	Spill Prevention and Control
SE-4	Check Dam	WM-5	Solid Waste Management
SE-5	Fiber Rolls	WM-7	Contaminated Soil Management
SE-6	Gravel Bag Berm	WM-9	Sanitary/Septic Waste Management

# 1.0 WHAT IS VEGETATION MANAGEMENT?

Vegetation management activities are used to maintain a minimum vegetation to conductor clearance required by state and federal regulations. These activities are also intended to reduce the spread and intensity of fires associated with PG&E assets, improve access to facilities for first responders, improve asset protection in the event of a wildfire and improve public safety by contributing to defensible space and lengthening/connecting to existing fuel breaks within communities. Vegetation trimming, removal, skidding, mastication, staging, clearing, grading, and other related work activities associated with vegetation management operations have the potential to release sediment and other pollutants, potentially causing negative impacts to the environment. Pacific Gas & Electric Company (PG&E) implements this A-ESCP as a routine maintenance activity and as a wildfire risk reduction measure.

All PG&E Project Teams, Crews, and Subcontractors are **required** to be familiar with the information within this A-ESCP

This Activity Specific Erosion and Sediment Control Plan (A-ESCP) sets forth **minimum** Best Management Practices (BMPs) for all PG&E Vegetation Management work that are to be implemented year-round.

**GOAL:** Prevent the discharge of pollutants, including sediment, and the contamination of soil during vegetation management activities to limit negative impacts to the environment and aquatic life.



**Stop Work and contact the PG&E Environmental Lead if work near surface waters (creeks, streams, drainages, rivers, wetlands, etc.), not already addressed in the ERTC, is required.**

Failure to consider/plan for water quality impacts not only can impair the environment, but may also result in operational/work delays, fines and the loss of goodwill from regulatory agencies and the public.

If specific environmental concerns are encountered, or if the procedures contained within this A-ESCP prove ineffective, contact the Environmental Lead. Several predominant work activities of concern associated to Vegetation Management include:

- **Overland Access**
- **Debris Management**
- **Skidding**
- **Staging/Laydown Areas**
- **Site Stabilization**



**Plan for Success.** Monitor the forecast and schedule activities accordingly. Observe and minimize impact to drainages and concentrated run-off paths. Strategically determine material, equipment, waste, fueling, storage and maintenance locations for areas of least potential impact.

## 2.0 VEGETATION MANAGEMENT WATER QUALITY PROCEDURES

The measures described in this A-ESCP apply to all PG&E projects with Vegetation Management activities throughout the year. Employees and Contractors shall follow Best Management Practices (BMPs) to protect storm water runoff from vegetation management associated materials and/or pollutants as laid out in this Vegetation Management Activity Specific Erosion and Sediment Control Plan (A-ESCP).

### **Minimum Best Management Practices (BMPs) to reduce Environmental Impacts during Vegetation Management Activities:**

Minimum BMPs during Vegetation Management Activities	
1	Conduct work during dry weather, when possible. Monitor the weather and maintain an adequate buffer from drainages, watercourses, and flowlines. Minimize or avoid work during intense or extended storms including those that produce run-off from the work area. Implement appropriate Erosion Control, Sediment Control, and Run-off Control BMPs.
2	Fuel and maintain vehicles and equipment in a proper, designated area located at least 50 ft away from downstream drainage facilities and watercourses.
3	Remove debris in a manner that prevents it from entering sensitive areas.
4	When needed, and in the steeper areas, use sediment controls to prevent sediment and/or debris from leaving the work area. Sediment controls should be placed on contour, every five 5 feet of elevation change. Please contact the assigned Storm Water SME to schedule a site visit to prepare recommendations for sediment control BMPs.
5	Avoid skidding, operating equipment, and driving on saturated soil or mud. These practices tend to create rutting and further exacerbate soil saturation and instability. If rutting is observed, stop work in the area and repair rutting with smaller equipment such as skid steers or by hand when weather allows.
6	For constructed access routes, minimize soil exposure and compaction to protect ground vegetation and the duff layer.
7	Locate portable toilets away from drainages and inlets (50 ft if possible). Toilets must include a containment tray. Protect from tipping, especially in high wind areas.
8	Have spill kits within reach during activities with potential to release pollutants, such as vehicle and equipment fueling and maintenance.
9	When possible, buck logs onsite to minimize need for skidding material.
10	Avoid skidding across seasonal waterways and riparian areas.
11	Regrade areas to match original line and grade as needed.

**Sediment Control BMP Examples:** Bio-degradable Fiber Roll, Compost Sock, and Vegetative Debris Berm.

**Erosion Control BMP Examples:** Native Wood Mulch, Weed Free Straw Mulch, Hydraulic Mulch, Tackifier, Biodegradable/Natural Fiber Rolled Blanket, Plastic Sheeting, and Rolled Filter Fabric.

**Run-off Control BMP Examples:** Gravel Bags, Check Dams, and Sediment Traps.

## 2.1 Good Housekeeping

Good Housekeeping includes Best Management Practices (BMPs) to minimize contact of potential pollutants with stormwater, discharge of pollutants to storm drains or surface water, and the contamination of soil.

All PG&E Projects, Crews, and Subcontractors are required to be familiar with and follow, at a minimum, housekeeping and stockpile management standards as detailed in the Good Housekeeping A-ESCP and Stockpile Management A-ESCP prior to starting work. Should site personnel be unfamiliar with the requirements for Good Housekeeping or Stockpile Management, PG&E expects that they will obtain a copy of the A-ESCPs which are available on SharePoint. Good Housekeeping and Stockpile Management A-ESCP requirements may apply to all activities within this Plan, and therefore are not mentioned in each subsection.

### Requirements: (Avoidance and Minimization Measures)

**Good Housekeeping must take place at every job, parking area and laydown yard year-round.**

- Use effective BMPs to reduce or prevent pollutants in all water discharges.
- Store hazardous liquids, wastes, and all chemicals in watertight containers with appropriate secondary containment to prevent any spillage or leakage, or in a completely enclosed storage shed.
- Properly locate, secure, and maintain sanitation facilities which includes providing a spill/leak tray.
- Cover waste disposal containers at the end of each day and prior to and during precipitation.
- Keep spill cleanup kits on-site with fueling and maintenance vehicles, and accessible at all times. Train all personnel on the location, use, and contents of the spill kit(s). If safe, stop and clean spills (with absorbents) immediately. Do not wash the spill with water. Notify the Environmental Lead and project foreman. Dispose of materials properly and cover the spill or contaminated area prior to precipitation.
- Properly maintain vehicles, clean leaks immediately, and dispose of materials properly. Fuel and maintain vehicles and equipment in a proper, designated area located at least 50 ft away from downstream drainage facilities and watercourses. Monitor the area regularly.
- Control sediment tracking onto paved surfaces by utilizing stabilized entrances and implementing street sweeping.
- Control dust and other airborne pollutants and respond quickly to airborne pollutant observation. Provide a water truck if there is potential for dust and cover or wet stockpiles that have potential for wind erosion.



- Upon completion, remove temporary, non-biodegradable BMPs and equipment from the site. Clear debris, materials, and contaminants and return drainage ways to their pre-existing line and grade. Cover disturbed soil areas with a combination of temporary and permanent vegetative stabilization measures.

## 2.2 Overland Access

### Requirements: (Avoidance and Minimization Measures)

- Vehicles and equipment must use pavement, established access routes and previously disturbed areas to the extent practicable.
- Inspect roads frequently during all operations.
- Document road conditions prior to use. Include the locations and conditions of culverts and other drainage features such as roadside ditches, rolling dips, water bars etc.
- Restrict use if road damage such as excessive surface displacement or rutting is occurring.
- Delay off-road work after storm events until soil is not overly saturated.
- Limit or eliminate vehicle tracking of sediment onto paved roadways.
- Avoid vehicle and equipment travel on saturated soil or mud if possible.
- For constructed access routes, minimize soil exposure and compaction to protect ground vegetation and the duff layer.
- When crossing roadside ditches or small swales, utilize plates or matting to bridge the flow line.
- Stabilize soils where steep slopes, erodible soils, or high traffic volume increases the potential for erosion by installing sediment controls and/or erosion controls.
- Repair roads and access routes at end of work activity to original line and grade or better, which includes the restoration of roadway drainage features.
- Avoid use of tracked equipment outside of work area and use low pressure, wide tire equipment when possible.
- Additional practices, such as rock slope protection, gabion structures, or other practices to stabilize the access may be required for new roads. Fill slopes must be properly keyed into underlying soils at the toe of the slope, properly compacted, track walked, and treated with a combination of erosion and sediment control.



## 2.3 Debris Management

### Requirements: (Avoidance and Minimization Measures)

- Keep debris a minimum of 50' from streams, wetlands, ditches, drainage courses, and storm drain inlets. If space is limited to less than 50', provide additional diversion or protection adjacent to the waterway.
- Avoid leaving brush or trimmings below the high-water mark of any drainage or waterway.
- Fall timber away from waterways so that when picked up equipment does not encroach within 50' of the sensitive resource.
- Remove debris in a manner that prevents it from entering streams, wetlands, ditches, drainage courses, and storm drain inlets. Do not create soil disturbance by dragging large brush across the ground.
- Evenly disperse wood chips. Do not leave chips in piles.
- When needed, and in the steeper areas, use sediment controls to prevent sediment and/or debris from leaving the work area.



## 2.4 Skidding

### Requirements: (Avoidance and Minimization Measures)

- Winch logs up steep slopes in situations where conventional skidding could cause erosion.
- Use existing skid trails if they provide the best access.
- Where possible, keep grade of skid trail less than 15%.
- Limit the length and quantity of skid trails.
- Regrade areas to match original line and grade as needed.
- Fill, uniformly compact and track-walk ruts. Install sediment control BMPs on steep slopes.



- Cover exposed soil with wood chips, mulch or similar.
- When possible, buck logs onsite to minimize need for skidding material.
- **Do not skid across seasonal waterways, drainages, ditches or through riparian areas.**
- Break up the surface water flow length of large skid trails to avoid erosion and creating channelized flows. Surface breaks include but are not limited to fiber rolls, water bars, rolling dips, and wood chip berms.
- When skidding is completed, or ongoing if for more than one week, all disturbed areas must be inspected to ensure that soils are properly stabilized, BMPs are in place, and there is no potential for erosion or water quality impacts.



## 2.5 Staging & Parking Areas

### Requirements: (Avoidance and Minimization Measures)

- Perimeter controls must be installed around stockpiles (may include earthen berms, fiber roll, or silt fence). Stockpile protection must take place year-round.
- Locate stockpiles away from drainage systems such as swales and drainage inlets.
- Maintain an adequate supply of BMP materials on site before rain events! At a minimum, the materials should include fiber rolls, gravel bags, and plastic sheeting.
- Locate portable toilets away from drainages and inlets (50 ft if possible). Toilet must include a containment tray and should be protected from tipping, especially in high wind areas.
- Provide a tray to contain spills and minor leaks from vehicles, equipment, or materials.
- Have Spill Kit within reach during activities with potential to release pollutants, such as vehicle and equipment fueling and maintenance.
- Allow only properly maintained vehicles and equipment onto the site.
- Park vehicles on hard surfaces and away from drainages, when feasible.
- Place all equipment and vehicles, which are to be fueled, maintained, or stored, in a designated area fitted with appropriate BMPs.
- Properly dispose of all solid and liquid waste.



## 2.6 Site Stabilization

### Requirements: (Restoration Measures)

- Upon completion of work, stabilize all work-related disturbed soils to return the area to pre-existing condition or equivalent which may include gravel/rock, wood mulch, straw mulch, natural fiber/biodegradable rolled blanket, and/or seeding.
- Return roads to pre-existing line and grade or better which includes any necessary rut repair. Compact or stabilize (gravel) the surface to match pre-existing conditions or better.
- Restore drainage features (water bars, rolling dips, culverts, etc.) to pre-existing conditions.
- Obtain appropriate guidance for water bar, rolling dip or culvert installation for newly constructed roads. If necessary, contact the Environmental Lead.
- Cover all project related disturbed soil areas with temporary cover (mulch or biodegradable blanket). Additionally, implement a means to establish permanent vegetative stabilization (seed, fertilizer, soil amendments, ripping/soil aeration, etc.) in areas that are not subject to continuous soil cover establishment via droppings from tree canopy.
- Install biodegradable fiber rolls to protect against any transport of sediment offsite or to environmentally sensitive areas.
- Remove all equipment, material, and waste.



## 3.0 INSPECTION AND MAINTENANCE REQUIREMENTS

- Work areas and implemented BMPs should be inspected for proper functionality weekly, prior to forecast rain events, daily during extended rain events, and after the conclusion of rain events. An inspection checklist is included as Attachment E.
- During certain conditions it may be necessary to inspect work areas more frequently (for example, high winds or extreme heat).
- Repair, re-apply, and/or replace BMPs as needed to keep them functioning properly.
- Sediment shall be removed and disposed of properly when it reaches one-third of the perimeter control height.
- If spilled or leaking materials are discovered, implement appropriate spill control equipment and procedures to completely clean up the potential pollutant to prohibit additional soil contamination or pollutant discharge from the site. If the extent of the impact of the pollutant is unknown, contact the Environmental Lead as soil testing may be necessary.

## 4.0 TROUBLESHOOTING

**Contact the Environmental Lead if any of the following conditions occur:**

- Visually cloudy/muddy water is observed leaving the work or staging area;
- Observed sheen, discoloration, foam, odor, or other pollutant indicator;
- Hazardous substance(s) is/are discharged or spilled; or
- There is potential for a non-visible or any other pollutant discharge.

After hours, please call the Environmental Hotline: **(800) 874-4043**.

If the project receives a written notice or order from any regulatory agency, immediately contact your Environmental Lead for further direction.

<b>Troubleshooting Guide</b>	
<b>Field Condition</b>	<b>Common Solutions Are:</b>
Liquid pollutants on-site	Store in watertight container with appropriate secondary containment or in a fully enclosed storage shed. Maintain spill kit.
Observed spill	Contain spill and clean up contaminants and contaminated soil. Properly dispose of waste. Maintain spill kits on-site.
Potential for tracking to paved surfaces	Install stabilized entrances and implement street sweeping.
Portable toilets	Locate away from drainages, provide a tray to contain spills and minor leaks, protect from tipping, and service regularly.
Waste generated on-site	Provide waste receptacle (dumpster) adequate in size. Cover all waste containers at end of each day and prior to rain events.
Vehicles and equipment stored on-site	Maintain vehicles and equipment in good working condition. Perform fueling and maintenance activities only in areas fitted with appropriate BMPs. Maintain spill kits in case of spill.
Dust and airborne pollutants	Control all sources of airborne pollutants including trash. Apply water to keep soil moist and reduce any potential for dust.
Rain is in the forecast	Deploy applicable erosion, sediment, and run-off controls. Avoid work near drainages, water courses, and flow lines. Minimize work during heavy or extended rain, especially if there is run-off. Avoid driving or operating on saturated surfaces.
Work is complete	Return the site to pre-existing conditions or equivalent. Cover soil that was exposed by the project with BMPs that can be left permanently (no plastic). Restore roadway drainage features.

## 5.0 WORK COMPLETION

Upon completion of work:

- Remove all temporary, non-biodegradable BMPs.
- Remove all equipment from the site.
- Clear all staging areas of any debris, materials, waste, and contaminants.
- Return all drainages to their pre-existing line and grade.
- Return sites and staging areas to pre-existing or equivalent conditions.
- Cover remaining disturbed soil areas with a combination of temporary cover (mulch) and means to establish permanent vegetative stabilization (seed, fertilizer, soil amendments, etc.).



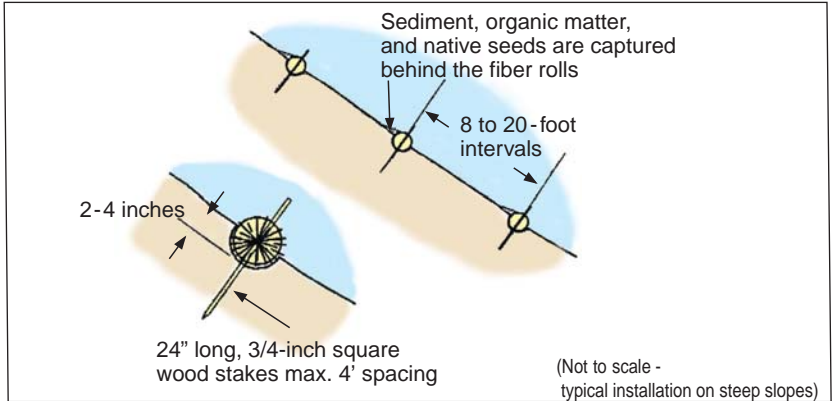
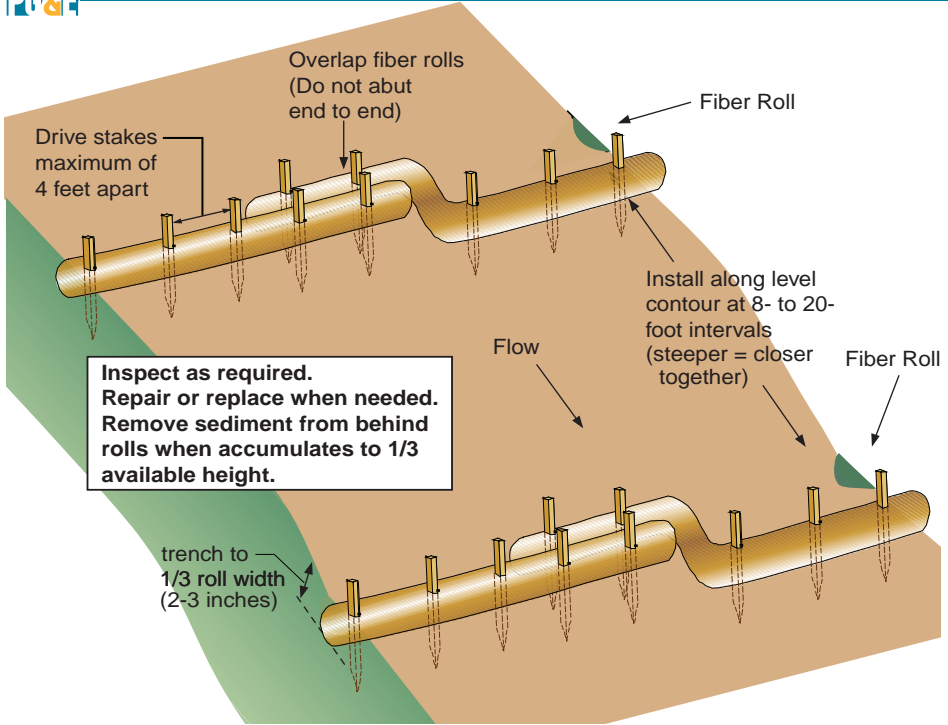

- Install where soil has been exposed on slopes, around stockpiles or along perimeter of work area.
- On slopes space as follows:
  - Slope inclination of 4:1 (H:V) or fatter: Max. interval of 20 ft.
  - Slope inclination between 4:1 and 2:1 (H:V): Max. interval of 15 ft.
  - Slope inclination 2:1 (H:V) or greater: Max. interval of 10 ft.
- Flat areas should not have fiber rolls installed as sediment control, but as perimeter control if needed.
- Bio fiber rolls are typically left in place. If removed, collect and dispose of fiber roll and use accumulated sediment to fill and compact trenches.

# SE-1 SILT FENCE

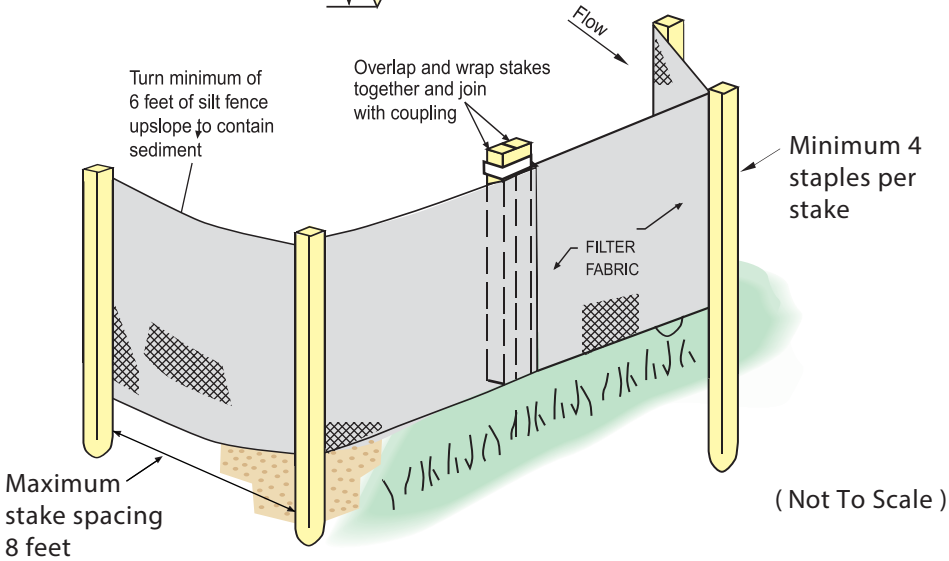
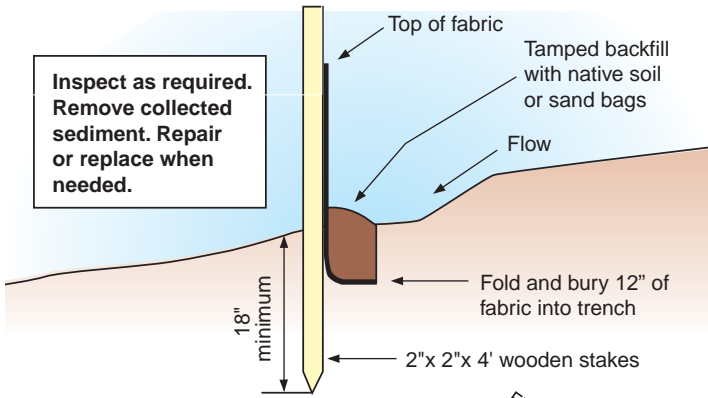

- Install along a level contour, water should not flow along length of fence.
- Length of slope draining to silt fence should not exceed 200 ft.
- Turn ends of silt fence 6 feet uphill to prevent storm water from flowing around the fence.
- Require continuous maintenance during construction, and complete removal after.
- Should not be utilized in areas of high wind or water velocity, or in areas where maintenance access in muddy conditions could be problematic.
- Excavate trench approximately 6 in. wide and 6 in. deep along the line of the proposed silt fence. Key in the bottom of the silt fence a minimum of 12 in.
- When joints are necessary, geotextile should be spliced together only at a support post, with a minimum 6" overlap.
- Construct silt fences with a set back of at least 3 ft from the toe of the slope.
- Construct the length of each reach so that the change in base elevation along the reach does not exceed 1/3 of the height of barrier; in no case should the reach exceed 500 ft.

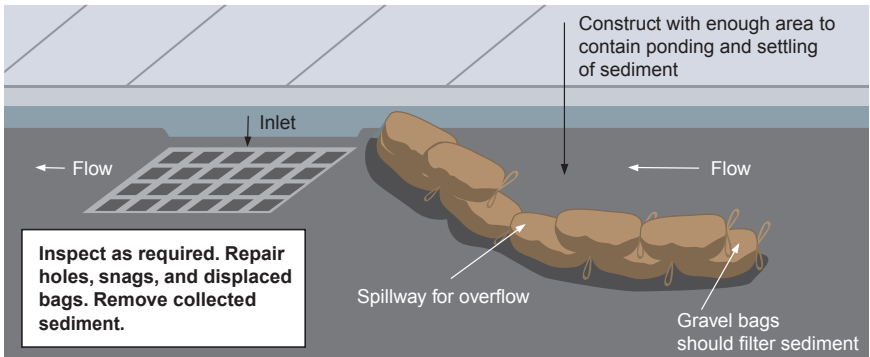

- Use storm drain inlet protection where drains receive construction runoff.
- Install some version even if the inlet is not functional or still under construction.
- Use gravel bag berms to slow runoff to drain and trap sediment.
- In paved areas leave front of drain open to street to handle large flows. Do not cover drain inlet.
- Inspect regularly for functionality and remove accumulated sediment behind berm when build-up is visible.
- Construct such that ponding does not occur on sidewalks or erodible surfaces.

## TC-1 / TC-2 TRACKING CONTROLS

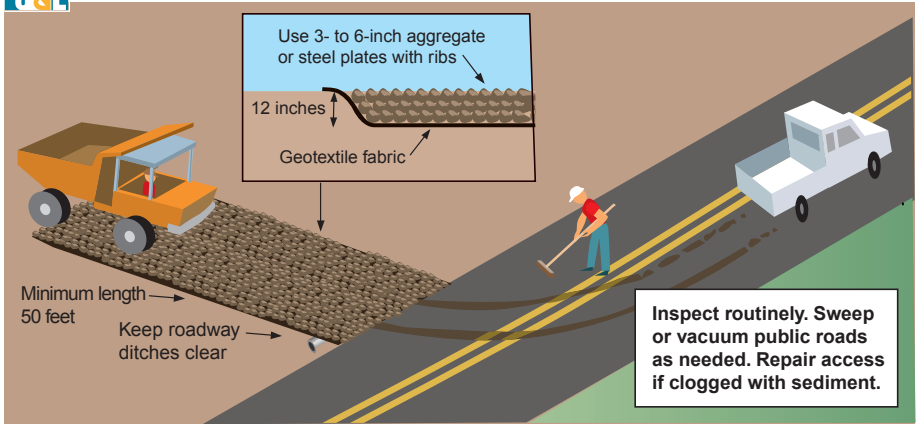

(Not to scale)

- Control the number of points where vehicles can leave the site.
- On loose soil, construct stabilized entrance consisting of 3-to-6 inch aggregate.
- Daily and prior to any rain, remove any sediment or other construction activity-related materials deposited on paved roads by vacuuming or sweeping. Do not use water to wash down paved surface!
- After sweeping is finished, properly dispose of sweeper wastes at an approved dumpsite.

## WM-3 STOCKPILE MANAGEMENT



Protection of stockpiles is a year-round requirement addressing wind and water erosion potential. To properly manage stockpiles:

- Cover with plastic sheeting or filter fabric and surround with gravel bag berm, silt fence, or fiber roll when not actively using.
- Place stockpiles a minimum of 50 feet away from concentrated flows of storm water, drainage courses, and inlets.
- All stockpiles are required to be protected if not in use. If crews are actively adding to or removing from stockpiles, they must protect them if the chance of rain is 50% or greater.
- Secure plastic covering well and check frequently for damage and replace if needed.



**Vegetation Management**

General Information:	
Location:	
Date:	City and Zip:
Forecast % Chance of Rain:	Date Rain Forecast:
Site Stormwater Manager Information:	
Name:	Company:
Emergency Phone Number (24/7):	
Erosion and Sediment Control Contractor Information:	
Name:	Company:
Emergency Phone Number (24/7):	
Current Phase(s) of Work:	
<i>Check ALL boxes that apply to the site.</i>	
<input type="checkbox"/> Vegetation Management Work in Progress	<input type="checkbox"/> Vegetation Management Work Complete
<input type="checkbox"/>	<input type="checkbox"/>
<input type="checkbox"/>	<input type="checkbox"/>
<input type="checkbox"/>	<input type="checkbox"/>
Activities Associated with Current Phase:	
<i>Check ALL boxes that apply to the site.</i>	
<input type="checkbox"/> Overland Access	<input type="checkbox"/> Material Staging
<input type="checkbox"/> Vegetation Removal	<input type="checkbox"/> Site Stabilization
<input type="checkbox"/> Skidding	<input type="checkbox"/> Mobilization
<input type="checkbox"/>	<input type="checkbox"/>
<input type="checkbox"/>	<input type="checkbox"/>
<input type="checkbox"/>	<input type="checkbox"/>

Inspector Information	
Inspector's Name:	Company:
Inspector's Title:	Signature:

