

Jacks Seafood
4 C St.
Eureka, Ca. 95501

Proposed Scope of Work

History

Since opening Jacks Seafood, we have had the same problems dealing with the homeless population in Old Town Eureka. Exacerbating our problem is the fact that our property has an extensive amount of covered area which naturally attracts homeless people.

We have constant problems. Not occasional problems. We have people camping under these covered areas nightly. We have had windows broken on a regular basis. Due to the size of our windows, they are very expensive to replace. Each time a window is broken, it costs a minimum of \$1800 to replace. We have to sell a lot of dinners just to cover the costs of a broken window.

In addition to broken windows, we have regular problems with graffiti, people building campfires, human excrement, people attempting to connect to our electricity and water, etc.

While we realize that a seven foot fence will not solve all of these problems, we believe it will help significantly and it will provide a boundary and a perceived restricted area which will be easier to enforce in terms of trespassing.

Proposed Fence

We are proposing to install a seven-foot-tall black metal fence as shown in the attached drawing. We will install whatever gates and hardware are required to meet egress requirements.

Posts will be set in concrete and the panels will be bolt on making them removeable. If needed, we will set posts in sleeves where needed making the fence easily removeable if the need arises.

Thanks for your consideration.

Sincerely,

Jack Wu

Post size		*W	
in	mm	in	mm
□ 2-1/2"	63.5	94-1/2"	2400
□ 3"	75	95	2411

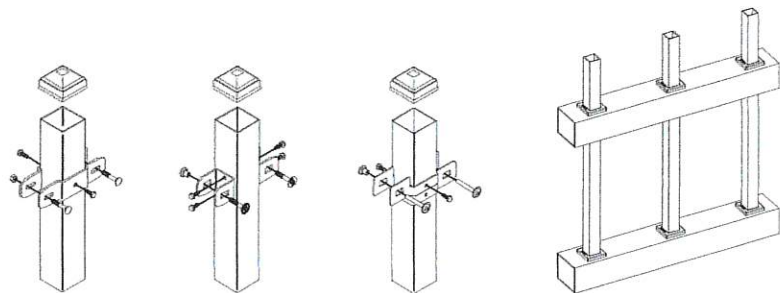
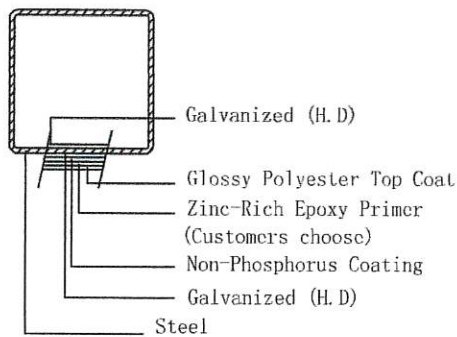
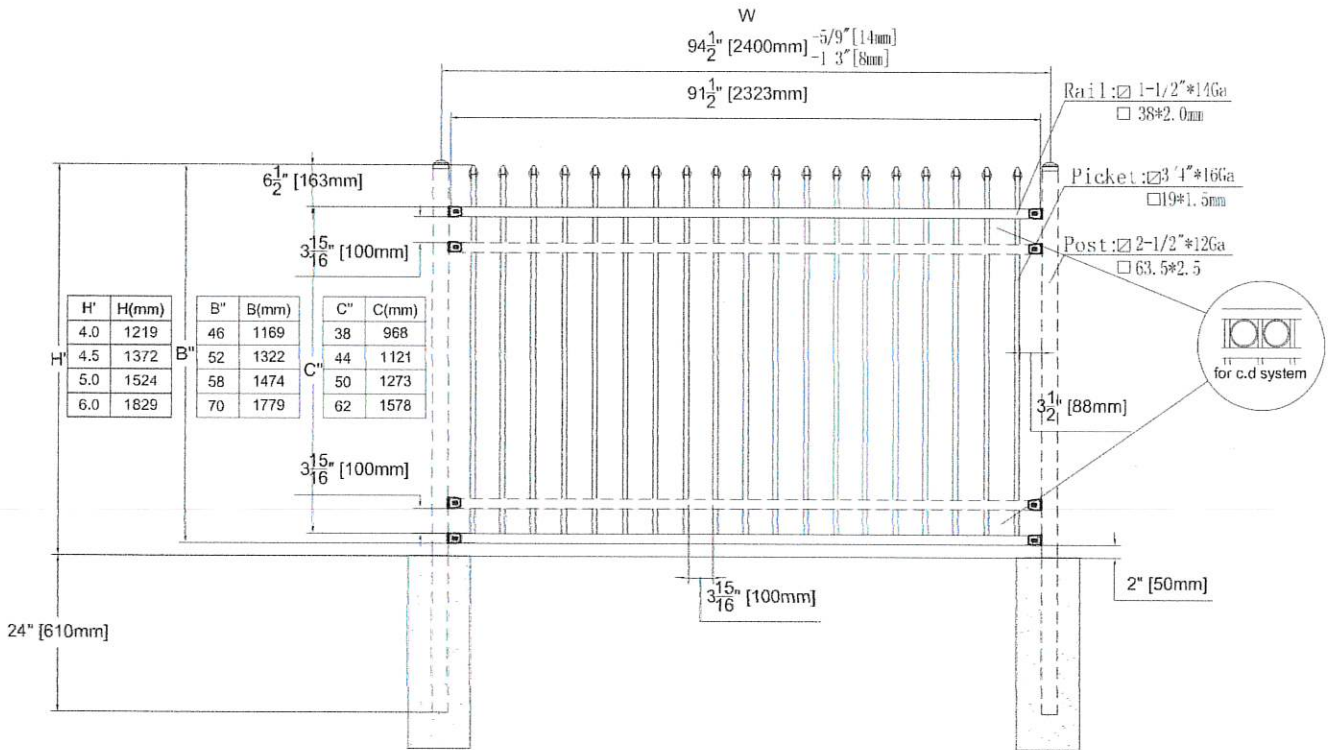

ITEM	Size(mm)	Size(")	Material	Q'Ty
Picket	19*19*1.5	3/4*3/4*1/16Ga	Q195	
Rail	38*38*2.0	1 1/2*1 1/2*1/4Ga	Q235	
Post	63.5*2.5	2 1/2*2 1/2*1/2Ga	Q235	
Design	A. Z	Standardization	D.FF	

CLIENT

USA

Product description

*C**08-N



XCEL Fence Inc
 910 E Cedar St.
 Ontario, CA 91761 USA

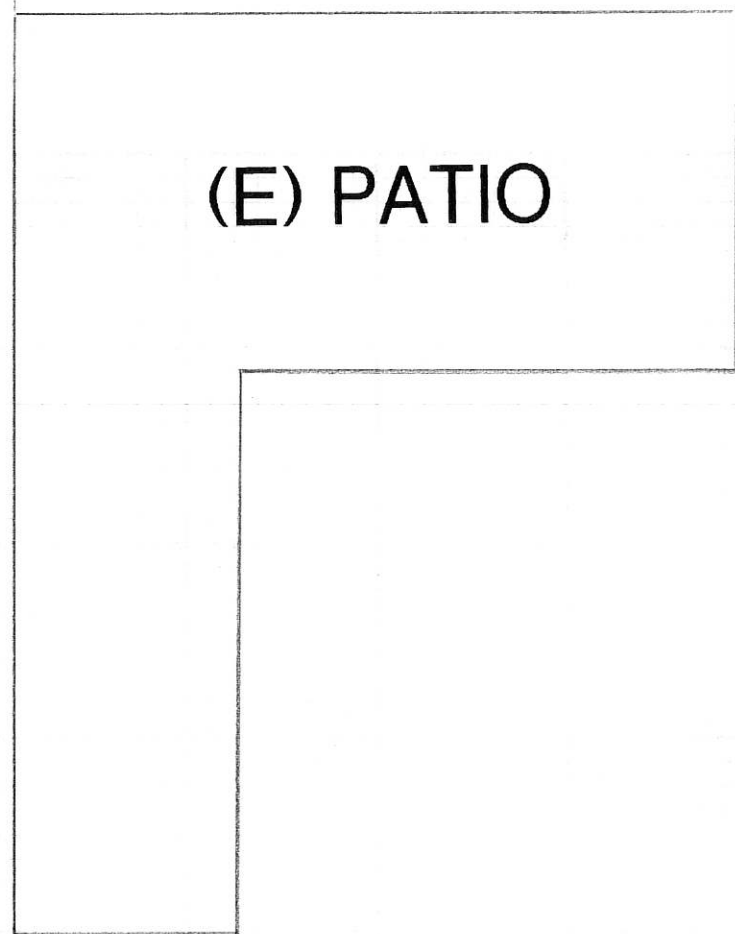

(E) PATIO

(P) GATE
W/PANIC HARDWARE

(P) 7' METAL FENCE
(see attached detail)

(E) COVERED
WALKWAY

(E) COVERED
PATIO

(P) GATES
OPEN DURING
BUSINESS HOURS

JACKS SEAFOOD

4 C STREET
EUREKA, CA

(P) 7' METAL FENCE
(see attached detail)

CONTACT: CHRIS BARRY
(707) 672-3314
chris@shamustbones.com

(E) ALCOVE
FOR TENANT
BATHROOMS

(P) 7' METAL GATE
(see attached detail)

