



LOCATION MAP

NTS

COUNTY OF HUMBOLDT
DEPARTMENT OF PUBLIC WORKS

BAR BELOW IS ONE INCH ON ORIGINAL DRAWING	ENGINEERING DESIGN SECTION	
IF NOT ONE INCH ON THIS SHEET, ADJUST SCALES ACCORDINGLY	CONTRACT NO.: 325701	DESIGNED BY: WMH
	DWG. FILE NAME: HUMCO DESIGN PHASE 3	DRAWN BY: WMH
	PLOT DATE: 03/20/23	REVIEWED BY: AHS
		APPROVED BY: TRS

COUNTY OF HUMBOLDT DEPARTMENT OF PUBLIC WORKS	SHEET 1 OF 12
ADA CURB RAMP IMPROVEMENTS (PHASE 3)	
TITLE SHEET	

COUNTY OF HUMBOLDT
DEPARTMENT OF PUBLIC WORKS
PROJECT PLANS FOR CONSTRUCTION OF
ADA CURB RAMP IMPROVEMENTS
(PHASE 3)
CONTRACT NO. 325701

TO BE SUPPLEMENTED BY STATE OF CALIFORNIA DEPARTMENT OF TRANSPORTATION
STANDARD PLANS, STANDARD SPECIFICATIONS, AND LATEST REVISED 2022 STANDARD SPECIFICATIONS

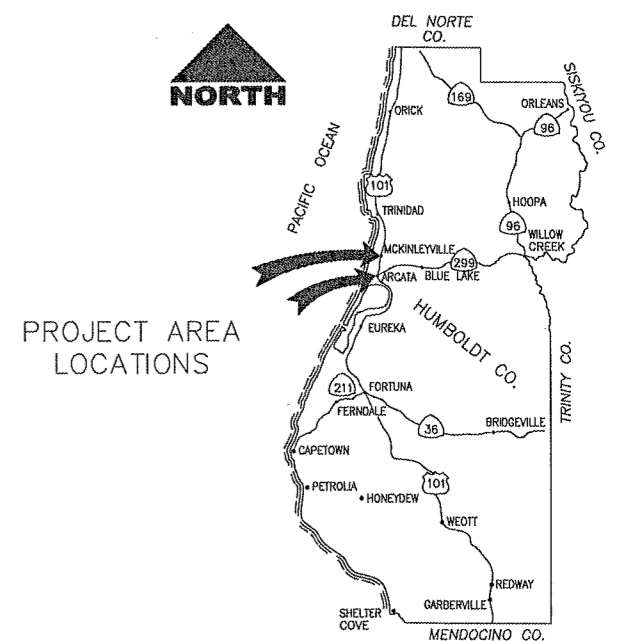

HUMBOLDT COUNTY
VICINITY MAP

NTS

STANDARD ABBREVIATIONS

AB	AGGREGATE BASE	FOC	FACE OF CURB	Rt	RIGHT
AC	ASPHALTIC CONCRETE	FOW	FACE OF WALK	R/W	RIGHT OF WAY
ADA	AMERICANS WITH DISABILITIES ACT	FT	FOOT (FEET)	S	SLOPE
AP	ANGLE POINT	G	GAS	SAW	SAWCUT LINE
APS	ACCESSIBLE PEDESTRIAN SIGNALS	GB	GRADE BREAK	SD	STORM DRAIN
BEG	BEGIN	GFL	GUTTER FLOWLINE	SDMH	STORM DRAIN MANHOLE
BLVD	BOULEVARD	GR	INLET GRATE	SF	SQUARE FOOT, OR FEET
BOC	BACK OF CURB	GV	GATE VALVE	SHT	SHEET
BOW	BACK OF WALK	HP	HIGH POINT	SS	SANITARY SEWER
BOV	BLOW OFF VALVE	IRR	IRRIGATION	SSCO	SANITARY SEWER CLEANOUT
CGS	CLEAR GROUND SPACE	LF	LINEAR FEET	SSMH	SANITARY SEWER MANHOLE
CONC	CONCRETE	LIP	LIP OF GUTTER PAN	STD	STANDARD
C&G	CURB AND GUTTER	Lt	LEFT	SW	SIDEWALK
CL	CENTERLINE OR CLASS	MAX	MAXIMUM	TBC	TOP BACK OF CURB
CLR	CLEAR	MH	MANHOLE	TBW	TOP BACK OF WALK
CG&SW	CURB, GUTTER & SIDEWALK	MIN	MINIMUM	TC	TOP OF CURB
CO	CLEANOUT	MOD	MODIFIED	TEL	TELECOMMUNICATION-TELEPHONE
CR	CURB RAMP	NTS	NOT TO SCALE	TEMP	TEMPORARY
CT	CALTRANS	OG	ORIGINAL GROUND	TFC	TOP FACE OF CURB
DI	DRAIN INLET	OH	OVERHEAD	TS	TRAFFIC SIGNAL
DWG	DRAWING	PB	PULL BOX	TYP	TYPICAL
DWS	DETECTABLE WARNING SURFACE	PED	PEDESTRIAN	UG	UNDERGROUND
DWY	DRIVEWAY	P/L	PROPERTY LINE	VAR	VARIES
EL/ELEV	ELEVATION	PP	POWER POLE	VG	VEE GUTTER/VALLEY GUTTER
EP	EDGE OF PAVEMENT	PPBP	PEDESTRIAN PUSH BUTTON POLE	VOL	VOLUME
EXIST	EXISTING	PVMT	PAVEMENT	W	WATER
FG	FINISHED GRADE	R	RADIUS	WM	WATER METER
FL	FLOWLINE	RPT	RADIAL POINT	WV	WATER VALVE
				XING	CROSSING



RECOMMENDED BY: Angi Sorenson 04/06/2023
DATE
ANGELIQUE H. SORENSEN
RCE 72951, EXP. 12/31/2024
COUNTY OF HUMBOLDT
PUBLIC WORKS



APPROVED BY: [Signature] 04/06/2023
DATE
TONY SEGHELLI
RCE 63714, EXP. 9/30/2024
COUNTY OF HUMBOLDT
PUBLIC WORKS DEPUTY DIRECTOR

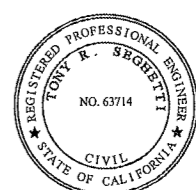

GENERAL NOTES:

- ALL CONSTRUCTION SHALL CONFORM TO THE COUNTY OF HUMBOLDT STANDARD SPECIFICATIONS, INCLUDING ALL OF THE MOST CURRENT UPDATES, ADDENDUMS AND MEMORANDUMS TO THEM.
- TWO WORKING DAYS PRIOR TO PROJECT STAKING, THE CONTRACTOR SHALL SUBMIT TO THE RESIDENT ENGINEER A COMPLETED CONSTRUCTION STAKING REQUEST FORM. CONTRACTOR R/W ACCESS: THE COUNTY SHALL PROVIDE PERMISSION TO ENTER WHERE WORK AND/OR CONSTRUCTION WILL BE DONE OUTSIDE OF THE EXISTING R/W.
- THE CONTRACTOR SHALL BE SOLELY RESPONSIBLE FOR FURNISHING, INSTALLING AND MAINTAINING ALL WARNING SIGNS AND DEVICES NECESSARY TO SAFEGUARD THE GENERAL PUBLIC AND THE WORK AND FOR PROVIDING PROPER AND SAFE ROUTING OF THE VEHICULAR AND PEDESTRIAN TRAFFIC DURING THE PERFORMANCE OF THE WORK. THIS REQUIREMENT SHALL APPLY CONTINUOUSLY AND SHALL NOT BE LIMITED TO WORKING HOURS. THE USE OF FLAGGERS, BARRICADES AND CONSTRUCTION SIGNING SHALL COMPLY WITH THE CURRENT EDITION OF THE CALIFORNIA MUTCD (2014) AND 2016 WATCHBOOK.
- THE CONTRACTOR IS RESPONSIBLE FOR DETERMINING THE LOCATION OF ALL EXISTING UTILITIES AS WELL AS PROTECTING AND REPAIRING ANY DAMAGE TO THEM. THE CONTRACTOR SHALL CONTACT UNDERGROUND SERVICE ALERT (1-800-642-2444) A MINIMUM OF TWO WORKING DAYS PRIOR TO WORK COMMENCEMENT.
- DEMOLITION OF EXISTING FEATURES SHALL BE LIMITED TO THE ITEMS SHOWN ON THE PLANS AND DESCRIBED IN THE SPECIAL PROVISIONS. IT SHALL BE THE CONTRACTOR'S RESPONSIBILITY TO REPAIR AND/OR REPLACE ALL EXISTING FEATURES DAMAGED BY THEIR OPERATIONS, AND AT THEIR OWN EXPENSE.
- THE CONTRACTOR SHALL POSSESS A CLASS "A" LICENSE, OR A COMBINATION OF CLASSES AS REQUIRED BY THE WORK CATEGORIES AND CLASSES OF WORK INCLUDED IN THIS CONTRACT.
- INCLUDED IN THE TRAFFIC CONTROL PLAN BUT NOT LIMITED TO: MAINTAINING TRAFFIC INCLUDES PEDESTRIANS, VEHICLES, & BICYCLES. WORK SHALL BE COMPLETED AND ALL TRAFFIC LANES SHALL BE RESTORED BY 4:30 PM EACH WORKDAY.
- ALL EXISTING CURB, GUTTER, AND SIDEWALK SHOWN TO BE REMOVED IS TO BE REMOVED OUT TO THE NEAREST EXPANSION JOINT OR SCORE MARK. DAMAGE TO EXISTING CURB, GUTTER AND SIDEWALK WHICH IS SHOWN ON THE PLANS TO REMAIN, SHALL BE REPAIRED AT THE CONTRACTOR'S EXPENSE. CONTRACTOR MUST BACKFILL ALL EXISTING, AND ANY NEWLY INSTALLED, SIDEWALK, CURB, RETAINING CURB, AND/OR CURB RAMP CONSTRUCTION ADJACENT TO EXISTING LANDSCAPING TO AVOID CREATING AN ADA TRIPPING HAZARD (VERTICAL DIFF. OF 1/4-INCH OR MORE).
- THE CONTRACTOR SHALL OBTAIN A PERMIT FROM THE DIVISION OF OCCUPATIONAL SAFETY & HEALTH [381 HEMSTED DRIVE, REDDING, CA 96002; PHONE (530) 224-4743] PRIOR TO ANY TRENCHING EXCAVATION 5 FEET OR MORE IN DEPTH. A HARD COPY OF THIS PERMIT MUST BE AVAILABLE ON THE CONSTRUCTION SITE AT ALL TIMES, AS NEEDED.
- THE CONTRACTOR SHALL BE COMPLETELY RESPONSIBLE FOR PRESERVING ALL EXISTING MONUMENTS WITHIN THE LIMITS OF THE CONTRACTOR'S WORK. CONTRACTOR SHALL COORDINATE WITH ENGINEER/SURVEYOR PRIOR TO DISTURBANCE OF EXISTING MONUMENTS, AND SHALL RESET MONUMENTS OR PROVIDE PERMANENT WITNESS MONUMENTS AND FILE DOCUMENTATION WITH THE COUNTY SURVEYOR PURSUANT TO BUSINESS AND PROFESSIONS CODE SECTION 8771.
- THE CONTRACTOR, SUBCONTRACTOR, AND/OR SURVEYOR SHALL NOT CUT PERMANENT CROSSES INTO EXISTING CONCRETE CURBS, GUTTERS OR SIDEWALKS. THE CONTRACTOR SHALL BE ASSESSED AN ADMINISTRATIVE PENALTY OF \$500 FOR EACH CROSS THAT IS CUT PERMANENTLY INTO EXISTING CONCRETE CURBS, GUTTERS AND SIDEWALKS.
- CONTRACTOR SHALL PROTECT PIPELINES, VAULTS, POLES, SIGNS, FENCING, MANHOLES, FIRE HYDRANTS, CONCRETE PADS, TEST STATIONS, VALVES, VENTS, AND OTHER APPURTENANCES WITHIN PROJECT WORK LIMITS. ANY DAMAGE TO COUNTY OR PRIVATE PROPERTY FACILITIES CAUSED BY THE CONTRACTOR, OR ASSOCIATED SUB-CONTRACTORS SHALL BE REPLACED/REPAIRED TO THEIR ORIGINAL CONDITION AT THE SOLE EXPENSE OF THE CONTRACTOR.
- DAMAGE TO THE ROADWAY OUTSIDE OF THE CURB RAMP CONSTRUCTION LIMITS IS NOT ACCEPTABLE. ANY DAMAGE ROADWAY CAUSED BY THE CONTRACTOR, OR ASSOCIATED SUB-CONTRACTORS SHALL BE REPAIRED TO ITS ORIGINAL CONDITION AT THE SOLE EXPENSE OF THE CONTRACTOR.

INDEX OF SHEETS

SHEET No.	DRAWING NAME
1	TITLE SHEET
2-4	LOCATION MAPS
5-7	QUANTITY TABLES
8-14	STANDARD DETAILS

ORIGINAL LOW BID PRICE	CONSTRUCTED BY	RESIDENT ENGINEER
	PROJECT COMPLETED	CONSTRUCTION COST \$

LEGEND:



COUNTY OF HUMBOLDT
DEPARTMENT OF PUBLIC WORKS

ENGINEERING DESIGN SECTION
 BAR BELOW IS ONE INCH ON ORIGINAL DRAWING
 IF NOT ONE INCH ON THIS SHEET, ADJUST SCALES ACCORDINGLY
 CONTRACT NO.: 325701
 DWG. FILE NAME: HUMCO DESIGN PHASE 3
 PLOT DATE: 03/20/23
 DESIGNED BY: WMH
 DRAWN BY: WMH
 REVIEWED BY: AHS
 APPROVED BY: TRS

COUNTY OF HUMBOLDT
DEPARTMENT OF PUBLIC WORKS
 ADA CURB RAMP IMPROVEMENTS (PHASE 3)
 Arcata

SHEET
2
OF
12

⊕ INTERSECTION LOCATION
 X-X-XX CURB RAMP ID LOCATION/DESIGNATION
 (SEE DETAILS FOR MORE INFO)

TOWN CODE
 INTERSECTION NUMBER
 CR LOCATION IDENTIFIER (#1 THROUGH #4)

TOWN NAME	TOWN CODE
EUREKA	1
ARCATA	2
McKINLEYVILLE	3
WESTHAVEN	4
ORICK	5
WILLOW CREEK	6
ORLEANS	7
BLUE LAKE	8
TABLE BLUFF	9
LOLETA	10
FERNDALE	11
ROHNERVILLE	12
FORTUNA	13
HYDEVILLE	14
SCOTIA	15
MIRANDA	16
REDWAY	17
GARBERVILLE	18

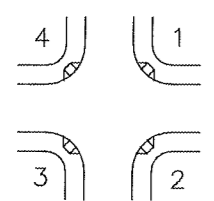

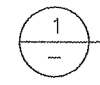

CR LOCATION INDEX

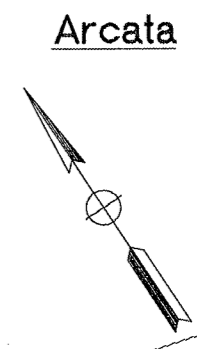
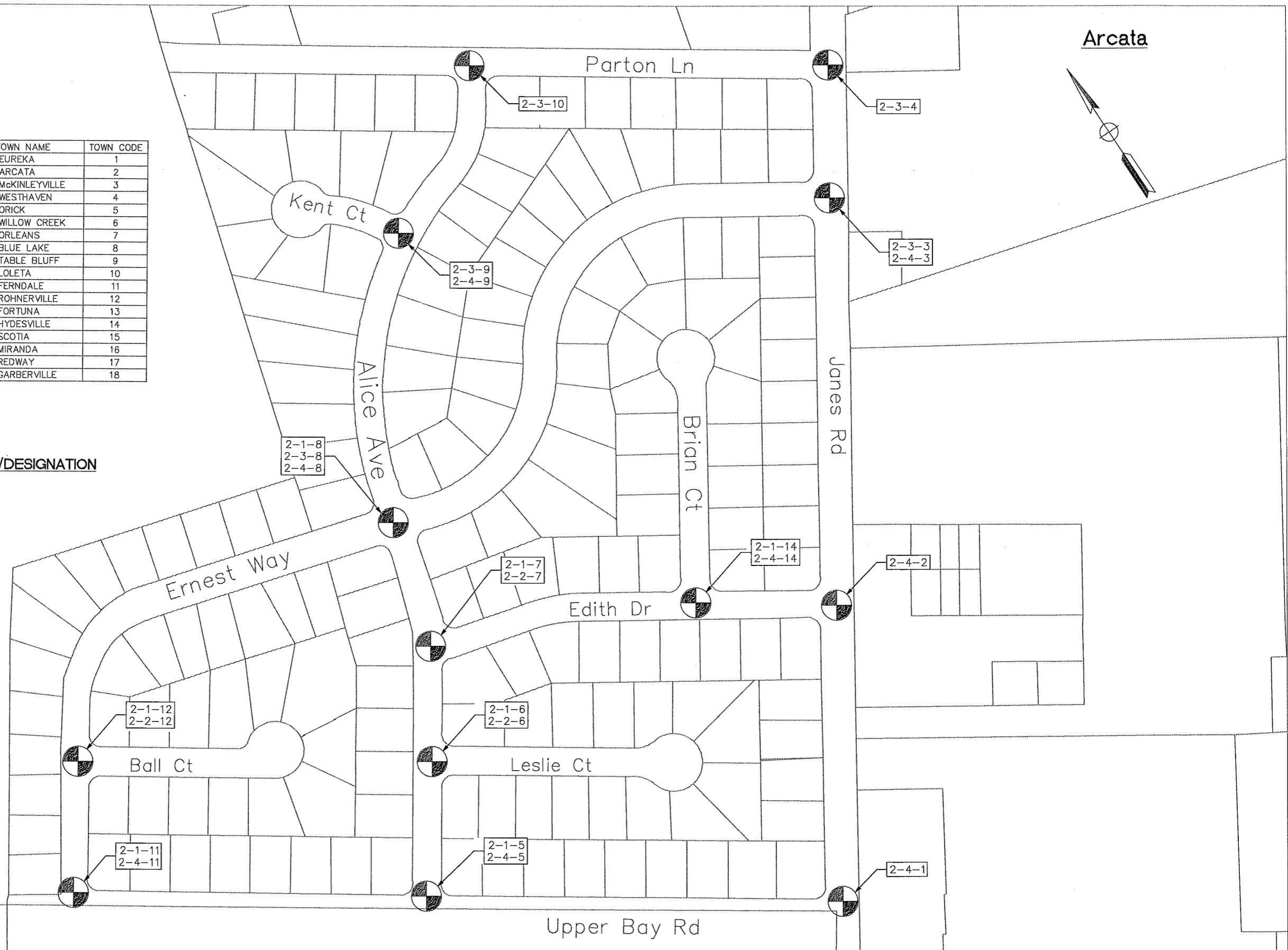

COUNTY CR ID LOCATION/DESIGNATION
NTS



LEGEND:

-  INTERSECTION LOCATION
-  CURB RAMP ID LOCATION/DESIGNATION (SEE DETAILS FOR MORE INFO)



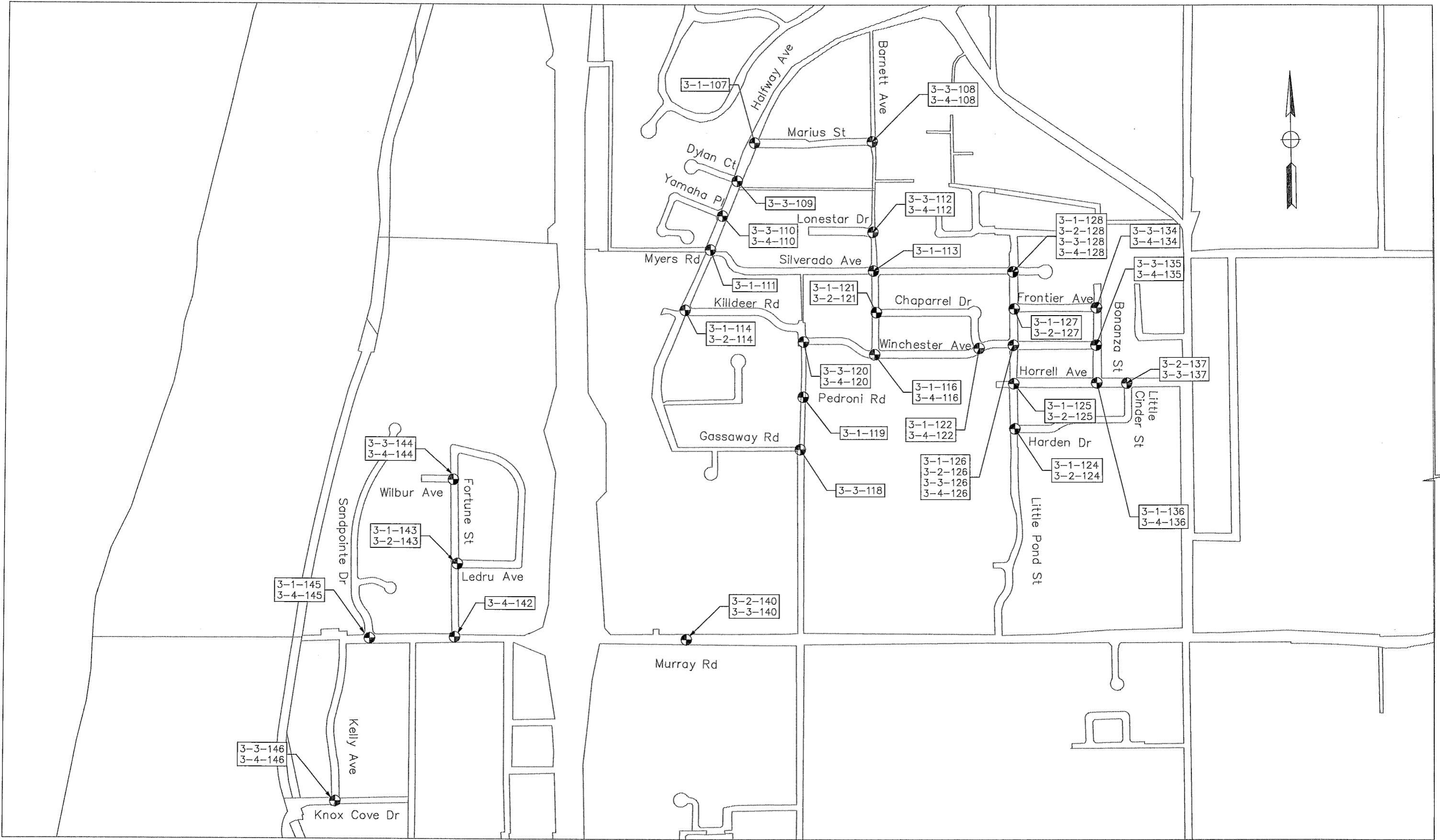

COUNTY OF HUMBOLDT
DEPARTMENT OF PUBLIC WORKS

BAR BELOW IS ONE INCH ON ORIGINAL DRAWING		ENGINEERING DESIGN SECTION		COUNTY OF HUMBOLDT DEPARTMENT OF PUBLIC WORKS		SHEET 3 OF 12
IF NOT ONE INCH ON THIS SHEET, ADJUST SCALES ACCORDINGLY		CONTRACT NO.: 325701	DESIGNED BY: WMH	ADA CURB RAMP IMPROVEMENTS (PHASE 3)		
		DWG. FILE NAME: HUMCO DESIGN PHASE 3	DRAWN BY: WMH	McKinleyville		
		PLOT DATE: 03/20/23	REVIEWED BY: AHS			
			APPROVED BY: TRS			



LEGEND:

-  INTERSECTION LOCATION
-  CURB RAMP ID LOCATION/DESIGNATION
(SEE DETAILS FOR MORE INFO)



COUNTY OF HUMBOLDT
DEPARTMENT OF PUBLIC WORKS

BAR BELOW IS ONE INCH
ON ORIGINAL DRAWING

ENGINEERING DESIGN SECTION

IF NOT ONE INCH ON
THIS SHEET, ADJUST
SCALES ACCORDINGLY

DESIGNED BY: HMH
 DRAWN BY: WMH
 CONTRACT NO.: 325701
 DWG. FILE NAME: HUMCO DESIGN PHASE 3
 PLOT DATE: 03/20/23

REVIEWED BY: AHS
 APPROVED BY: TRS

COUNTY OF HUMBOLDT
DEPARTMENT OF PUBLIC WORKS

ADA CURB RAMP IMPROVEMENTS (PHASE 3)

McKinleyville

SHEET
4
OF
12

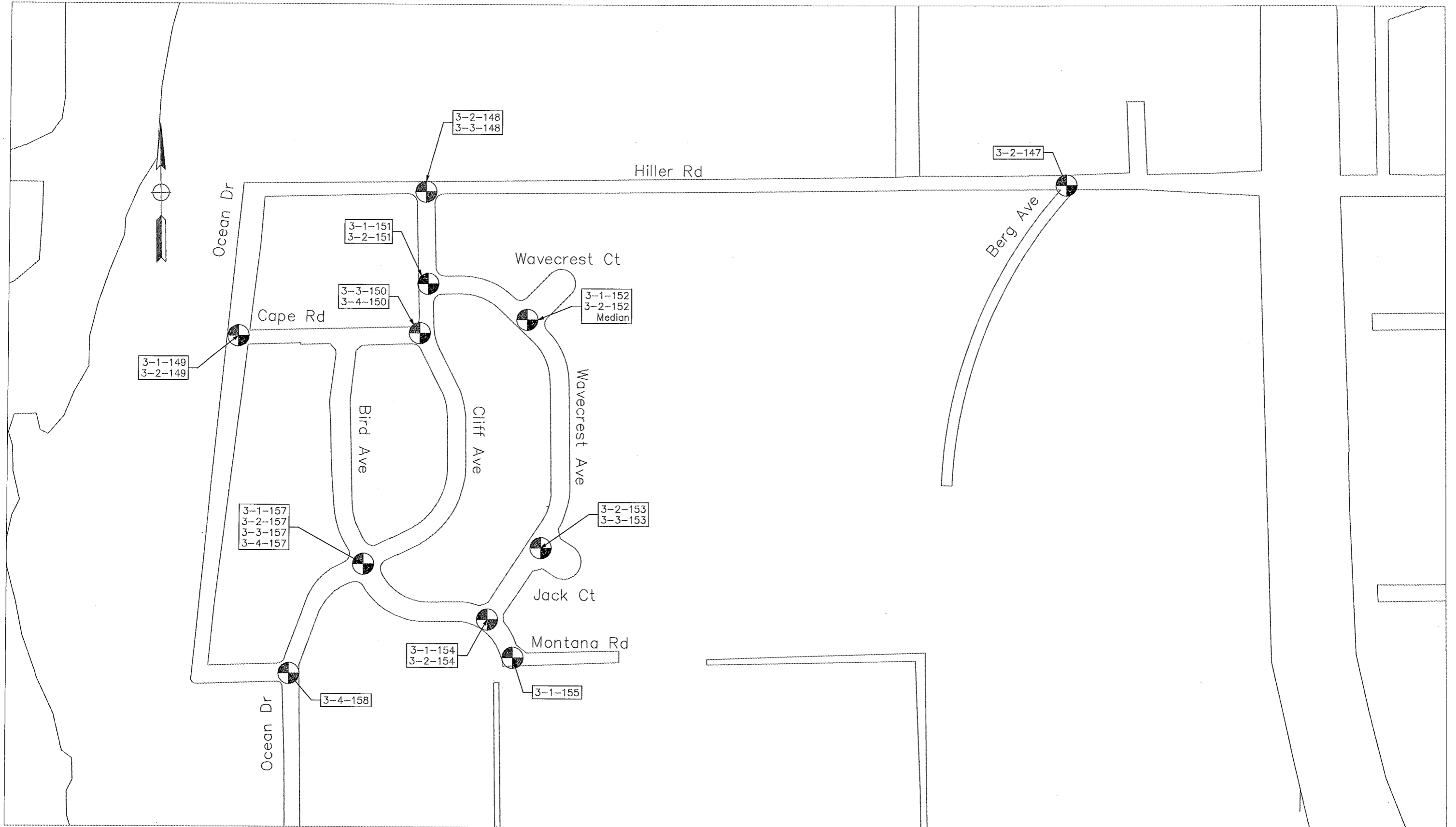

LEGEND:





COUNTY OF HUMBOLDT
DEPARTMENT OF PUBLIC WORKS

BAR BELOW IS ONE INCH ON ORIGINAL DRAWING	ENGINEERING DESIGN SECTION		COUNTY OF HUMBOLDT DEPARTMENT OF PUBLIC WORKS	SHEET 5 OF 12
	DESIGNED BY: WMH	CONTRACT NO.: 325701		
IF NOT ONE INCH ON THIS SHEET, ADJUST SCALES ACCORDINGLY	DWG. FILE NAME: HUNCO DESIGN PHASE 3	REVIEWED BY: AHS	ARCATA CURB RAMP QUANTITIES	
	PLOT DATE: 03/20/23	APPROVED BY: TRS		

- INTERSECTION LOCATION
- CURB RAMP ID LOCATION/DESIGNATION (SEE DETAILS FOR MORE INFO)

BID ITEM #				3	4	5	6	7	8	9	10	11-15	16	17	18
DPW PHASE 3 COUNT	CURB RAMP ID NO.	FIRST CROSS STREET ROAD NAME	SECOND CROSS STREET ROAD NAME	CONC REMOVAL (SQFT)	RELOCATE ROADSIDE SIGN (EA)	AB CL2 (CY)	HMA (TON)	ADJUST WM/WV/SSCO TO GRADE (EA)	REINFORCED C&G & X-GUTTER (CY)	CONC CURB/C&G (CY)	CONC SW (CY)	CURB RAMP TYPE	DWS (EA)	PLACE THERMO-PLASTIC MARKING (SF)	REMOVE THERMO-PLASTIC MARKING (SF)
1	2-4-1	Upper Bay Road	Janes Road	329	1	6.26	2.20	0	0.74	1.36	1.27	C	1	20	0
2	2-4-2	Edith Drive	Janes Road	385	1	7.21	2.58	1	0.74	1.48	1.61	C	1	40	24
3	2-3-3	Ernest Way	Janes Road	315	1	6.59	2.58	0	0.74	1.18	1.10	C	1	48	24
4	2-4-3	Ernest Way	Janes Road	280	0	4.97	2.11	0	0.74	0.59	0.55	C	1	32	16
5	2-3-4	Parton Lane	Janes Road	280	1	5.85	2.11	0	0.74	1.18	1.10	C	1	10	0
6	2-1-5	Upper Bay Road	Alice Avenue	280	0	5.85	2.11	0	0.74	1.18	1.10	C	1	0	0
7	2-4-5	Upper Bay Road	Alice Avenue	358	1	6.97	2.81	0	0.74	1.18	1.10	C	1	10	0
8	2-1-6	Leslie Court	Alice Avenue	293	1	5.78	2.34	1	0.74	0.89	0.83	C	1	0	0
9	2-2-6	Leslie Court	Alice Avenue	332	0	6.49	2.62	1	0.74	1.06	0.99	C	1	0	0
10	2-1-7	Edith Drive	Alice Avenue	371	1	6.85	2.91	0	0.74	1.00	0.94	C	1	0	0
11	2-2-7	Edith Drive	Alice Avenue	306	0	6.11	2.44	0	0.74	1.00	0.94	C	1	0	0
12	2-1-8	Ernest Way	Alice Avenue	338	0	6.48	2.67	0	0.74	1.00	0.94	C	1	42	42
13	2-3-8	Ernest Way	Alice Avenue	319	0	5.99	2.53	1	0.74	0.83	0.77	C	1	0	0
14	2-4-8	Ernest Way	Alice Avenue	293	1	5.34	2.34	0	0.74	0.59	0.55	C	1	42	42
15	2-3-9	Kent Court	Alice Avenue	345	1	7.75	2.72	0	1.85	1.06	0.99	C	1	0	0
16	2-4-9	Kent Court	Alice Avenue	493	0	9.05	2.81	0	3.70	0.59	0.55	C	1	0	0
17	2-3-10	Parton Lane	Alice Avenue	293	0	5.34	2.34	0	0.74	0.59	0.55	C	1	0	0
18	2-1-11	Upper Bay Road	Ernest Way	325	0	6.15	2.58	1	0.74	0.89	0.83	C	1	0	0
19	2-4-11	Upper Bay Road	Ernest Way	260	1	4.53	2.11	0	0.74	0.30	0.28	C	1	10	0
20	2-1-12	Ernest Way	Ball Court	260	1	4.53	2.11	0	0.74	0.30	0.28	C	1	0	0
21	2-2-12	Ernest Way	Ball Court	293	0	5.34	2.34	0	0.74	0.59	0.55	C	1	0	0
22	2-1-14	Edith Drive	Brian Court	371	0	8.90	2.81	1	2.50	1.30	1.21	C	1	0	0
23	2-4-14	Edith Drive	Brian Court	312	1	6.83	2.58	1	1.85	0.59	0.55	C	1	0	0
ARCATA BID ITEM SUMMATIONS				7425	12	145	57	7	24	21	20	Type C= 23 EA	23	254	148

LEGEND:

-  INTERSECTION LOCATION
-  CURB RAMP ID LOCATION/DESIGNATION (SEE DETAILS FOR MORE INFO)



COUNTY OF HUMBOLDT
DEPARTMENT OF PUBLIC WORKS

BAR BELOW IS ONE INCH ON ORIGINAL DRAWING

IF NOT ONE INCH ON THIS SHEET, ADJUST SCALES ACCORDINGLY



ENGINEERING DESIGN SECTION
DESIGNED BY: WMH
DRAWN BY: WMH
CONTRACT NO.: 325701
DWG. FILE NAME: HUMCO DESIGN PHASE 3
PLOT DATE: 03/20/23
REVIEWED BY: AHS
APPROVED BY: TRS

COUNTY OF HUMBOLDT
DEPARTMENT OF PUBLIC WORKS
ADA CURB RAMP IMPROVEMENTS (PHASE 3)
MCKINLEYVILLE CURB RAMP QUANTITIES

SHEET
6
OF
12

BID ITEM #				3	4	5	6	7	8	9	10	11-15	16	17	18
DPW Int. Priority Number	CURB RAMP ID NO.	FIRST CROSS STREET ROAD NAME	SECOND CROSS STREET ROAD NAME	CONC REMOVAL (SQFT)	RELOCATE ROADSIDE SIGN (EA)	AB CL2 (CY)	HMA (TON)	ADJUST WM/WV/SSCO TO GRADE (EA)	REINFORCED C&G & X-GUTTER (CY)	CONC CURB/ C&G (CY)	CONC SW (CY)	CURB RAMP TYPE	DWS (EA)	THERMO-PLASTIC MARKING (SF)	THERMO-PLASTIC MARKING (SF)
24	3-1-107	Halfway Avenue	Marius Street	458	1	4.59	1.41	0	1.48	0.59	0.55	C	1	32	32
25	3-3-108	Barnett Avenue	Marius Street	295	1	6.49	2.34	1	0.74	1.36	1.27	A	1	45	45
26	3-4-108	Barnett Avenue	Marius Street	287	0	6.22	2.34	0	0.74	1.18	1.10	A	1	0	0
27	3-3-109	Dylan Court	Halfway Avenue	55	0	3.09	1.17	0	0.44	1.00	0.00	Repair type A	0	0	0
28	3-3-110	Yamaha Place	Halfway Avenue	44	0	2.51	0.94	0	0.44	0.74	0.00	Repair type A	0	0	0
29	3-4-110	Yamaha Place	Halfway Avenue	297	0	3.52	1.41	0	0.74	0.00	0.72	A	1	0	0
30	3-1-111	Myers Road	Halfway Avenue	354	1	7.18	3.28	0	1.20	0.41	0.58	C	1	5	5
31	3-3-112	Barnett Avenue	Lonestar Drive	355	1	6.24	2.58	0	0.74	0.94	0.88	B	1	6	6
32	3-4-112	Barnett Avenue	Lonestar Drive	479	0	7.49	2.81	0	0.74	1.53	1.43	B	1	0	0
33	3-1-113	Barnett Avenue	Silverado Avenue	338	1	3.98	1.87	0	0.74	0.18	0.17	A	1	0	0
34	3-1-114	Halfway Avenue	Killdeer Road	308	1	5.78	2.34	0	0.74	0.89	0.83	C	1	10	10
35	3-2-114	Halfway Avenue	Killdeer Road	266	0	5.41	2.11	0	0.74	0.89	0.83	C	1	0	0
36	3-1-116	Barnett Avenue	Winchester Avenue	310	0	5.14	2.34	0	0.74	0.35	0.53	C	1	0	0
37	3-4-116	Barnett Avenue	Winchester Avenue	280	1	5.41	2.11	0	0.74	0.89	0.83	C	1	52	52
38	3-3-118	Mckinleyville Avenue	Gassaway Road	170	0	5.59	2.50	0	0.74	0.59	0.55	A	1	0	0
39	3-1-119	Mckinleyville Avenue	Pedroni Road	75	0	3.17	1.03	0	0.59	0.94	0.27	Repair type A	1	0	0
40	3-3-120	Mckinleyville Avenue	Allie Court	87	0	1.45	0.00	0	0.00	0.83	1.06	Repair type A	1	0	0
41	3-4-120	Mckinleyville Avenue	Allie Court	155	0	3.64	0.00	0	1.56	0.83	1.90	Repair type A	1	0	0
42	3-1-121	Barnett Avenue	Chaparrel Drive	324	1	5.21	2.11	0	0.74	0.62	0.84	A	1	0	0
43	3-2-121	Barnett Avenue	Chaparrel Drive	249	0	3.64	1.64	0	0.74	0.00	0.39	C	1	0	0
44	3-1-122	Winchester Avenue	Chaparrel Drive	280	0	5.34	2.34	0	0.74	0.59	0.55	C	1	0	0
45	3-4-122	Winchester Avenue	Chaparrel Drive	252	1	4.40	1.97	0	0.74	0.35	0.33	C	1	0	0
46	3-1-124	Little Pond Street	Harden Drive	371	1	6.66	2.34	0	0.74	1.48	1.38	C	1	10	10
47	3-2-124	Little Pond Street	Harden Drive	280	0	5.34	2.34	0	0.74	0.59	0.55	C	1	0	0
48	3-1-125	Little Pond Street	Horrell Avenue	294	1	5.61	2.34	0	0.74	0.77	0.72	C	1	10	10
49	3-2-125	Little Pond Street	Horrell Avenue	317	1	5.84	2.34	0	0.74	0.83	0.97	C	1	47	42
50	3-1-126	Little Pond Street	Winchester Avenue	384	1	5.40	2.34	0	0.74	0.53	0.69	C	1	42	42
51	3-2-126	Little Pond Street	Winchester Avenue	340	0	4.16	1.87	0	0.74	0.30	0.28	C	1	0	0
52	3-3-126	Little Pond Street	Winchester Avenue	377	1	4.66	1.87	0	0.74	0.53	0.69	C	1	37	37
53	3-4-126	Little Pond Street	Winchester Avenue	391	0	4.75	1.87	0	0.74	0.59	0.75	C	1	0	0
54	3-1-127	Little Pond Street	Frontier Avenue	317	1	5.34	2.58	0	0.74	0.24	0.42	C	1	52	52
55	3-2-127	Little Pond Street	Frontier Avenue	338	0	5.95	2.58	0	0.74	0.65	0.80	C	1	0	0
56	3-1-128	Little Pond Street	Silverado Avenue	444	1	5.74	2.50	0	1.33	0.30	0.28	C	1	42	42
57	3-2-128	Little Pond Street	Silverado Avenue	465	0	6.18	2.50	0	1.33	0.59	0.55	C	1	0	0
58	3-3-128	Little Pond Street	Silverado Avenue	451	1	4.50	1.72	0	1.33	0.30	0.28	C	1	47	47
59	3-4-128	Little Pond Street	Silverado Avenue	423	0	5.32	2.34	0	1.33	0.18	0.17	C	1	0	0
60	3-3-134	Frontier Avenue	Bonanza Street	280	1	4.81	2.34	0	0.74	0.24	0.22	C	1	10	10
61	3-4-134	Frontier Avenue	Bonanza Street	310	0	5.23	2.34	0	0.74	0.41	0.58	C	1	0	0
62	3-3-135	Winchester Avenue	Bonanza Street	280	1	4.81	2.34	0	0.74	0.24	0.22	C	1	42	42
63	3-4-135	Winchester Avenue	Bonanza Street	308	0	5.71	2.58	0	0.74	0.59	0.55	C	1	0	0
64	3-1-136	Horrell Avenue	Bonanza Street	416	0	4.69	1.56	0	1.33	0.59	0.55	C	1	0	0

LEGEND:

-  INTERSECTION LOCATION
-  CURB RAMP ID LOCATION/DESIGNATION (SEE DETAILS FOR MORE INFO)



COUNTY OF HUMBOLDT
DEPARTMENT OF PUBLIC WORKS

ENGINEERING DESIGN SECTION

DESIGNED BY: WMH
DRAWN BY: WMH
REVIEWED BY: AHS
APPROVED BY: TRS

CONTRACT NO.: 325701
DWG. FILE NAME: HUMCO DESIGN PHASE 3
PLOT DATE: 03/20/23

COUNTY OF HUMBOLDT
DEPARTMENT OF PUBLIC WORKS

ADA CURB RAMP IMPROVEMENTS (PHASE 3)

MCKINLEYVILLE CURB RAMP QUANTITIES

BID ITEM #				3	4	5	6	7	8	9	10	11-15	16	17	18
DPW Int. Priority Number	CURB RAMP ID NO.	FIRST CROSS STREET ROAD NAME	SECOND CROSS STREET ROAD NAME	CONC REMOVAL (SQFT)	RELOCATE ROADSIDE SIGN (EA)	AB CL2 (CY)	HMA (TON)	ADJUST WM/WV/SSCO TO GRADE (EA)	REINFORCED C&G & X-GUTTER (CY)	CONC CURB/ C&G (CY)	CONC SW (CY)	CURB RAMP TYPE	DWS (EA)	THERMO-PLASTIC MARKING (SF)	THERMO-PLASTIC MARKING (SF)
65	3-4-136	Horrell Avenue	Bonanza Street	430	1	4.43	1.56	0	1.33	0.41	0.39	C	1	42	42
66	3-2-137	Horrell Avenue	Little Cinder Street	343	1	6.68	2.58	0	0.74	1.24	1.16	C	1	0	0
67	3-3-137	Horrell Avenue	Little Cinder Street	231	0	4.25	1.87	0	0.74	0.35	0.33	C	1	0	0
68	3-2-140	Murray Road	Pine Avenue	298	2	6.42	2.66	2	0.74	0.89	1.01	A	1	0	0
69	3-3-140	Murray Road	Pine Avenue	239	0	5.04	2.45	0	0.74	0.24	0.29	A	1	0	0
70	3-4-142	Murray Road	Fortune Street	289	2	4.44	2.03	0	0.74	0.24	0.39	C	1	42	42
71	3-1-143	Ledru Avenue	Fortune Street	536	1	10.64	3.28	0	4.81	0.41	0.39	C	1	42	38
72	3-2-143	Ledru Avenue	Fortune Street	571	0	10.16	3.28	0	4.07	0.59	0.55	C	1	0	0
73	3-3-144	Wilbur Avenue	Fortune Street	501	1	9.42	2.81	1	4.07	0.59	0.55	C	1	0	0
74	3-4-144	Wilbur Avenue	Fortune Street	501	0	9.42	2.81	1	4.07	0.59	0.55	C	1	0	0
75	3-1-145	Murray Road	Sandpointe Drive	233	0	2.43	0.84	0	0.74	0.00	0.46	F	1	0	0
76	3-4-145	Murray Road	Sandpointe Drive	233	0	2.43	0.84	0	0.74	0.00	0.46	F	1	0	0
77	3-3-146	Knox Cove Avenue	Kelly Avenue	329	1	5.79	2.34	0	0.74	0.89	0.83	C	1	42	42
78	3-4-146	Knox Cove Avenue	Kelly Avenue	329	0	5.79	2.34	0	0.74	0.89	0.83	C	1	0	0
79	3-2-147	Hiller Road	Berg Avenue	194	1	5.30	2.34	0	0.74	0.59	0.49	CM	1	0	0
80	3-2-148	Hiller Road	Cliff Avenue	194	1	5.30	2.34	0	0.74	0.59	0.49	C	1	0	0
81	3-3-148	Hiller Road	Cliff Avenue	195	0	6.24	2.34	0	0.74	1.26	1.04	C	1	0	0
82	3-1-149	Cape Road	Ocean Drive	323	1	5.34	2.34	0	0.74	0.59	0.55	A	1	0	0
83	3-2-149	Cape Road	Ocean Drive	239	0	4.09	1.41	0	0.74	0.65	0.80	C	1	0	0
84	3-3-150	Cape Road	Cliff Avenue	280	1	6.22	2.34	0	0.74	1.18	1.10	C	1	0	0
85	3-4-150	Cape Road	Cliff Avenue	331	0	6.92	2.58	0	0.74	1.30	1.41	C	1	0	0
86	3-1-151	Wavecrest Avenue	Cliff Avenue	483	1	7.73	2.16	0	2.55	1.18	1.10	C	1	40	36
87	3-2-151	Wavecrest Avenue	Cliff Avenue	418	0	14.50	5.31	0	4.31	1.18	1.10	C	1	0	0
88	3-1-152	Wavecrest Avenue	Wavecrest Court	215	0	5.70	2.02	0	0.74	1.18	1.10	C	1	0	0
89	3-2-152	Wavecrest Avenue	Wavecrest Court	215	0	5.70	2.02	0	0.74	1.18	1.10	C	1	0	0
90	Island	Wavecrest Avenue	Wavecrest Court	110	1	10.39	2.34	0	0.00	4.13	2.08	NA	2	0	0
91	3-2-153	Wavecrest Avenue	Jack Court	276	0	4.51	1.97	0	0.74	0.24	0.61	A	1	0	0
92	3-3-153	Wavecrest Avenue	Jack Court	294	0	5.13	2.16	0	0.74	0.65	0.61	A	1	0	0
93	3-1-154	Wavecrest Avenue	Bird Avenue	311	1	5.50	2.34	0	0.74	0.41	0.94	A	1	0	0
94	3-2-154	Wavecrest Avenue	Bird Avenue	309	0	5.47	2.34	0	0.74	0.59	0.72	A	1	0	0
95	3-1-155	Montana Road	Bird Avenue	296	1	5.32	2.34	0	0.74	0.35	0.77	A	1	0	0
96	3-1-157	Cliff Avenue	Bird Avenue	294	1	5.34	2.34	0	0.74	0.59	0.55	C	1	0	0
97	3-2-157	Cliff Avenue	Bird Avenue	375	1	5.99	2.58	0	0.74	0.59	0.92	C	1	45	45
98	3-3-157	Cliff Avenue	Bird Avenue	350	1	5.97	2.58	0	0.74	0.65	0.83	C	1	0	0
99	3-4-157	Cliff Avenue	Bird Avenue	371	1	6.78	2.81	0	0.74	0.94	1.10	C	1	45	45
100	3-4-158	Cliff Avenue	Ocean Drive	271	1	5.17	2.34	0	0.74	0.47	0.44	C	1	0	0
MCKINLEYVILLE BID ITEM SUMMATIONS				23908	41	432	168	5	80	53	54	Type A= 14 EA Type B= 2 EA Type C= 52 EA Type CM= 1 EA Type F= 2 EA Repairs= 5 EA Island= 1 EA	76	787	774
BID ITEM NUMBER				3	4	5	6	7	8	9	10	11-15	16	17	18
BID ITEM TYPE				CONC REMOVAL (SQFT)	RELOCATE ROADSIDE SIGN (EA)	AB CL2 (CY)	HMA (TON)	ADJUST WM/WV/SSCO TO GRADE (EA)	REINFORCED C&G & X-GUTTER (CY)	CONC CURB/ C&G (CY)	CONC SW (CY)	CURB RAMP TYPE	DWS (EA)	THERMO-PLASTIC MARKING (SF)	THERMO-PLASTIC MARKING (SF)
BID ITEM TOTAL QUANTITIES				31333	53	577	225	12	104	74	74	Type A= 14 EA Type B= 2 EA Type C= 75 EA Type CM= 2 EA Type F= 2 EA Repairs= 5 EA Island= 1 EA	99	1041	922



COUNTY OF HUMBOLDT
DEPARTMENT OF PUBLIC WORKS

BAR BELOW IS ONE INCH ON ORIGINAL DRAWING IF NOT ONE INCH ON THIS SHEET, ADJUST SCALES ACCORDINGLY	ENGINEERING DESIGN SECTION		COUNTY OF HUMBOLDT DEPARTMENT OF PUBLIC WORKS	SHEET 8 OF 12
	CONTRACT NO.: 325701	DESIGNED BY: WMH	ADA CURB RAMP IMPROVEMENTS (PHASE 3)	
	DWG. FILE NAME: HUMBDO DESIGN PHASE 3	DRAWN BY: WMH	STANDARD DETAILS	
	PLOT DATE: 03/20/23	REVIEWED BY: AHS		
		APPROVED BY: TRS		

CONTRACTOR NOTES

CURB & GUTTER

- FORMS SHALL BE CAREFULLY SET TO ALIGNMENT AND GRADE AND SHALL CONFORM TO THE DIMENSIONS AS SHOWN ON THESE PLANS. FORMS SHALL BE HELD RIGIDLY IN PLACE BY STAKES, CLAMPS, SPREADERS, AND BRACES SHALL BE USED WHERE REQUIRED, IN ADDITION, TO ENSURE RIGIDITY IN THE FORM.
- PRIOR TO THE REMOVAL OF THE FORMS, THE SURFACE SHALL BE FINISHED TRUE TO GRADE BY MEANS OF A STRAIGHT EDGE FLOAT, NOT LESS THAN 10 FEET IN LENGTH, OPERATED LONGITUDINALLY OVER THE SURFACE OF THE CONCRETE. FORM CLAMPS SHALL BE SO CONSTRUCTED AS NOT TO INTERFERE WITH THE OPERATION OF THE FLOAT.
- IMMEDIATELY AFTER REMOVING THE FRONT CURB FORMS, THE FACE OF THE CURB SHALL BE TROWELED SMOOTH TO A DEPTH OF NOT LESS THAN 0.17 FEET (2-1/16 INCHES) BELOW, OR TO THE FLOW LINE OF INTEGRAL CURB AND GUTTER, AND THEN FINISHED WITH A STEEL TROWEL. THE TOP SHALL BE FINISHED AND THE FRONT AND BACK EDGES ROUNDED AS SHOWN HEREON. AFTER THE FACE OF THE CURB HAS BEEN TROWELED SMOOTH, IT SHALL BE GIVEN A FINAL FINE BRUSH FINISH WITH BRUSH STROKES PARALLEL TO THE LINE OF THE CURB.
- THE TOP AND FACE OF THE FINISHED CURB SHALL BE TRUE AND STRAIGHT AND THE TOP SURFACE OF CURBS SHALL BE OF UNIFORM WIDTH, FREE FROM HUMPS, SAGS, OR OTHER NOTICEABLE IRREGULARITIES.
- WHEN A STRAIGHT EDGE 10 FEET LONG IS LAID ON THE TOP FACE OF THE CURB OR ON THE SURFACE OF GUTTERS, THE SURFACE SHALL NOT VARY MORE THAN 0.01 FOOT (1/8 INCH) FROM THE EDGE OF THE STRAIGHT EDGE, EXCEPT AT GRADE CHANGES OR CURVES.
- CURB DRAINS THROUGH EXISTING CURB FACE SHALL BE CORED -OR- REMOVE CURB AND GUTTER FOR A MINIMUM WIDTH OF 1 FOOT, OR 6 INCHES ON EACH SIDE OF THE DRAIN, WHICHEVER IS GREATER. ENGINEER MUST APPROVE THIS WORK IN ADVANCE OF ANY DEMO TO BE STARTED.

- 4' WIDE SIDEWALK REQUIRES 5'x5' PASSING AREA(S) THAT SHALL BE SPACED NO MORE THAN 200' APART.
- NOTE: SIDEWALK WIDTHS DO NOT INCLUDE CURBS. SEE CALTRANS HIGHWAY DESIGN MANUAL SECTION 105.1
- MAXIMUM SIDEWALK CROSS SLOPE IS 2%. THE COUNTY PUBLIC WORKS DEPARTMENT RECOMMENDS THAT FORMS BE BUILT TO 1.5% TO ENSURE THAT CROSS SLOPE DOES NOT EXCEED 2%. MAXIMUM SIDEWALK RUNNING SLOPE IS 5%. THE COUNTY PUBLIC WORKS DEPARTMENT RECOMMENDS THAT FORMS BE BUILT TO 4.5% TO ENSURE THAT SLOPE DOES NOT EXCEED 5%.
 - THE REPAIR AND MAINTENANCE OF SIDEWALKS IS THE RESPONSIBILITY OF THE ADJOINING LOT OWNER. SEE RESOLUTION NO. 97-31 ADOPTED BY THE BOARD OF SUPERVISORS ON 03/04/1997.
 - LIMITS OF DEMOLITION ARE FROM CONFORM TO CONFORM WHERE THERE IS EXISTING SIDEWALK. IF SIDEWALK IS NOT CONTIGUOUS, THEN THE DEMOLITION LIMIT GOES TO THE END OF EXISTING, OR NEW, SIDEWALK. REMOVAL FROM BOW TO THE SAWCUT LINE(S) DELINEATE PERIMETER LIMITS BEYOND THE SIDEWALK (CURB, GUTTER, AND HMA AS WELL AS WALK PATH).

LANDSCAPING

- RECOMMENDED WIDTH OF LANDSCAPE STRIP IS 5 FEET. MINIMUM WIDTH OF LANDSCAPE STRIP IS 3 FEET. MAINTENANCE OF LANDSCAPE AREAS BETWEEN THE CURB AND THE SIDEWALK (PARKWAYS) IS THE RESPONSIBILITY OF THE ADJACENT LOT- OWNER.
- STREET TREES REQUIRE A ROOT BARRIER TO PREVENT DAMAGE TO THE CURB, SIDEWALK AND ROAD. CONTACT THE COUNTY PUBLIC WORKS DEPARTMENT FOR TREE SPECIES RECOMMENDATION AND GUIDELINES.
- LANDSCAPING MUST COMPLY WITH THE COUNTY VISIBILITY ORDINANCE (COUNTY CODE SECTION 341-1 ET SEQ.). THE DEPARTMENT RECOMMENDS LOW HEIGHT VEGETATION IN ALL LANDSCAPE STRIPS (LESS THAN 12" TALL).
- BACKFILL TRENCHES, HOLES, DEPRESSIONS AND PITS CAUSED BY PERFORMING WORK ON AN EXISTING FACILITY. IN AN UNSURFACED AREA BACKFILL WITH EMBANKMENT MATERIAL UNDER SECTION 19. IN A SURFACED AREA, BACKFILL WITH MATERIAL EQUAL TO OR BETTER THAN THE SURROUNDING MATERIAL. GRADE BACKFILLED AREAS TO DRAIN AND BLEND IN WITH THE SURROUNDING AREA. BACKFILL WITHIN TWO WEEKS OF CONSTRUCTION.

CURB RAMP

- ACTUAL ADA REQUIREMENTS ARE REFLECTED ON THESE SHEETS MAY BE DIFFERENT FROM THE REQUIREMENTS SHOWN ON CALTRANS REVISED STANDARD PLAN RSP A88A DATED 11/18/2022 WHICH WAS DEVELOPED FROM DESIGN INFORMATION BULLETIN (DIB) 82-06 DATED 11/18/2022. SECTION 4.3 (DESIGN STANDARDS) OF THE DIB STATES THAT THE REVISED STANDARD PLAN CONTAINS CONSERVATIVE SLOPES AND WIDTHS THAT ARE DIFFERENT FROM THE ACTUAL ADA SPECIFICATIONS CONTAINED IN THE DIB. THE ACTUAL ADA REQUIREMENTS ARE SPECIFIED IN SECTION 4.3.8 (CURB RAMPS) AND SECTION 4.3.5 (CROSS SLOPES) OF THE DIB.
- MAXIMUM CURB RAMP GRADE IS 8.33%. THE DEPARTMENT RECOMMENDS THAT FORMS BE BUILT TO 7.5% TO ENSURE THAT THE RAMP GRADE DOES NOT EXCEED 8.33%.
- LANDINGS ARE PIVOT POINTS. GRADES AT THE TOP AND BOTTOM OF CURB RAMP LANDINGS ARE 2% MAXIMUM. THE DEPARTMENT RECOMMENDS THAT FORMS BE BUILT TO 1.3% TO ENSURE THAT THE CROSS SLOPE DOES NOT EXCEED 2%.
- CURB RAMPS SHALL HAVE A RUNNING SLOPE NOT STEEPER THAN 1V:12H (8.3%) MAXIMUM BUT SHALL NOT REQUIRE THE RAMP LENGTH TO EXCEED 15 FEET.

SIDEWALKS

- THE SURFACE OF SIDEWALKS SHALL BE MARKED INTO RECTANGLES OF NOT LESS THAN 12 SQUARE FEET NOR MORE THAN 20 SQUARE FEET WITH A SCORING TOOL WHICH WILL LEAVE THE EDGES ROUNDED. WEAKENED PLANE JOINTS SHALL BE CONSTRUCTED AT 20 FOOT INTERVALS. THE JOINTS SHALL BE CONSTRUCTED TO A MINIMUM DEPTH OF ONE INCH BY SCORING WITH A TOOL WHICH WILL LEAVE THE CORNERS ROUNDED AND ENSURE A FREE MOVEMENT OF THE CONCRETE AT THE JOINT.
- SURFACES SHALL BE BROOM FINISHED. SURFACES TO BE USED BY PEDESTRIAN TRAFFIC SHALL BE BROOMED TRANSVERSELY TO THE LINE OF TRAFFIC.
- THE SURFACE SHALL NOT VARY MORE THAN 0.02 FEET (1/4-INCH) FROM A 10-FOOT STRAIGHT EDGE, EXCEPT AT GRADE CHANGES, AND THE FINISHED SURFACE SHALL BE FREE FROM BLEMISHES.
- REPAIRS SHALL BE MADE BY REMOVING AND REPLACING THE ENTIRE UNIT BETWEEN SCORING LINES OR JOINTS.
- OBSTRUCTIONS: PREFERENCE IS TO MAINTAIN A CLEARANCE OF 4 FEET AROUND OBSTRUCTIONS SUCH AS UTILITY POLES, FIRE HYDRANTS, ETC. [REFERENCE: CBC 11B-403.5.1; 28 CFR PART 36 SEC 4.3.3]. A MINIMUM CLEARANCE OF 36-INCHES MUST BE MAINTAINED PER DOJ-ADA 2010 STANDARDS.
- SW WIDTHS VARY BASED UPON ROAD RIGHT OF WAY. TYPICAL COUNTY SW WIDTHS ARE AS FOLLOWS:
 WIDTH = 5' FOR RIGHT OF WAYS 50 FEET OR LESS
 WIDTH = 6' FOR RIGHT OF WAYS GREATER THAN 50 FEET
 WIDTH = 4' ONLY FOR SPECIAL CIRCUMSTANCES:
 THE DEPARTMENT MAY ALLOW 4' SIDEWALK TO BE CONSTRUCTED AS INFILL BETWEEN TWO EXISTING STRETCHES OF 4' WIDE SIDEWALK. CONTRACTOR SHALL NOTIFY ENGINEER IN ADVANCE OF THIS INFILL-TYPE SIDEWALK WORK BEING PROPOSED.

SIDEWALK WIDTH MAY BE REDUCED TO 4' BEHIND DRIVEWAY APRONS.

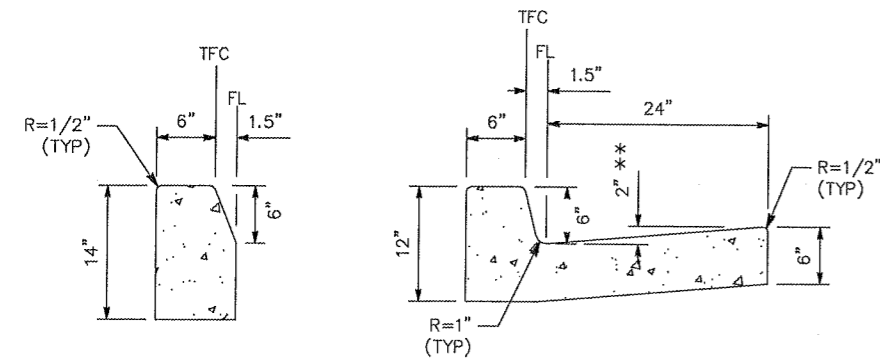

CALTRANS TYPE A1-6

CALTRANS TYPE A2-6

6" HIGH CURBS

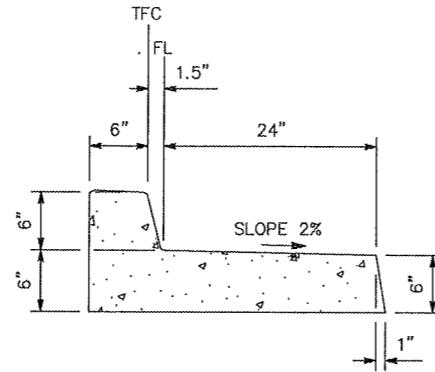

APWA TYPE A3-6
(SPILL GUTTER)

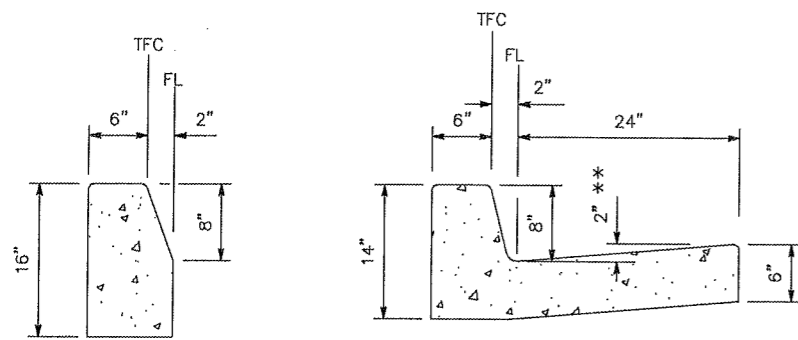

CALTRANS TYPE A1-8

CALTRANS TYPE A2-8

8" HIGH CURBS

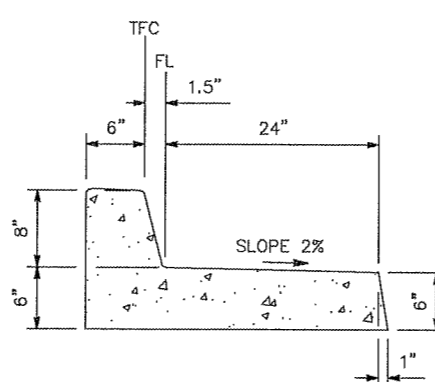

APWA TYPE A3-8
(SPILL GUTTER)

TEMPORARY PEDESTRIAN ACCESS NOTES:

- TEMPORARY ACCOMMODATION MUST BE MADE FOR PEDESTRIAN THOROUGHFARE DURING CONSTRUCTION.
- INTERSECTIONS MUST BE DEMOLISHED AND RECONSTRUCTED SEQUENTIALLY TO ALLOW ALTERNATE PEDESTRIAN ROUTE.
- ALTERNATE PEDESTRIAN ROUTE TO BE CLEARLY MARKED WITH SIGNAGE AND BARRICADES AND SHALL ADEQUATELY ALERT AND DIRECT PEDESTRIANS.

CURB & GUTTER NOTES:

- CALTRANS TYPE CURBS REFER TO CALTRANS REVISED STANDARD PLAN RSP A87A DATED "APPROVED" 11/18/2022.
- FIGURES HEREON ARE NOT DRAWN TO SCALE, UNLESS OTHERWISE NOTED (BUT ARE PROPORTIONAL).
- THE "1/4-INCH PER FOOT" RULE OF THUMB CAN RESULT IN A CROSS SLOPE OF 2.1% AND SHALL NOT BE USED. CROSS SLOPE SHALL BE LESS THAN 2%. GREATER THAN 2% WON'T PASS INSPECTION FOR COMPLIANCE.

GENERAL CR CONSTRUCTION NOTES:

1. CURB RAMPS (CR) SHALL HAVE A HEAVY BROOM FINISH PERPENDICULAR TO PATH OF TRAVEL.
2. NO NEW PULL BOX, UTILITY VAULT, UTILITY POLE, MANHOLE, OR SIMILAR APPURTENANCE SHALL BE LOCATED WITHIN THE CR LIMITS OF NEW CONSTRUCTION AREA UNLESS OTHERWISE SPECIFIED.
3. SEE CR PLACEMENT DETAIL FOR LOCATION AND CONSTRUCTION OF CRs WITHIN RETURN.
4. SW TRANSITION SHALL ACCOMMODATE MONOLITHIC RETAINING CURB, WHERE REQUIRED. NEW CURB, GUTTER, AND SIDEWALK SHALL CONFORM TO EXIST CONDITIONS WITHIN SAID TRANSITION.
5. WHEN IMPROVEMENTS OR OTHER CONSTRAINTS EXIST AT BOW, ADJUST RADIUS OF CURB LINE TO ACCOMMODATE MIN 50" PATH OF TRAVEL, EXCLUDING THE CURB. APPROVAL FROM COUNTY PUBLIC WORKS AND ENGINEER ARE REQUIRED PRIOR TO THE START OF CONSTRUCTION.
6. SLOPE OF ALL CR LANDINGS SHALL NOT EXCEED 1.5% IN ANY DIRECTION.
7. THE LEADING EDGE OF DWS SHALL BE SET 6"-8" (MAX) FROM FACE OF CURB/FL (EDGE AT BOC).
8. SW AND CR CLEAR WIDTH MEASUREMENTS ARE DETERMINED EXCLUSIVE OF THE CURB WIDTH.
9. IT IS DESIRABLE TO LOCATE ALL DRAIN INLETS OUT OF CR AREA; PREFERABLY UPHILL OF THE CR. USE OF DRAIN INLET WITHIN CR AREA REQUIRES PREVIOUS APPROVAL BY THE ENGINEER.
10. COUNTY PUBLIC WORKS OR ENGINEER SHALL COORDINATE LIMITS OF CONFORM PAVING WITH CONTRACTOR (OR IF SURVEY IS REQUIRED FOR CONSTRUCTION).
11. DWS SHALL BE CAST IN PLACE PREFABRICATED POLYMER INCLUDING ALUMINUM OXIDE ("ARMOR-TILE" OR EQUAL) COLOR TO BE FEDERAL COLOR No. 33538 OR APPROVED EQUAL. DOMES SHALL BE 'IN-LINE' PATTERNS, PARALLEL TO CURBING, WITH A HEIGHT OF 0.2", BASE DIAMETER OF 0.9" MIN TO 0.92" MAX, AND TOP DIAMETER OF 0.45" MIN TO 0.47" MAX, SPACED 2.35" O.C. FIELD SURFACE AND TOP OF DOMES TO HAVE A DOTTED TEXTURE FOR SLIP RESISTANCE. DENSITY OF DOTS IN FIELD AREA SHALL BE 30 PER SQUARE INCH MIN. MIN DEPTH OF DWS SHALL BE 3" AND THE WIDTH SHALL MATCH THE LANDING PAD WIDTH OR CR WIDTH. DWS SHALL EXTEND THE FULL WIDTH OF THE CR RUN, LESS 0.10' MAX ON EACH SIDE, EXCLUDING ANY FLARED CRs ON EITHER SIDE OF THE LANDING.

EXCEPTION: 'GLUE AND SCREW' (SURFACE MOUNT) MAY BE APPROVED BY ENGINEER WHEN SECTION OF SURFACE WHERE DWS WILL BE PLACED IS NOT BEING RECONSTRUCTED.



**COUNTY OF HUMBOLDT
DEPARTMENT OF PUBLIC WORKS**

BAR BELOW IS ONE INCH ON ORIGINAL DRAWING IF NOT ONE INCH ON THIS SHEET, ADJUST SCALES ACCORDINGLY	ENGINEERING DESIGN SECTION		COUNTY OF HUMBOLDT DEPARTMENT OF PUBLIC WORKS	SHEET 9 OF 12
	CONTRACT NO.: 325701 DWG. FILE NAME: HUMCO DESIGN PHASE 3 PLOT DATE: 03/20/23	DESIGNED BY: WMH DRAWN BY: WMH REVIEWED BY: AHS APPROVED BY: TRS	ADA CURB RAMP IMPROVEMENTS (PHASE 3)	

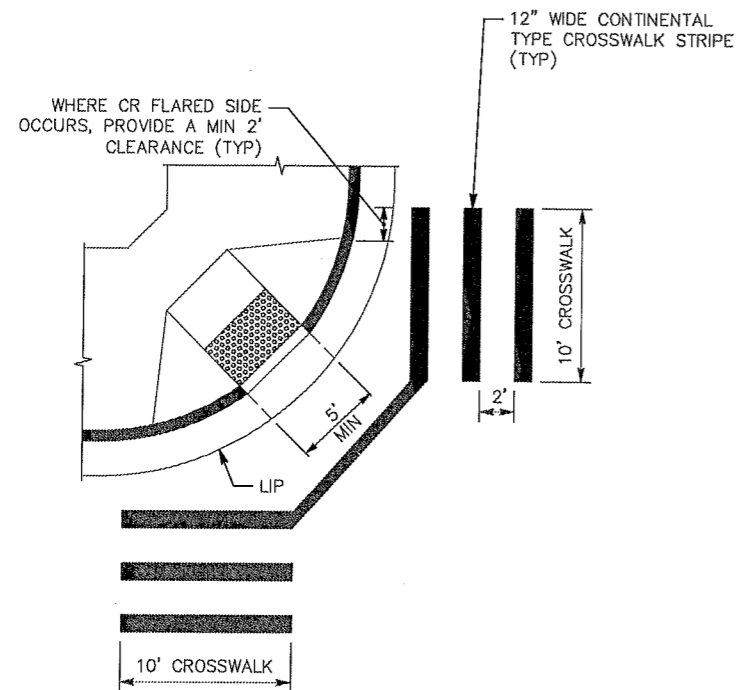

1
—
CROSSWALK LINE DETAIL
NTS

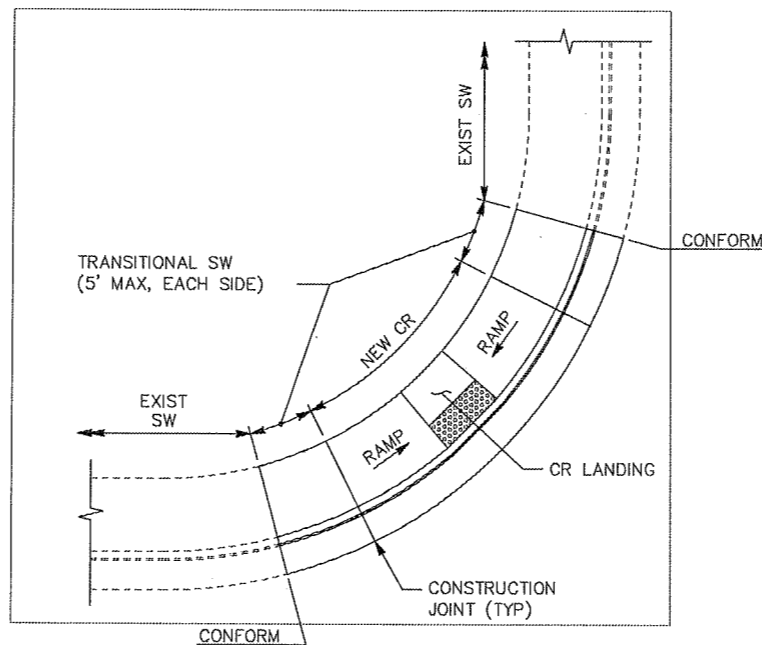

3
—
CR CONFORM TO EXIST SW DETAIL
NTS

NOTES:

1. WHEN EXISTING SW HAS A CROSS SLOPE THAT EXCEEDS 2% PROVIDE A 2' MIN TO 5' MAX LENGTH TRANSITION SW TO CONFORM TO THE EXIST SW CROSS SLOPE. PROVIDE A CONSTRUCTION JOINT TO ALLOW THE TRANSITION SW TO BE EASILY REMOVED WHEN SW IS REPLACED. (NOTE: SAWCUT LINE AND LIMITS NOT SHOWN FOR CLARITY)
2. EXCEPTIONS TO 5' MIN. TRANSITION SQUARE LENGTH TO BE COORDINATED AND/OR APPROVED BY COUNTY PUBLIC WORKS OR ENGINEER

	CURB RETURN RADIUS TABLE		
	LOCAL ROAD	COLLECTOR ROAD & ARTERIAL ROAD	INDUSTRIAL USE AREAS & TRUCK ROUTES
LOCAL ROAD	15'	20'	N/A
COLLECTOR ROAD & ARTERIAL ROAD	20'	25'	40'
INDUSTRIAL USE AREAS & TRUCK ROUTES	N/A	40'	40'

2
—
COUNTY CURB RETURN RADIUS TABLE

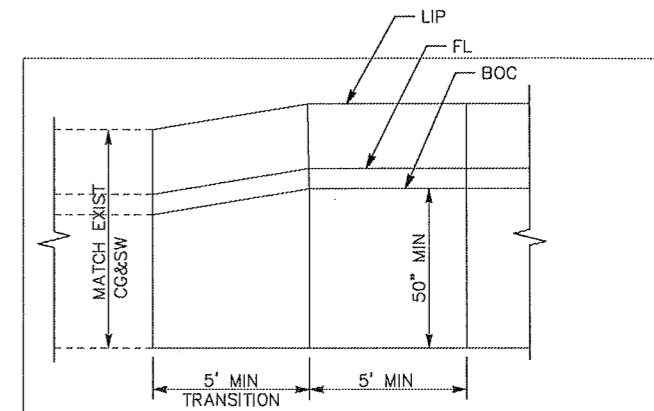

TRANSITION SW AT GUTTER

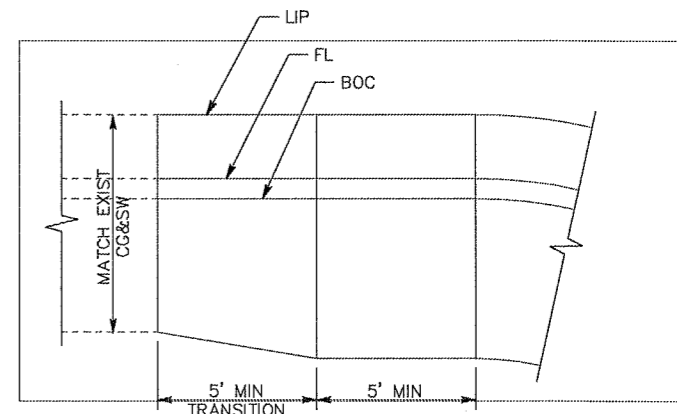

TRANSITION SW AT BOW

NOTE:

SW WIDTH TRANSITION TO BEGIN A MIN OF 5' AWAY FROM TOP OF CR FLARE LIMIT.

4
—
SW TRANSITION DETAIL



COUNTY OF HUMBOLDT
DEPARTMENT OF PUBLIC WORKS

BAR BELOW IS ONE INCH ON ORIGINAL DRAWING IF NOT ONE INCH ON THIS SHEET, ADJUST SCALES ACCORDINGLY	ENGINEERING DESIGN SECTION		COUNTY OF HUMBOLDT DEPARTMENT OF PUBLIC WORKS	SHEET 10 OF 12
	CONTRACT NO.: 325701	DESIGNED BY: WMH	ADA CURB RAMP IMPROVEMENTS (PHASE 3)	
DWG. FILE NAME: HUMCO DESIGN PHASE 3	DRAWN BY: WMH	REVIEWED BY: AHS	STANDARD DETAILS	
PLOT DATE: 03/20/23	APPROVED BY: TRS			

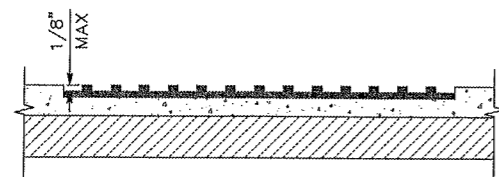
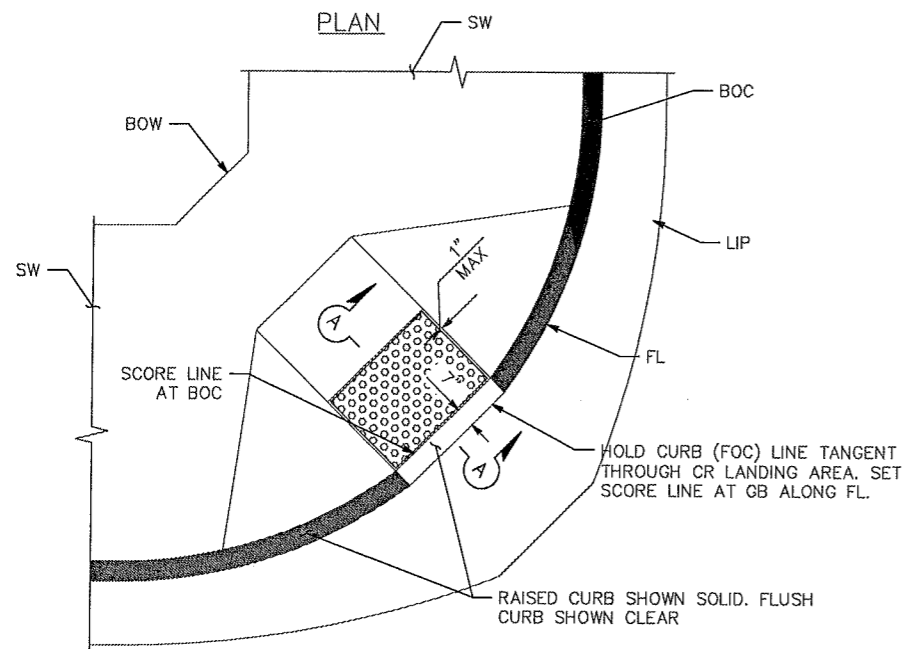

SECTION A-A

NOTES:

- DWS SHALL BE CAST IN PLACE.
- DWS SHALL BE FLUSH WITH RAMP AND HAVE A MAX VERTICAL TOLERANCE OF 1/8".

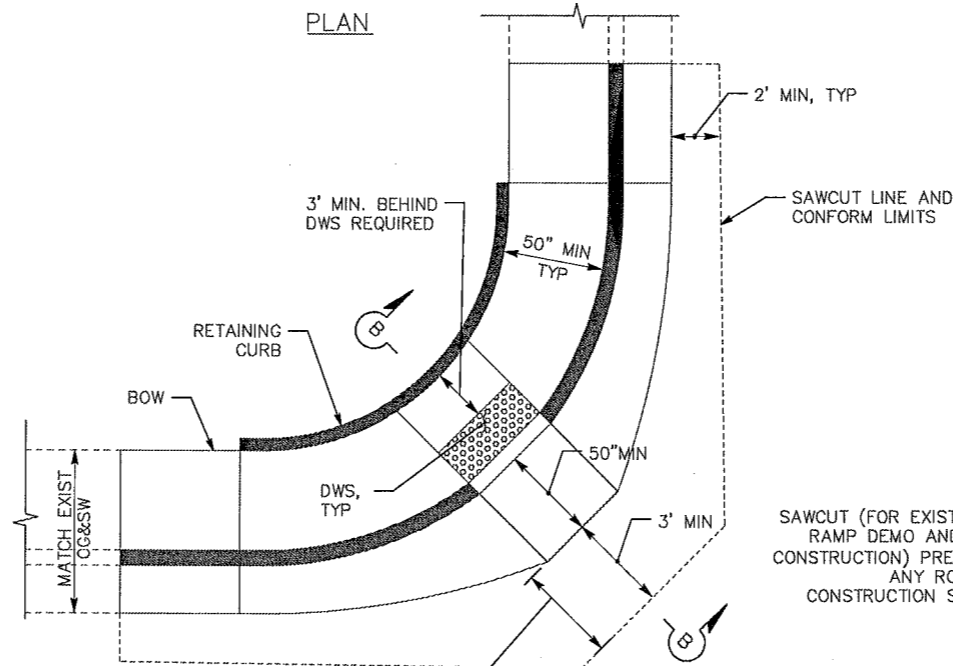

AREA OF HMA REMOVAL & REPLACEMENT (3' MIN TO 14' MAX) SHALL CONFORM TO INCORPORATED GUTTER LIP GRADING BASED ON THE PROVIDED CR DETAILS. SEE CR LANDING SECTION "B-B" BELOW.

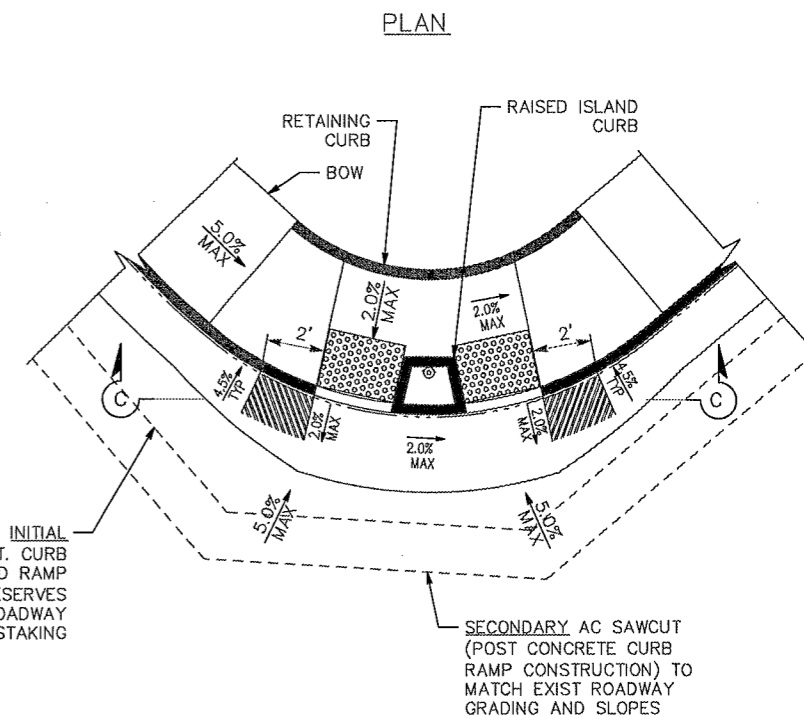

NOTES:

- INITIAL CLEAN SAWCUT TO BE MADE WITHIN ROADWAY CONSTRUCTION STAKING POINTS.
- SECONDARY SAWCUT FOR AC CONFORM TO BE PERFORMED AFTER CONCRETE CURB RAMP IS CONSTRUCTED



DETECTABLE WARNING SURFACE (DWS) DETAIL

NTS

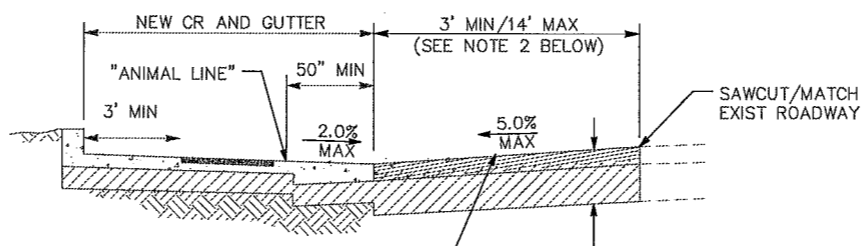

SLOPE SHALL NOT EXCEED 5.0% AT ROAD SURFACE IMMEDIATELY ADJACENT TO CURB RAMP LANDING

SECTION B-B

NOTES:

- COUNTY PUBLIC WORKS OR ENGINEER SHALL COORDINATE LIMITS OF CONFORM PAVING WITH CONTRACTOR (OR IF SURVEY IS REQUIRED FOR CONSTRUCTION).

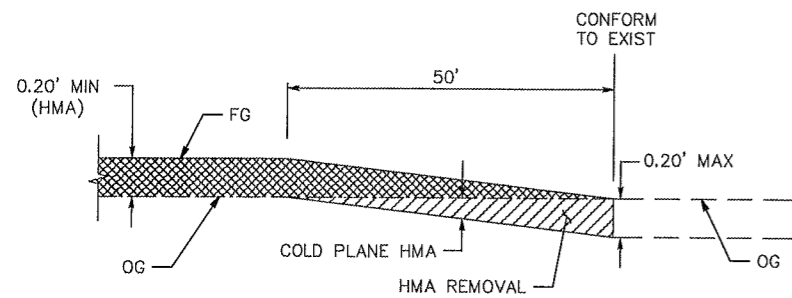

HMA PAVEMENT CONFORM GRIND
SECTION DETAIL

NTS



CURB RAMP PAVEMENT DETAIL

NTS

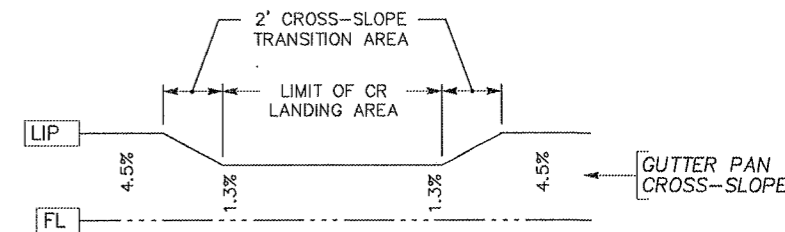

SECTION C-C

NOTES:

- GUTTER PAN CROSS-SLOPE WITHIN CR LANDING AREA LIMITS SHALL BE A MAX OF 1.3%; 1.3% MAX SLOPE ALONG THE LANDING FL. WHERE A CHANGE IN DIRECTION TAKES PLACE AT BOTTOM OF RAMP; 50" x 50" WIDE REINFORCED CONCRETE GUTTER PAN WILL BE CONSTRUCTED WITHIN PATH OF TRAVEL.
- MIN ALLOWED ADA SW CLEARANCE TO ANY EXIST ABOVE-GRADE APPURTENANCES SHALL BE 36" MIN. (SPECIFICALLY APPROVED CIRCUMSTANCES ONLY), 48" PREFERRED.



CURB RAMP GUTTER PAN CROSS-SLOPE TRANSITION
DETAIL

COUNTY OF HUMBOLDT
DEPARTMENT OF PUBLIC WORKS

BAR BELOW IS ONE INCH ON ORIGINAL DRAWING IF NOT ONE INCH ON THIS SHEET, ADJUST SCALES ACCORDINGLY	ENGINEERING DESIGN SECTION		COUNTY OF HUMBOLDT DEPARTMENT OF PUBLIC WORKS	SHEET 11 OF 12
	CONTRACT NO.: 325701 DWG. FILE NAME: HUMGO DESIGN PHASE 3 PLOT DATE: 03/20/23	DESIGNED BY: WMH DRAWN BY: WMH REVIEWED BY: AHS APPROVED BY: TRS	ADA CURB RAMP IMPROVEMENTS (PHASE 3) STANDARD DETAILS	

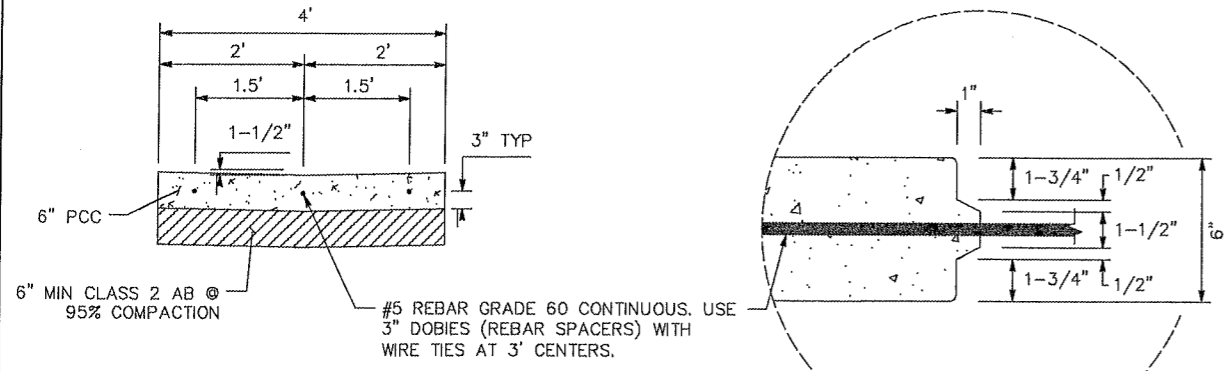

SECTION A-A

REINFORCING STEEL TO BE EXTENDED 12" MIN & SPLICED ACCORDING TO STATE SPECIFICATIONS

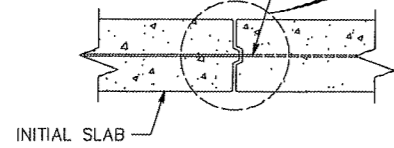

2 CONTACT JOINT DETAIL
NTS

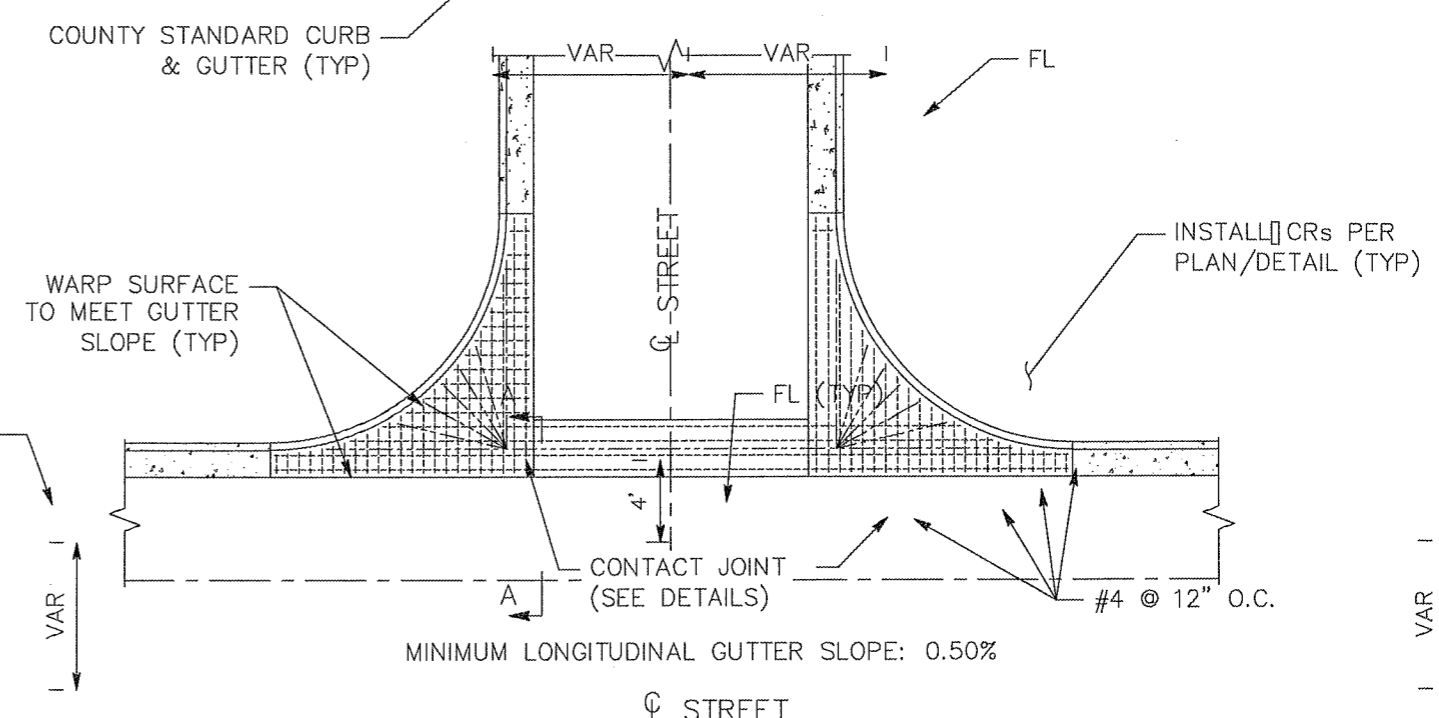

PLAN

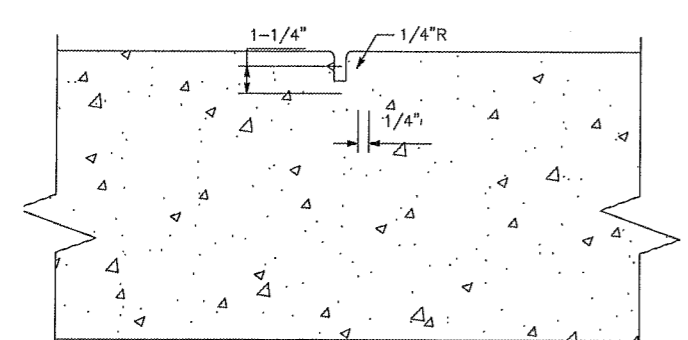

3 WEAKENED PLANE JOINT DETAIL
NTS

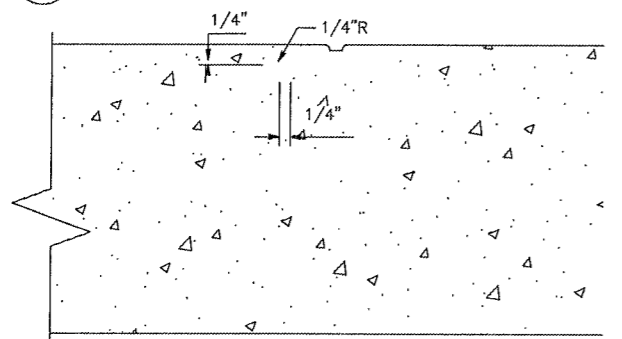

4 SCORE MARK DETAIL
NTS

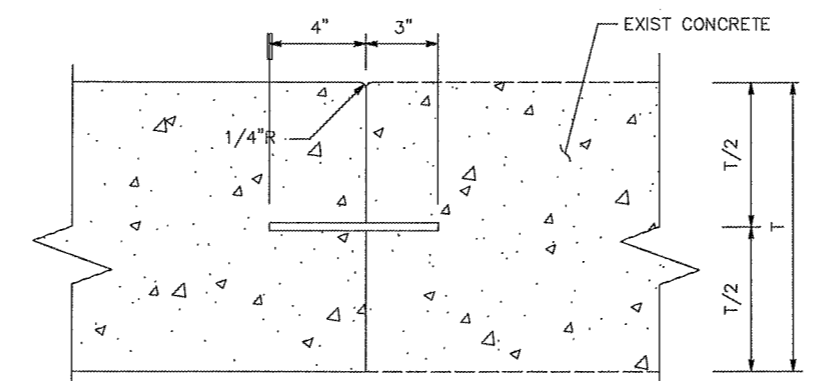

6 SIDEWALK CONTACT JOINT DETAIL
NTS

1

CROSS GUTTER DETAIL
NTS

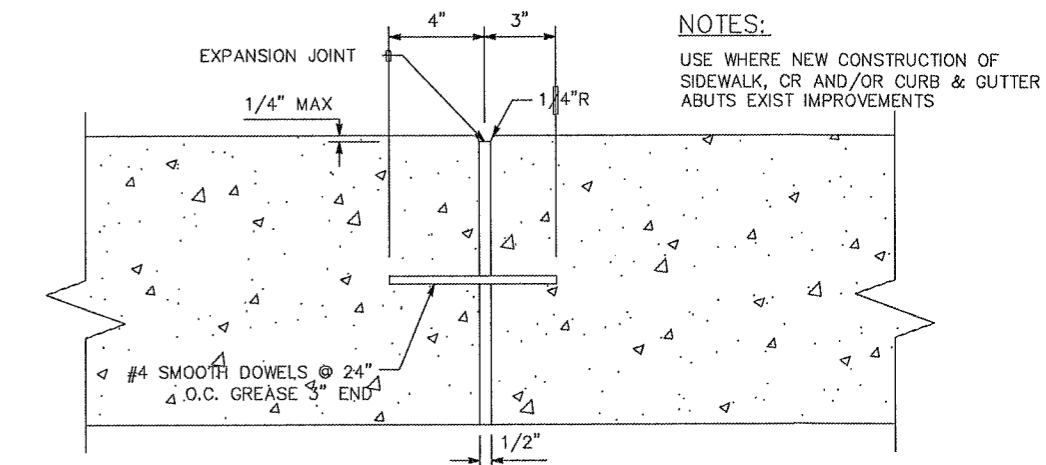

NOTES:
USE AT 60' ON CENTER IN SIDEWALK CURB & GUTTER, MEDIAN CURBS, & MEDIAN FLATWORK. ALSO USE AT MAJOR CORNER RETURNS, SIDES OF CRs, DRIVEWAYS & LOCATIONS SHOWN ON PLANS & AS SPECIFIED IN SPECIFICATIONS.

5

EXPANSION JOINT DETAIL
NTS

NOTES:
USE WHERE NEW CONSTRUCTION OF SIDEWALK, CR AND/OR CURB & GUTTER ABUTS EXIST IMPROVEMENTS



COUNTY OF HUMBOLDT
DEPARTMENT OF PUBLIC WORKS

BAR BELOW IS ONE INCH ON ORIGINAL DRAWING IF NOT ONE INCH ON THIS SHEET, ADJUST SCALES ACCORDINGLY	ENGINEERING DESIGN SECTION		COUNTY OF HUMBOLDT DEPARTMENT OF PUBLIC WORKS		SHEET 12 OF 12
	CONTRACT NO.: 325701 DWG. FILE NAME: HUMCO DESIGN PHASE 3 PLOT DATE: 03/20/23	DESIGNED BY: WMH DRAWN BY: WMH REVIEWED BY: AHS APPROVED BY: TRS	ADA CURB RAMP IMPROVEMENTS (PHASE 3)		
STANDARD DETAILS					

NOTES:

- UTILITY POLE GUY WIRE RELOCATION BY OTHERS. THAT WORK IS NOT SHOWN AND NOT IN THIS CONTRACT.
- THE PREFERRED CLEAR APPROACH AREA (TO MEET ADA) WILL COVER A 4'-2" (50") WIDE BY 7' TALL SWATH.
- CONTRACTOR TO SUPPLY & INSTALL PERFORATED BREAK AWAY ROAD SIGN POST SLEEVE AND POST. USE A 3" SQ TUBE X 3' LONG, 3/16" THICK ANCHOR FOR 2 1/2" POSTS.
- COUNTY TO SUPPLY UPDATED ROAD SIGNS.
- USE A 3/8" CORNER BOLT OR TWO DRIVE RIVETS TO FASTEN ASSEMBLED SIGN AND POST INTO ANCHOR. INSTALL CORNER BOLT OR DRIVE RIVETS INTO THE SIDES FACING TRAFFIC.
- 2 1/2" POSTS ARE TO BE 10 GA, PERFORATIONS OF 7/16" IN DIAMETER AT 1" OC ON ALL SIDES.
- FOR DETAILS NOT SHOWN, REFER TO THE CALTRANS STANDARD PLANS.
- ALL ANCHOR SLEEVES SHALL BE EMBEDDED IN CONCRETE
- BOTTOM OF SIGN SHALL BE 80" ABOVE FINISH GRADE WHEN LOCATED IN A SIDEWALK OR PEDESTRIAN PATHWAY.
- INSTALL ANCHOR AT A 4 DEGREE DEFLECTION AWAY FROM TRAFFIC & KEEP 2 PERFORATIONS ABOVE GRADE.

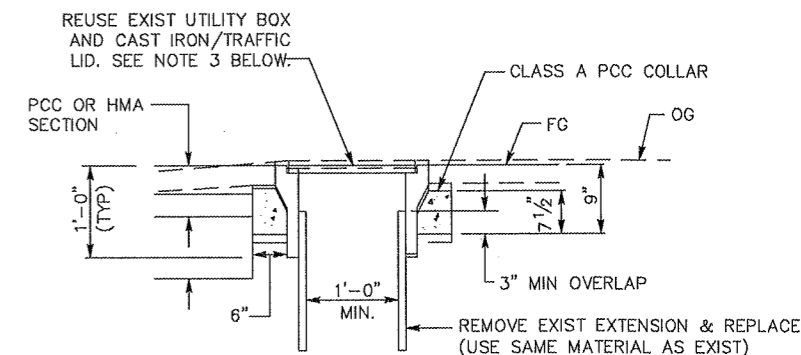
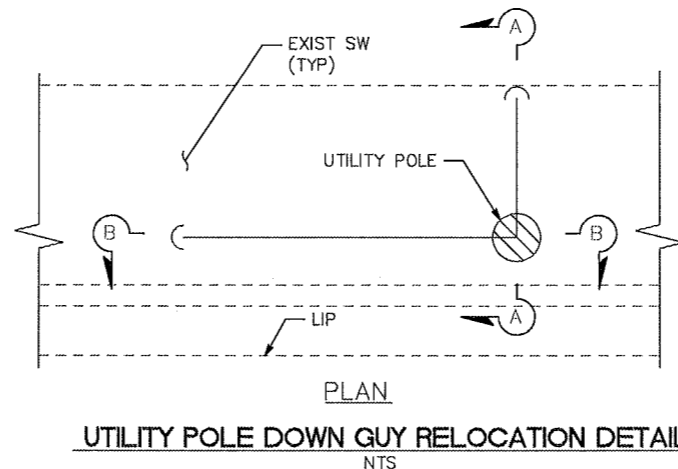

NOTES:

- FOR ALL VALVE BOXES, PULL BOXES, TRAFFIC SIGNAL BOXES, AND SEWER CLEANOUTS.
- WATER VALVE BOX SHOWN ABOVE FOR EXAMPLE.
- RESIDENT ENGINEER SHALL DETERMINE CONDITION OF LID FOR REUSE.



ADJUST UTILITY BOX TO GRADE DETAIL

NTS

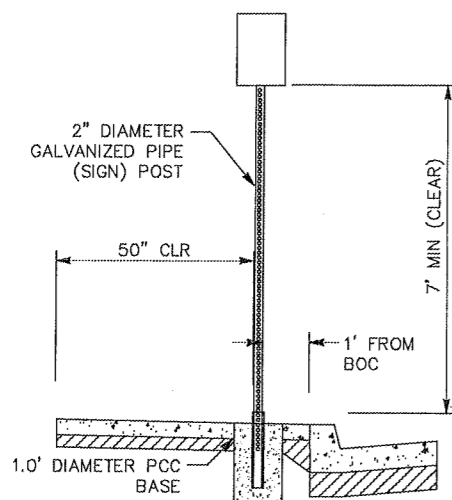

SECTION A-A

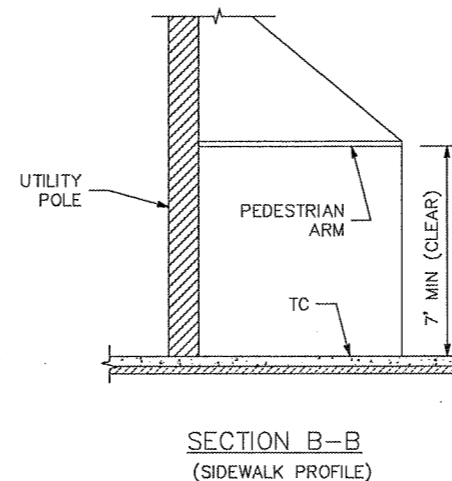
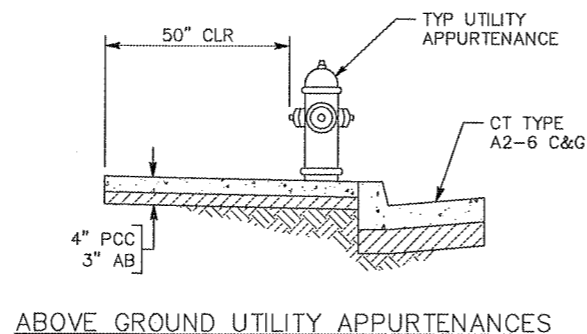

SECTION B-B
(SIDEWALK PROFILE)

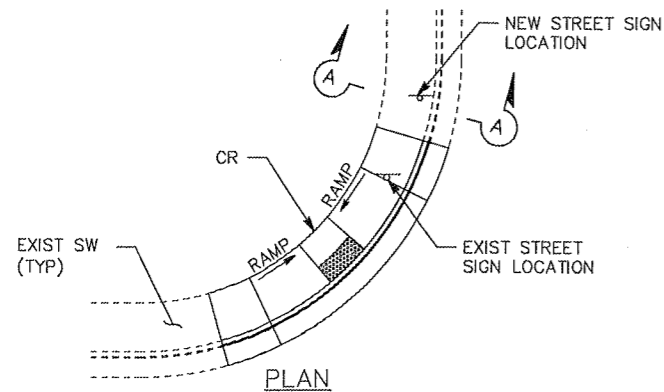

1 STREET SIGN PLACEMENT (SW OBSTRUCTION)
NTS

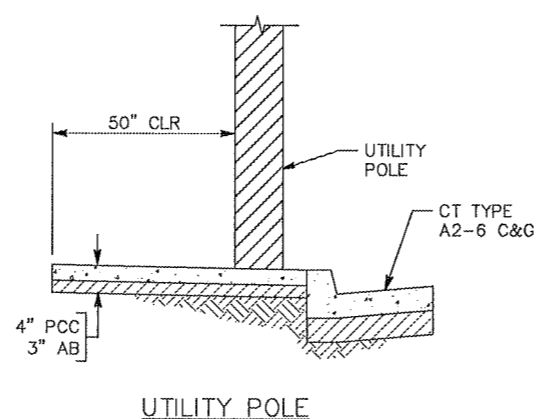

UTILITY POLE

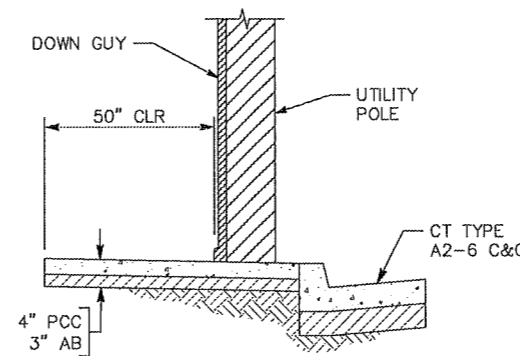

UTILITY POLE (w/ DOWN GUY)

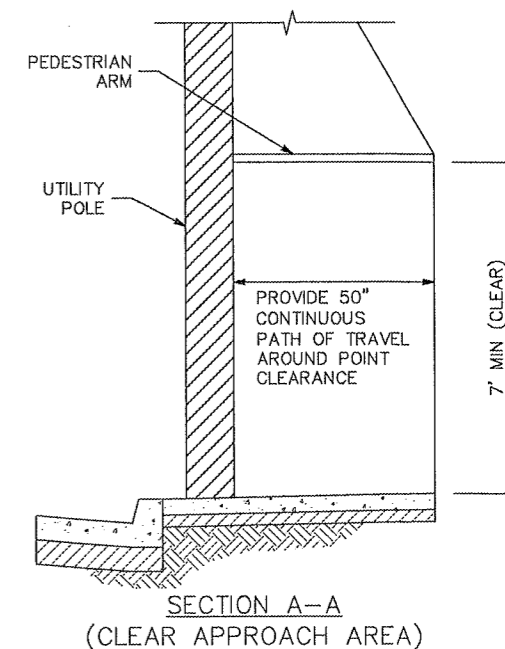

SECTION A-A
(CLEAR APPROACH AREA)

3 CLEAR APPROACH AREA (SW OBSTRUCTIONS)
NTS