

**Five-Year  
Capital Improvement Program  
2023-2024**

***DRAFT***



**Determined to be consistent with the General Plan by the Planning Commission on May 9, 2023**

**Adopted by the City Council on **June 5, 2023****

**City of Fortuna**  
**Five-Year Capital Improvement Program**  
**FY 2023-2024**

**MAYOR**  
Tami Trent

**CITY COUNCIL**  
Mike Johnson, Mayor Pro Tem  
Mike Losey  
Kyle Conley  
Kris Mobley

**CITY MANAGER**  
Merritt Perry

**DIRECTOR OF PUBLIC WORKS/CITY ENGINEER**  
Brendan Byrd

# Table of Contents

<b>INTRODUCTION .....</b>	<b>1</b>
<b>SUMMARY .....</b>	<b>4</b>
<b>WATER TREATMENT AND DISTRIBUTION .....</b>	<b>7</b>
<b>WASTEWATER TREATMENT AND COLLECTIONS .....</b>	<b>21</b>
<b>DRAINAGE SYSTEMS .....</b>	<b>30</b>
<b>STREETS .....</b>	<b>37</b>
<b>PARKS AND RECREATION.....</b>	<b>49</b>
<b>COMPLETED AND IN PROGRESS PROJECTS .....</b>	<b>62</b>

# Introduction

Fortuna, known as “The Friendly City,” was incorporated in 1906 and is a small, rural community of just over 12,000 residents and covering an area of 5.1 square miles. The City of Fortuna is governed by a Council/Manager form of government. The City Council consists of five members, elected from the City at large, who serve four-year terms. The Mayor and the Mayor Pro Tem are elected biannually by the City Council from amongst its members. The City Manager works under the direction of the City Council and is responsible for supporting the policies enacted by the City Council, as well as managing the day-to-day operations of the City.

The City of Fortuna’s mission is “To be worthy of the public trust by providing timely, efficient, well-planned, and dependable services to the community.” Part of the City’s commitment to this mission is through a well-planned Five-Year Capital Improvement Program that works to maintain and replace aging facilities as well as construct new infrastructure, as it is needed.

**What is a Capital Improvement Program?** A Five-Year Capital Improvement Program (CIP) is a multi-year planning instrument used to identify needed capital improvement projects and to coordinate the financing and timing of improvements. The primary purpose of the CIP is to assist in the orderly implementation of the broad and comprehensive goals of the adopted General Plan and for the maintenance and replacement of the City’s infrastructure by establishing an orderly basis to guide local officials in making sound budget decisions and by focusing attention on community goals, needs, and capabilities to maximize the benefit of public expenditures.

Projects may include land and buildings, park and recreation facilities, street and storm drain facilities, wastewater collection and treatment facilities, and water treatment and distribution facilities.

## **An effective Capital Improvement Program:**

1. Identifies specific public improvement projects by location, size, function, and cost (although some types of projects, such as street resurfacing and maintenance of water and sewer facilities may be shown on an annual allocation basis).
2. Establishes the timing for funding of major cost elements related to each project, such as right-of-way acquisitions, design, construction, etc.; for large projects, these may be spread over several years, while for smaller projects, only a single budget year is involved.
3. Proposes specific revenue sources for each project.
4. Facilitates priority setting where funds are insufficient to cover all desired projects.
5. Enhances coordination of separate but interrelated projects, whether internal or involving other agencies.
6. Gives other affected agencies, such as utilities, an opportunity to develop long-range programming.
7. Tends to discourage inefficient and frequent changes in allocation of capital resources.
8. Permits an educated approach to staffing for engineering, operation, and maintenance.



For most cities, a five-year CIP period appears to be workable and realistic. Under this guideline, it is common for the first year of the CIP to be combined into the annual budget process. In all cases, the CIP would be flexible enough to make the inevitable adjustments for unanticipated cost changes, urgent projects, or other factors. In addition, the City will be able to more clearly identify and discuss the consequences of a delay in timely project commencement due to such factors.

**How are projects funded?** Funding for projects is usually derived from special source funds including gas tax, water reserves, sewer reserves, remaining balances of the General Fund, or state, federal, and other grants.

Gas tax, water, and sewer fund revenues are budgeted only for capital projects in the categories appropriate to their sources.

The General Fund's ability to make significant contributions to the CIP has been declining over the last several years by a combination of factors. The City's General Fund has had its revenues reduced by the State budget crisis. The General Fund currently does not have the ability to finance capital improvement projects in the same way that is has done in the past.

Federal, state, and other grant funds may only be used for the purpose for which the funds were received.

Although this CIP falls short of funding the optimum level of infrastructure improvements, it does represent an effort to use all available funding sources for the most vital projects.

**Project priorities should be established by:**

1. Projects with a clear issue of public health and safety.
2. Projects which trigger irreversible or serious long-range consequences.
3. Projects that eliminate liabilities experienced in the past.
4. Projects mandated by county, state and/or federal laws, the public and other agencies.
5. Projects directly related to established goals or objectives.
6. Projects directly affecting the quality of life for residents of the City of Fortuna.

Every effort is made to ensure that all projects are described accurately and have sound cost estimates. Some projects are conceptual in nature and these cost estimates are difficult to generate and should be considered flexible.

Estimates are initially made for every project in 2023 dollars. As priorities for construction are assigned for each project, the dollar amount is updated to more accurately reflect costs within the proposed year of construction. **The estimates are general with the intent that they should be revised as they are brought into the annual budget process.**

The projects identified in this 2023-2028 CIP are considered essential in order to implement goals, protect public property from deterioration and extending its useful life, and preserve the City's prior infrastructure investments.

In summary, the 2023-2028 Five-Year Capital Improvement Program is a planning and budgeting tool that lists and classifies all proposed public improvement projects maximizing the investment to the public.

Respectfully Submitted,

---

Brendan Byrd  
Director of Public Works/City Engineer

---

Merritt Perry  
City Manager

# Summary

## Projected Project Costs by Year and Department

	2023/2024	2024/2025	2025/2026	2026/2027	2027/2028
<b>Water</b>	\$1,710,000	\$1,900,000	\$1,350,000	\$880,000	\$750,000
<b>Wastewater</b>	\$3,015,000	\$800,000	\$10,550,000	\$10,100,000	\$800,000
<b>Drainage</b>	\$1,271,900	\$305,000	\$660,000	\$800,000	\$200,000
<b>Streets</b>	\$2,429,500	\$600,000	\$600,000	\$960,000	\$600,000
<b>Parks/Recreation</b>	\$1,015,000	\$90,000	\$3,000,000	\$0	\$0
<b>Land/Buildings</b>	\$2,575,000	\$150,000	\$1,000,000	\$0	\$0
<b>Totals</b>	\$12,016,400	\$3,845,000	\$17,160,000	\$12,740,000	\$2,350,000

**Total of all projects in this CIP: \$48,111,400**

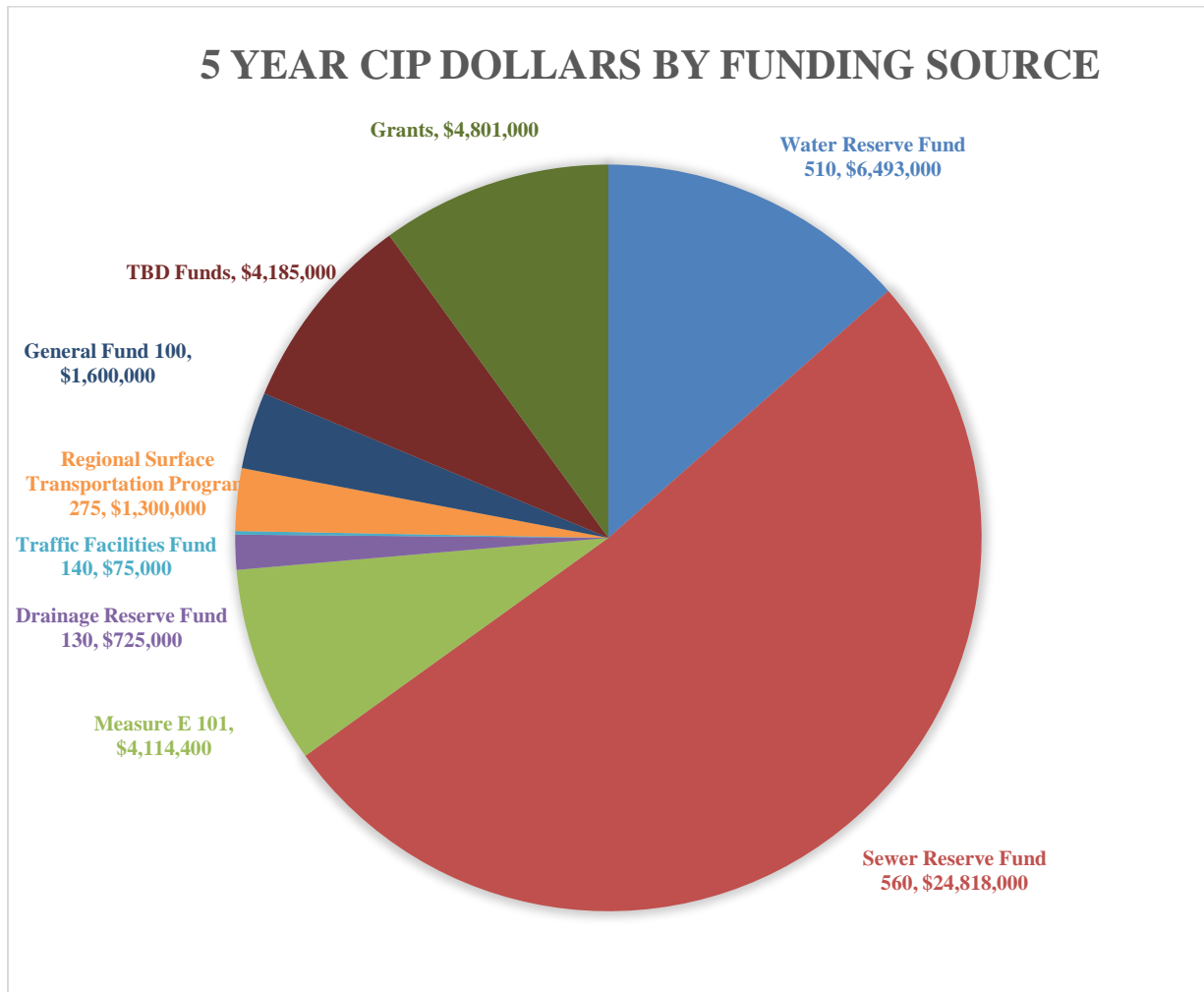

## 2023/2024 FY PROJECTS BY FUNDING SOURCE

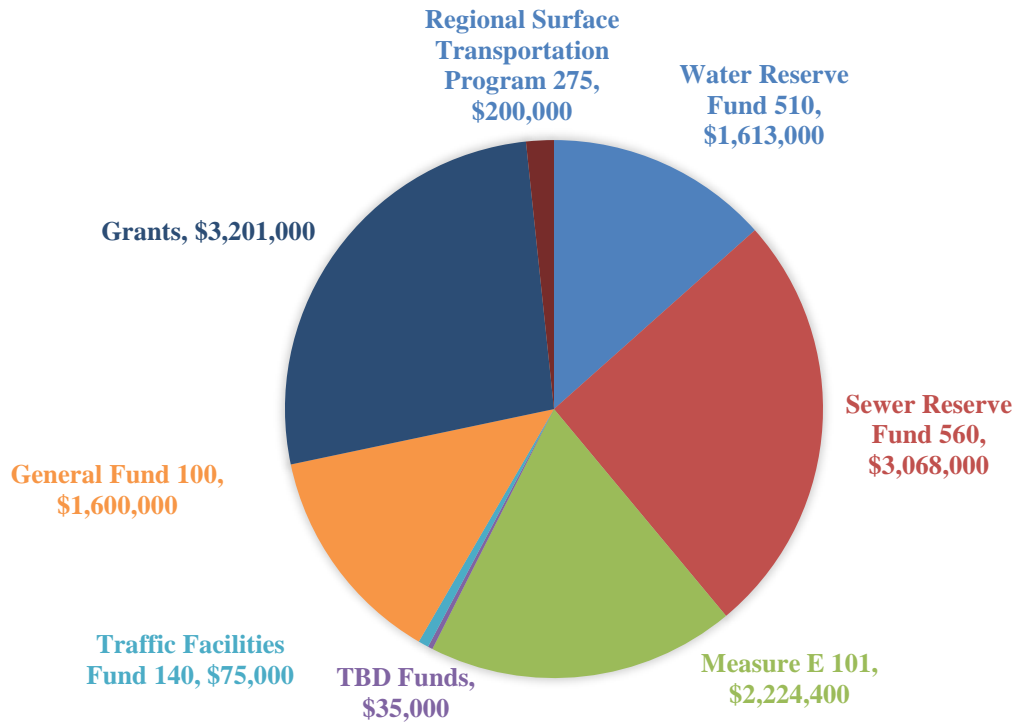

## TOTAL CIP FUNDS BY USAGE

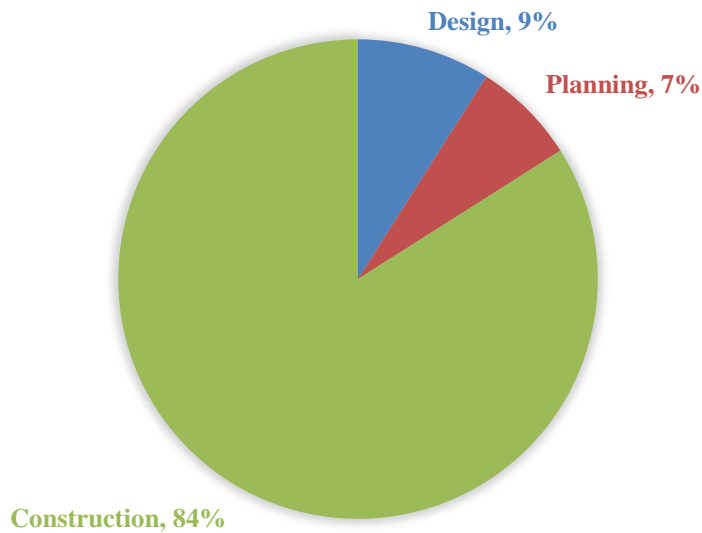



# Water Treatment and Distribution





## Description

Road, fence, and drainage repairs as needed.

## Justification

This project will repair damage done to the access road over previous years of projects and maintenance as well as repair damaged fences due to falling redwood limbs and small trees. Drainage spouts will be inspected and repaired as needed.

## Studies and Reports

Identified and recommended by the Water Treatment Crew.

## Funding Sources

Water Reserves Fund 510

## Prior Appropriations

Water Reserves Fund 510;  
Repairs \$105,676

## Comments

The main project elements include fencing, tree removal, roadway repairs, rock slope protection, and drainage improvements. Tree removal was completed in late 2022/early 2023, and remaining items include fencing and drainage improvements.



(Chief Plant Operator)

## Project Cost Estimate

	<b>2023 Dollars</b>	
1. Construction	\$200,000	23/24
<b>Total</b>	<b>\$200,000</b>	

## Description

Replacement of the underground source main pipes at the Corrosion Control Facility. Construction of a new shallow well in place of previously drilled Well 5b. Addition of various electronic and metering equipment for the new well.

## Justification

Current piping configuration results in pump inefficiencies from the water wells. The updated pipe configuration will create the most efficient operation for each well pump. Well 5 was previously underperforming, and the new Well 5b was found to have levels of manganese that require robust and expensive treatment in order to bring the well online.



## Studies and Reports

Identified and recommended by City Consultant.

## Funding Sources

Water Reserves Fund 510

## Prior Appropriations

Water Reserve Fund 510;  
Modeling and Design \$22,000  
Construction \$250,000



## Comments

(Chief Plant Operator)

## Project Cost Estimate

	2023 Dollars	
1. Construction	\$300,000	23/24
<b>Total</b>	<b>\$300,000</b>	



# Water Tank Recoating Project

CIP# 0925

## Description

External recoating of the Hillside and Campton Heights potable water storage tanks.

## Justification

This project is part of the regular maintenance of vital infrastructure. It will prevent corrosion of the metal water storage facilities as well as potential water quality issues.

## Studies and Reports

Identified and recommended by the Water Treatment Crew.

## Funding Sources

Water Reserves Fund 510

## Prior Appropriations

Water Reserve Fund 510;  
Tank Inspections \$3,375

## Comments

Construction anticipated to being in late fiscal year 2022/23, and continue into following year.



(Chief Plant Operator)

## Project Cost Estimate

2023 Dollars

1. Construction	\$600,000	23/24
-----------------	-----------	-------

<b>Total</b>	<b>\$600,000</b>	
--------------	------------------	--

# **Kenmar and Drake Hill Pump House Stationary GenSets CIP# 9102**

## **Description**

Install new stationary generators at two water pump houses (Kenmar and Drake Hill).

## **Justification**

During power outage events in Fortuna, staff has to take portable generators (some of which are out of compliance) to multiple locations to keep citizens with water. Staff received a grant from FEMA to purchase and install these two generators, which will allow for more reliable power to our vital locations, especially with the recently elongated events by PG&E power outages (PSPS).



## **Studies and Reports**

Humboldt County Operational Area Hazard Mitigation Update Plan Update (HCOAHMP, 2014)

## **Funding Sources**

FEMA Hazard Mitigation Grant Fund 351 75%  
Water Reserves Fund 510 25%

## **Prior Appropriations**

FEMA Hazard Mitigation Grant Fund 351  
Design: \$34,200  
Water Reserves Fund 510 25%  
Design: \$11,400



## **Comments**

(Public Works Director)

### **Project Cost Estimate**

	<b>2023 Dollars</b>	
1. Construction	\$200,000	23/24
<b>Total</b>	<b>\$200,000</b>	

# Water System Master Plan

CIP# 9109

## Description

Develop an updated master plan for the water system of the entire City. Perform a rate study to inform required adjustments to City water rates.

## Justification

This master plan will provide information that staff can use to identify improvements needed to develop future projects that protect the existing infrastructure and provide redundancy and a reliable water supply to the City.

## Studies and Reports

Previous master plan by Oscar Larson & Associates April 2007

## Funding Sources

Water Reserves Fund 510

## Prior Appropriations

N/A

## Comments

(Director of Public Works)

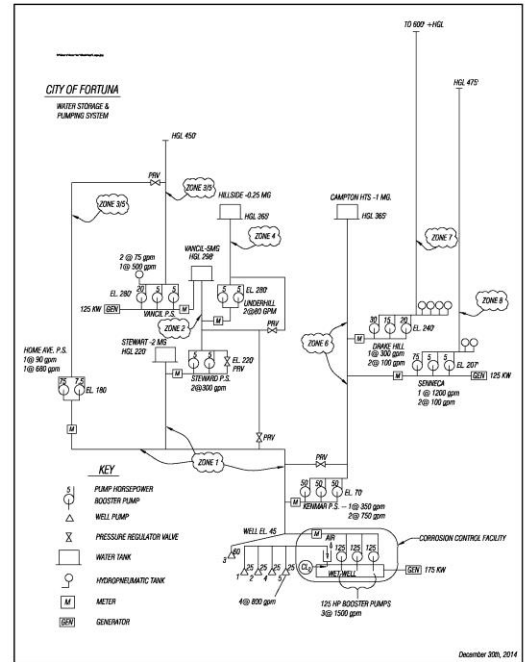

c:\load project files\water\water pressure grids\water storage & pumping system.dwg

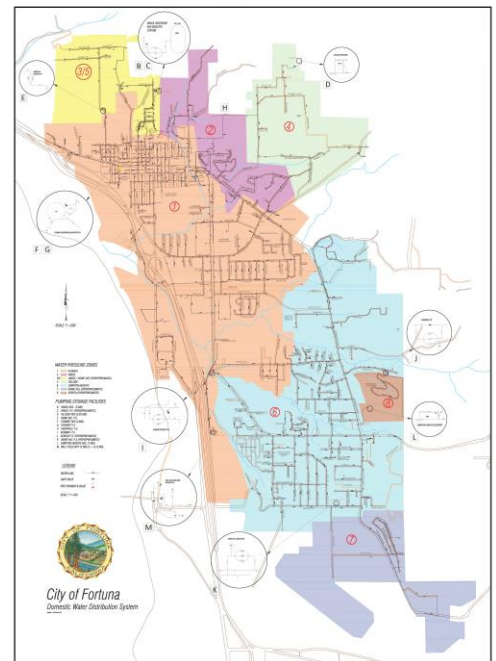

## Project Cost Estimate

2023 Dollars

1. Planning

\$150,000

23/24

**Total**

**\$150,000**



## Description

Replacement of the old 2” cast iron line with 6” C-900 (plastic) along the following alleys that connect I to L Street: the alley between 9<sup>th</sup> and 10<sup>th</sup> Street, the alley between 10<sup>th</sup> and 11<sup>th</sup> Street, and the alley between 11<sup>th</sup> and 12<sup>th</sup> Street. Also includes the alley connecting N to P Street between 13<sup>th</sup> and 14<sup>th</sup> Street, , replacement of the old 6” AC (concrete) with 6” C-900 (plastic) along Orchard Lane, replacement of the 4” cast iron pipe with 6” C-900 (plastic) on 14<sup>th</sup> Street from K Street to P Street, and replacement of the water main on Newburg Road between Fortuna Boulevard and Spring Street.



## Justification

The upgraded line will provide better flow rates to homes and businesses in the area. Additionally, it will eliminate potential corrosion and water quality issues that can come from the existing cast iron lines and increase line sizes for improved fire flows.



## Studies and Reports

Identified and recommended by the Utilities Crew.

## Funding Sources

Water Reserve Fund 510

## Prior Appropriations

N/A

## Comments

This project may be completed by City Forces with the rental or purchase of a mini excavator, or through contract and bid document (TBD). This project includes installation of a new hydrant on Orchard Lane. Additionally, this project may be combined with sewer CIP #9067 for construction.

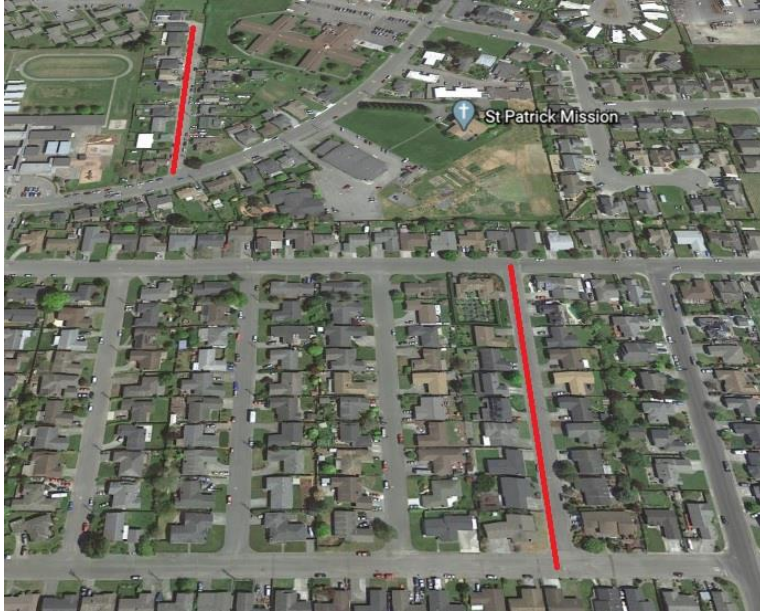

(Utilities Superintendent)

**Project Cost Estimate**

**2023 Dollars**

1. Design	\$160,000	23/24
2. Construction	\$1,800,000	24/25
<b>Total</b>	<b>\$1,960,000</b>	



# Drake Hill Road Water Main Replacement Project

CIP# 9115

## Description

Replace asbestos cement pipe waterline with 8" C900 (plastic)

## Justification

Currently some sections of Drake Hill Road are AC pipe while others are C900. The AC pipe is old and frequently causes leaks. This project would update all the sections to the newer C900 (plastic) pipe, which would decrease the likelihood of future leaks in this area.



## Studies and Reports

This project was identified by the Utilities Superintendent.

## Funding Sources

Water Reserves Fund 510

## Prior Appropriations

N/A

## Comments



(Utility Superintendent)

## Project Cost Estimate

	2023 Dollars	
1. Design	\$100,000	24/25
2. Construction	\$850,000	25/26
<b>Total</b>	<b>\$950,000</b>	

## Description

Replacement of failed concrete pipe in the section of an access road formerly known as Barney Street. Install a twenty-four inch high density Polyethylene pipe. The pipe is located below the Stewart Tank Reservoir near 1038 Eleventh Street.

## Justification

The concrete culvert has collapsed causing excess water to migrate. The overflow from Stewart Tank and surrounding storm water runoff uses this culvert. The City’s main water line runs parallel to the culvert.

## Studies and Reports

Identified and recommended by General Services Staff.

## Funding Sources

Water Reserves Fund 510

## Prior Appropriations

N/A

## Comments

The new culvert will start above the current existing Inlet and will extend approximately two hundred feet. The new culvert will tie into a newer drainage inlet and storm drain located on Eleventh Street.



(General Services Superintendent)

### Project Cost Estimate 2023 Dollars

1. Design	\$20,000	23/24
2. Construction	\$80,000	23/24
<b>Total</b>	<b>\$100,000</b>	

## Description

Relocation of the Electrical Panels at the Corrosion Control Facility to an elevation above the estimated 100-year flood event.

## Justification

This project will protect vital City infrastructure from damage that would occur during a 100-year flood event.

## Studies and Reports

Identified and recommended by the 2007 OLA Water System report.

## Funding Sources

Future FEMA HMGP Funding

## Prior Appropriations

N/A

## Comments



(Chief Plant Operator)

## Project Cost Estimate

2023 Dollars

1. Construction	\$200,000	25/26
<b>Total</b>	<b>\$200,000</b>	



# Meadow Lane Water Main Replacement Project

CIP# TBD

## Description

Replace with existing asbestos cement pipe with 6” C900 (plastic).

## Justification

Existing water main currently runs through the front yards of homes on the west side of Meadow Lane. This project would move water line into the street to provide easier access for repairs. This is also one of the last streets in this area with an AC water main and will be upgraded to C900 (plastic) which should lead to a decrease in the amount of leaks on this line.

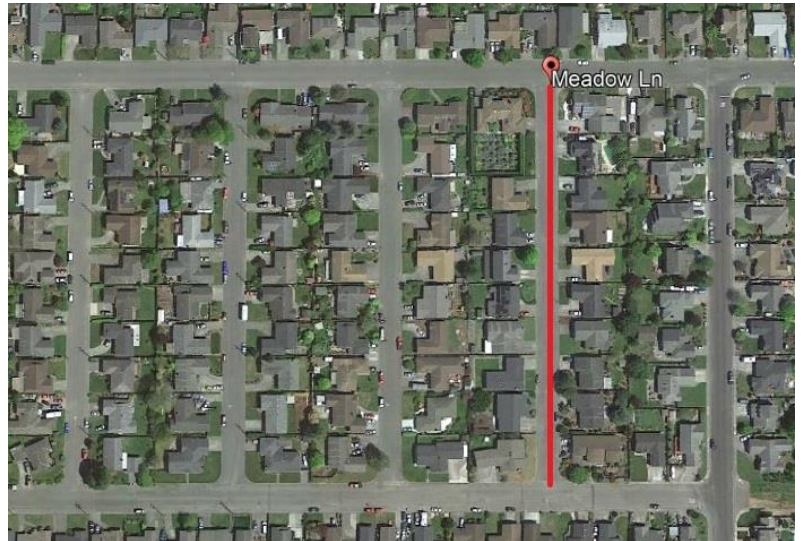

## Studies and Reports

Identified by the Utilities Crew.

## Funding Sources

Water Reserves Fund 510

## Prior Appropriations

N/A

## Comments



(Utilities Superintendent)

## Project Cost Estimate

2023 Dollars

1. Construction

\$220,000

25/26

**Total**

**\$220,000**

# 12<sup>th</sup> Street Water Main Project

CIP# 9065

## Description

Replacement of the existing 6” and 8” AC (concrete) mains with 12” C-900 (plastic) mains from L Street to Newburg Road.

## Justification

The existing mains are undersized concrete and will be replaced with the larger and more durable plastic to provide better flow rates to homes and businesses in the area.

## Studies and Reports

Identified and recommended by 2007 OLA Water System Report.



## Funding Sources

Water Reserves Fund 510

## Prior Appropriations

N/A

## Comments

May revisit project after completion of water study.

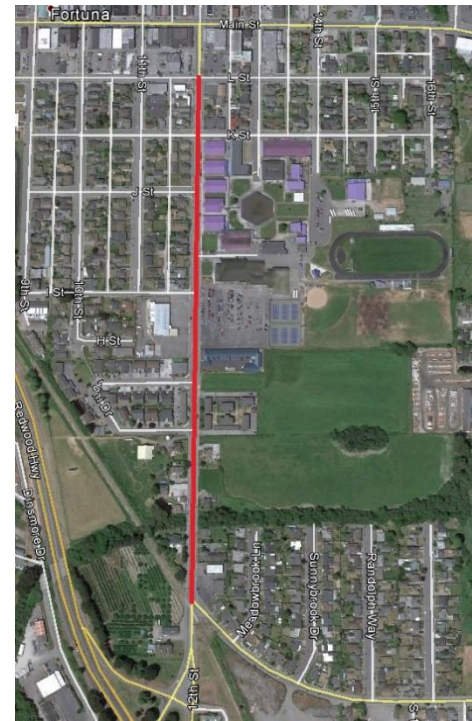

(Utility Superintendent)

## Project Cost Estimate

2023 Dollars

1. Design	\$80,000	25/26
2. Construction	\$800,000	26/27

**Total** **\$880,000**



# Carson Woods & Newell Drive Waterline Replacement CIP# TBD

## Description

Replace the existing 1” galvanized and plastic water line extending north along Carson Woods Road, beginning at Sunny Slopes Road. Add fire hydrants every 600-feet per requirements of the Fortuna Fire Department. Provide engineered bridge crossing for the water line. Replace service connections to existing meters.

## Justification

The existing water line is too small to deliver adequate service pressure and volumes to existing residences along Carson Woods Road. During recent earthquakes from the past several years, the pipe has regularly failed due to pipe age.

## Studies and Reports

N/A

## Funding Sources

Water Reserve Fund 510 or unidentified grant funds

## Prior Appropriations

N/A

## Comments

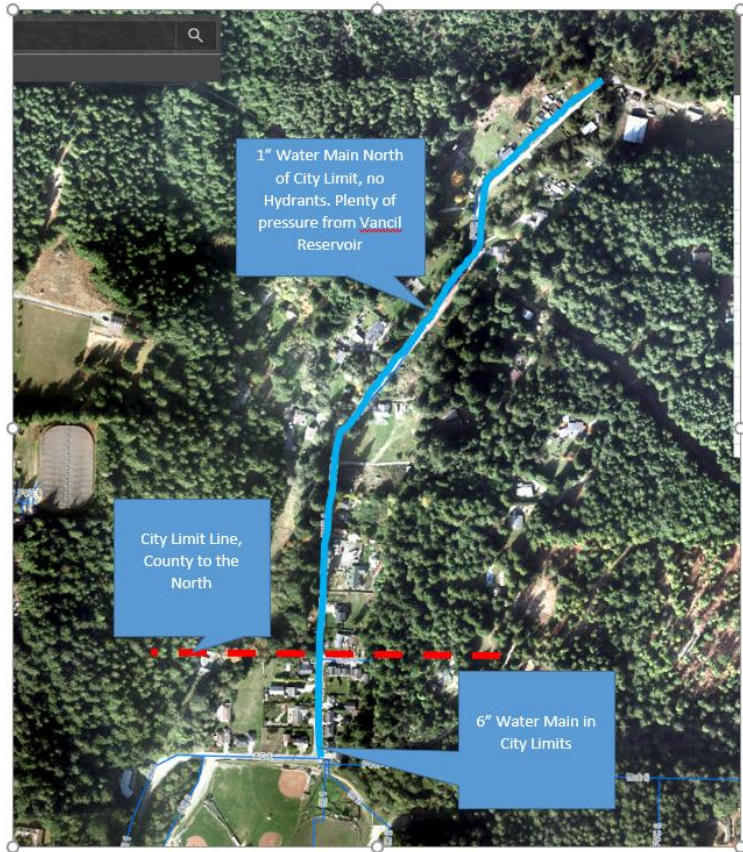

(Utilities Superintendent)

### Project Cost Estimate

2023 Dollars

1. Design	\$80,000	26/27
2. Construction	\$750,000	27/28

**Total**                      **\$830,000**

# Wastewater Treatment and Collections

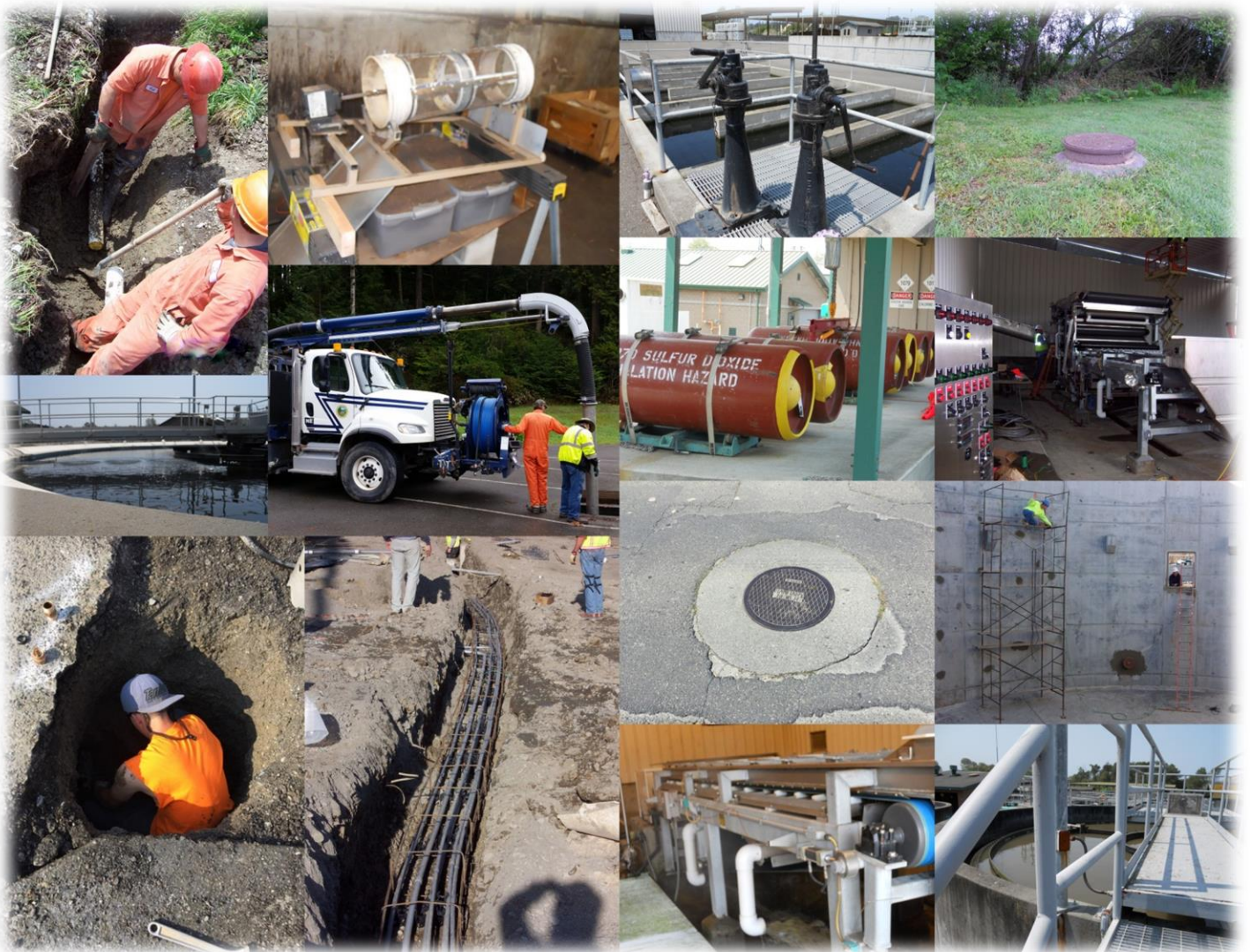



# Sewer System Model and Master Plan

CIP# 9110

## Description

Develop an updated master plan for the sewer system of the entire City.

## Justification

This master plan will provide information that staff can use to identify improvements needed to develop future projects to provide proper capacity and collection of the City's sewer system.

## Studies and Reports

Oscar Larson Sanitary Sewer System Evaluation and Recommended Improvements Report 2011

## Funding Sources

Sewer Reserve Fund 560

## Prior Appropriations

N/A

## Comments

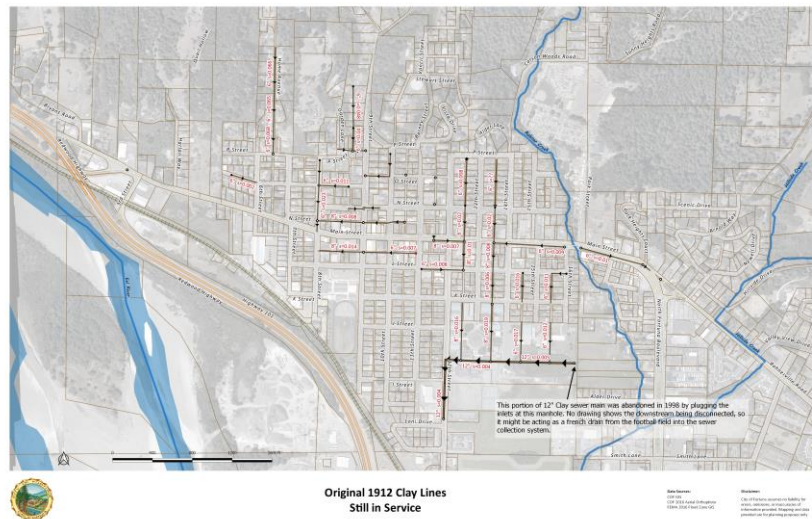
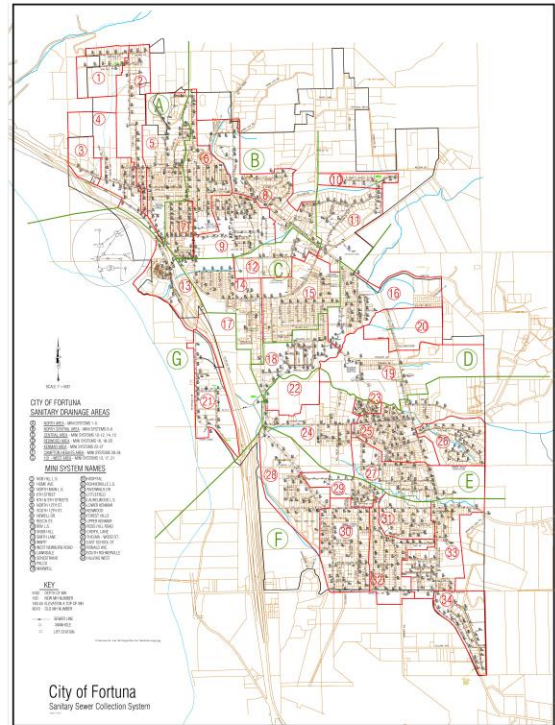

(Director of Public Works)

## Project Cost Estimate

	2023 Dollars	
1. Planning	\$165,000	23/24
<b>Total</b>	<b>\$165,000</b>	

## Description

Perform engineering design and permitting for the treatment plant upgrade and new summertime effluent disposal location. Restrict flows to Strongs Creek to 1% of the creek flow and comply with nutrient effluent limitations. Includes WWTP Equalization Pond Project



## Justification

This project will bring the plant into compliance with the 2016 permit standards set by the Regional Water Quality Control Board.

## Studies and Reports

GHD 2015 Pre-Feasibility Analysis

## Funding Sources

Sewer Reserve Fund 560

## Prior Appropriations

Sewer Reserve Fund 560;  
 Prefeasibility Analysis \$178,709  
 Compliance Project \$440,000  
 SWRCB Grant Fund 360;  
 Compliance Project \$500,000



## Comments

The projected costs below are for complete compliance with the RWQCB including construction, potential property acquisition(s), plant upgrades and design. The estimates will be updated as the analysis is more complete and a clearer picture of the permit is realized.

(City Engineer)

### Project Cost Estimate

	<b>2023 Dollars</b>	
1. Design	\$2,000,000	23/24
2. Construction	\$10,000,000	25/26
3. Construction	\$10,000,000	26/27
<b>Total</b>	<b>\$22,000,000</b>	



# Sanitary Sewer Lining Project

CIP# 9976

## Description

Identify locations and contract for lining of existing sanitary sewer lines at various locations within the City. Includes from 12<sup>th</sup> Street to the parking lot at Forbusco Lumber.

## Justification

The City has aging infrastructure, and especially sewer lines age and crack resulting in inflow from storm water impacting the sewage treatment facility, this will help in alleviating those impacts.



## Studies and Reports

SHN 2018 Sanitary Sewer Evaluation Study

## Funding Sources

Sewer Reserve Fund 560

## Prior Appropriations

\$200,000 grant funds SWRCB for planning

## Comments

2<sup>nd</sup> Avenue was recommended by the SSES as one of the worst sections in the 2018 study.



(Utilities Superintendent)

## Project Cost Estimate

2023 Dollars

1. Design	\$100,000	23/24
2. Construction	\$800,000	24/25

**Total**                      **\$900,000**

# East Downtown Sewer Replacement Project

CIP# 9514

## Description

Replacement of the existing sewer line with 6” SDR 35 (plastic) in the alleys between 14<sup>th</sup> and 15<sup>th</sup> Street as well as 15<sup>th</sup> to 16<sup>th</sup> Street from N Street to P Street. Also on 8<sup>th</sup> Street from P Street to Main Street.

## Justification

The existing line was constructed from clay, which, over time, has led to storm water infiltration of the sewer. Replacing these lines will reduce the cost of treating this water at the wastewater treatment facility.

## Studies and Reports

Identified and recommended by the Utilities Crew.

## Funding Sources

Sewer Reserve Fund 560

## Prior Appropriations

N/A

## Comments

(Utilities Superintendent)



## Project Cost Estimate

2023 Dollars

1. Construction	\$550,000	25/26
-----------------	-----------	-------

<b>Total</b>	<b>\$550,000</b>	
--------------	------------------	--



## Description

Replacement of the existing sewer line with 6” SDR 35 (plastic) on P Street in between Garden and 9<sup>th</sup> Street, including manhole rehabilitations.

## Justification

The existing line was constructed from clay, which over time has deteriorated and been damaged by roots. The damage has led to storm- and ground water infiltration of the sewer. Replacing these lines will reduce the cost of treating this water at the wastewater treatment facility.



## Studies and Reports

Identified and recommended by the Utilities Crew while performing sewer camera inspections in 2022.

## Funding Sources

Sewer Reserve Fund 560

## Prior Appropriations

N/A

## Comments



(Utilities Superintendent)

## Project Cost Estimate

2023 Dollars

1. Construction	\$150,000	23/24
<b>Total</b>	<b>\$150,000</b>	

# Hilltop Sewer Main Project

CIP# TBD

## Description

Extend 6” SDR 35 (plastic) sewer main to include all of Hilltop Drive (approximately 900 feet).



## Justification

Currently the City’s sewer ends at the intersection of Ridgeview and Hilltop. This leaves approximately 30 homes on Hilltop Drive with septic systems. City code requires anyone within 1,000 feet of City sewer to be connected to sanitary sewer system. This project will reduce the inherent ground water pollution sources from septic systems.

## Studies and Reports

Identified by the Utility Superintendent.

## Funding Sources

Future Unidentified Grant Funds

## Prior Appropriations

N/A

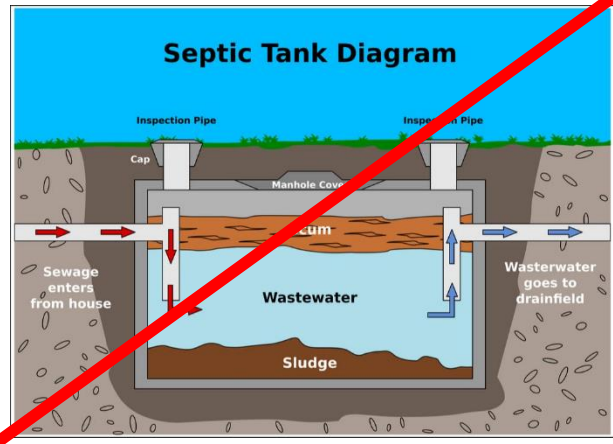

## Comments

(Utilities Superintendent)

### Project Cost Estimate

2023 Dollars

1. Design	\$50,000	26/27
2. Construction	\$450,000	27/28
<b>Total</b>	<b>\$500,000</b>	

# Treatment Plant PLC, VPN, and Hardware Upgrades CIP# TBD

---

## Description

Replace defunct SE Modicon PLC Cards, non-functioning VPN, and rewire PLC cabinets (5 total).

## Justification

Our Modicon PLCs were discontinued in 2020, and their end of life is in 2028. With a new plant upgrade on the way, we need PLCs with extended life that can keep up with our plant until the next upgrade is needed. Our VPN has been non-functional since 2020, and we need secure remote access to our SCADA system at all times. Wiring is optional, but currently some of our cabinets are an unlabeled, or mislabeled, mess. Getting PLC addresses properly labeled and all equipment wired during the plant upgrade can allow for proper future automation, maintenance, and operation of our equipment.

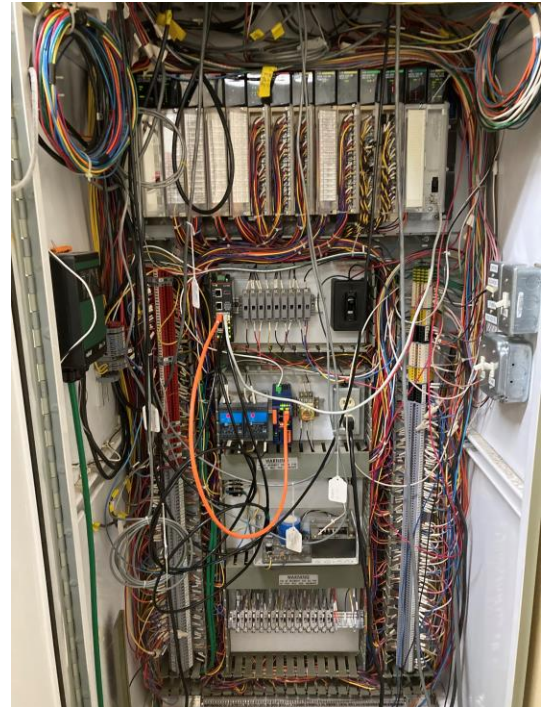

## Studies and Reports

Identified by the assistant city engineer, wastewater operations team, and consulting engineers.

## Funding Sources

TBD

## Prior Appropriations

N/A

## Comments

This project could be combined with the Compliance Project, CIP 0171.

(City Engineer)

---

### Project Cost Estimate

#### 2023 Dollars

1. Design	\$50,000	26/27
2. Construction	\$350,000	27/28

**Total** **\$400,000**



## Description

This CIP would fund a sewer camera contractor to assist the City in cleaning and inspecting gravity sewer lines older than 10-years.

## Justification

The City is required through a settlement agreement with California River Watch to complete CCTV sewer camera inspection of the entire collection system by May 2024. To date City staff have been able to complete inspections of 12 miles of sewer line, however there are approximately 40 miles remaining. This funding would allow the City to contract with a sewer camera specialist to complete the effort

## Studies and Reports

N/A

## Funding Sources

Sewer Fund 560

## Prior Appropriations

Sewer Fund 560: \$250,000

## Comments

City staff will proceed with performing CCTV inspection of as much of the system as possible prior to contracting with a specialist to complete the effort by the compliance date.



(Utilities Superintendent)

## Project Cost Estimate

2023 Dollars

1. Construction	\$600,000	23/24
<b>Total</b>	<b>\$600,000</b>	



# Drainage Systems





# **Stormdrain Infrastructure Vulnerability Assessment Project CIP#9100**

## **Description**

Perform field reconnaissance including visual and camera inspection of the entire stormdrain system in the City. Develop a comprehensive report outlining the condition of each feature and develop funding-ready CIP projects for vulnerable infrastructure.



## **Justification**

The City has a large number of old RCP and CMP pipe in the existing stormdrain system. Old RCP fails at the joints, and old CMP rusts away, frequently resulting in sinkholes or other failures with which the City struggles to keep up on. Many failures happen as a surprise as the conditions of much of the stormdrain system is unknown.

## **Studies and Reports**

Identified and recommended by Engineering/Public Works

## **Funding Sources**

Measure E Fund 101 25%  
FEMA Grant Fund 351 75%

## **Prior Appropriations**

N/A

## **Comments**



(City Engineer)

## **Project Cost Estimate**

**2023 Dollars**

1. Planning	\$70,000	23/24
<b>Total</b>	<b>\$70,000</b>	

# Prop 1 LID 12<sup>th</sup> Street Project

CIP# 9101

## Description

Install raingarden LID basins and new stormdrain pipe along 12<sup>th</sup> Street and in the southern parking lot of Fortuna High School.



## Justification

All drainage conveyance on 12<sup>th</sup> Street north of the High School parking lot is gutter flow. The street floods during relatively small storm events.

## Studies and Reports

Identified and recommended by Engineering/Public Works

## Funding Sources

Measure E Fund 101; 3%  
Grant Fund 352; 97%

## Prior Appropriations

Prop 1E Technical Assistance Grant; \$300,000

## Comments

Construction to begin in FY 2022/23 and be completed in 2023/24.



(City Engineer)

## Project Cost Estimate

2023 Dollars

1. Construction	\$955,000	23/24
<b>Total</b>	<b>\$955,000</b>	

## Description

General yearly maintenance of the City’s stormdrain system in locations to be determined.

## Justification

Many of the storm drains across the City have corrosion damage to the bottom of the corrugated pipe. This project will identify and make repairs as they are needed.



## Studies and Reports

Identified and recommended by General Services Staff.

## Funding Sources

Measure E Fund 101

## Prior Appropriations

Measure E Fund 101; Construction \$636,312

## Comments



(General Services Superintendent)

### Project Cost Estimate

#### 2023 Dollars

1. Construction	\$246,900	23/24
2. Construction	\$200,000	24/25
3. Construction	\$200,000	25/26
4. Construction	\$200,000	26/27
5. Construction	\$200,000	27/28

**Total** **\$1,046,900**



## Description

Replacement of the outfall and culvert at South 15<sup>th</sup> Street.

## Justification

The existing corrugated metal pipe is deteriorated at the flow line (invert). This project will replace the damaged line and outfall to improve drainage and reduce soil erosion.



## Studies and Reports

Identified and recommended by the General Services Crew.

## Funding Sources

Drainage Fund 130

## Prior Appropriations

N/A

## Comments



(General Services Superintendent)

## Project Cost Estimate

2023 Dollars

1. Construction	\$65,000	24/25
<b>Total</b>	<b>\$65,000</b>	

## Description

Replacement of the existing concrete box culvert which runs under the sidewalk with 30” storm drain on Home Avenue from the “S-curve” to P Street.

## Justification

The existing 2’x2’ box culvert is failing and the forming ladders fall into the culvert which results in jams. This project will replace the box culvert which will reduce jams and improve drainage to the surrounding areas.



## Studies and Reports

Winzler & Kelly 2005 Storm Drainage Master Plan

## Funding Sources

Drainage Fund 130

## Prior Appropriations

N/A

## Comments

Preliminary CCTV inspections performed by staff indicates that the drainage structure is in good working order, only minor rehabilitation may be required. Staff to evaluate effort this coming year in coordination with the stormdrain vulnerability assessment

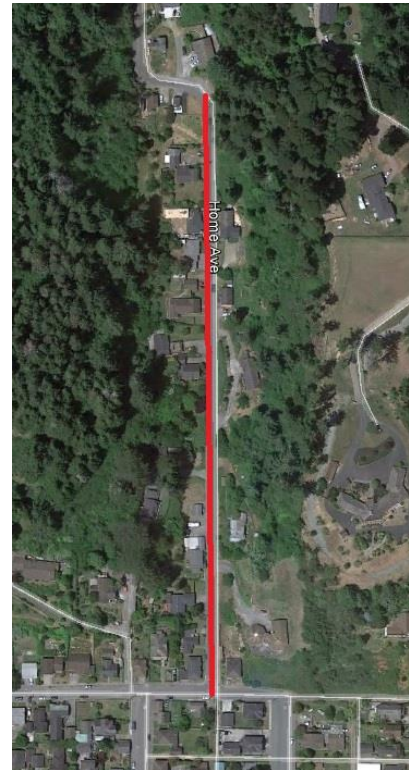

(General Services Superintendent)

## Project Cost Estimate

### 2023 Dollars

1. Design	\$60,000	25/26
2. Construction	\$600,000	26/27
<b>Total</b>	<b>\$660,000</b>	

## Description

Replacement and/or lining of the 30” RCP culvert from Christian Ridge to P Street. Approximate length of culvert is 1,200 feet. Additional drainage inlets for access.

## Justification

The existing reinforced concrete pipe is separating and/or deteriorated causing the surrounding area to form sinkholes. The culvert is alongside or underneath structures. This project will replace the damaged line and outfall to improve drainage and reduce soil erosion.

## Studies and Reports

Identified and recommended by the General Services.

## Funding Sources

Drainage Fund 130  
Measure E Stormdrain Maintenance

## Prior Appropriations

N/A

## Comments



(General Services Superintendent)

### Project Cost Estimate 2023 Dollars

1. Design	\$40,000	24/25
2. Construction	\$400,000	25/26
<b>Total</b>	<b>\$440,000</b>	





## Description

This project is a complete look at the Interchange of Kenmar Road and Highway 101 including vehicular, pedestrian and cycling users.

## Justification

This project will improve the traffic flow and pedestrian & cycling safety at this interchange with Highway 101.

## Studies and Reports

Identified and recommended by the City Engineer.

## Funding Sources

STIP Grant Fund 270

## Prior Appropriations

Complete Streets grant through the Humboldt County Association of Governments provided for a Project Study Report on alternatives to improve this interchange.

STIP Grant Fund 270; \$276,000

## Comments

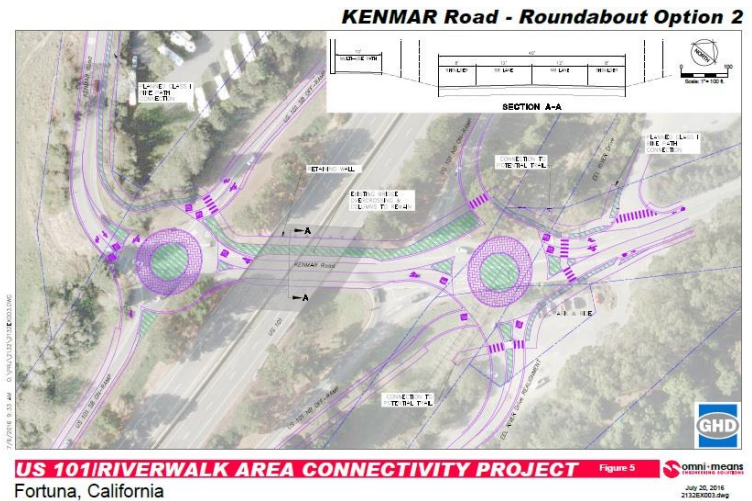

(City Engineer)

### Project Cost Estimate

2023 Dollars

1. Design	\$35,000	23/24
<b>Total</b>	<b>\$35,000</b>	



**Description**

Remove barriers for people with disabilities at various locations in the City including the Library, Bus Stops and Curb Ramps.

**Justification**

The City is continuously removing barriers that might prevent its citizens from being able to use and enjoy City facilities. This project will do a big part in completing this goal.

**Studies and Reports**

2014 ADA transition Plan

**Funding Sources**

CDBG Fund 830

**Prior Appropriations**

CDBG Fund 830

Design; \$42,000

**Comments**



(General Services Superintendent)

**Project Cost Estimate**

**2023 Dollars**

1. Design	\$75,000	23/24
2. Construction	\$785,000	23/24
<b>Total</b>	<b>\$860,000</b>	



## Description

Paving of locations throughout the City as needed and as part of an annual contract.

## Justification

A contract will be taken out annually with a qualified paving contractor who can then provide routine repairs and maintenance for City streets.

## Studies and Reports

Identified and recommended by the General Services Crew.

## Funding Sources

Measure E Fund 101; 55%

RSTP Fund 275; 45%

Other funds may be used as determined to be appropriate by project.

## Prior Appropriations

Measure E Fund 101

TDA Fund 140

LTF Fund 260

## Comments

Annual maintenance project based on need, locations to be identified by staff.



(General Services Superintendent)

## Project Cost Estimate

### 2023 Dollars

1. Construction	\$225,000	23/24
2. Construction	\$225,000	24/25
3. Construction	\$225,000	25/26
4. Construction	\$225,000	26/27
5. Construction	\$225,000	27/28

**Total**                      **\$1,125,000**

## Description

Street slurry at multiple locations throughout the City of Fortuna.

## Justification

This project is part of the regular maintenance and will seal the road surface and extend the life of the existing roadway.

## Studies and Reports

Identified and recommended by the General Services Crew.

## Funding Sources

RSPT Fund 275

## Prior Appropriations

## Comments

Locations to be determined annually by need. This is a county-wide collaborative project that allows for an economy of scale and a better price for Fortuna’s citizens. Next anticipated project will be in calendar year 2024.

(General Services Superintendent)



## Project Cost Estimate

	<b>2023 Dollars</b>	
1. Construction	\$50,000	23/24
2. Construction	\$50,000	24/25
3. Construction	\$50,000	25/26
4. Construction	\$50,000	26/27
5. Construction	\$50,000	27/28
<b>Total</b>	<b>\$250,000</b>	

## Description

Repair of sidewalk and curb locations throughout the City as needed and as part of an annual contract.

## Justification

A contract will be taken out annually with a qualified concrete contractor who can then provide routine repairs and maintenance for City curbs, gutters, and sidewalks on an on-call basis.

## Studies and Reports

Identified and recommended by the General Services Crew.

## Funding Sources

RSTP Fund 275

## Prior Appropriations

Local Transportation Fund 260;  
RSTP Fund 275

## Comments

Locations will be identified as needed.



(General Services Superintendent)

## Project Cost Estimate

2023 Dollars

1. Construction	\$50,000	23/24
2. Construction	\$50,000	24/25
3. Construction	\$50,000	25/26
4. Construction	\$50,000	26/27
5. Construction	\$50,000	27/28

**Total**                      **\$250,000**



## Description

Paving and other maintenance improvements throughout the City as identified by staff on an annual basis.

## Justification

The state of California passed SB1, the Road Maintenance and Rehabilitation Account in 2017, resulting in funds which are allocated to the City annually, to which projects are identified each year.

## Studies and Reports

Pavement Condition Index document by Nichols Consulting Engineers.

## Funding Sources

SB1 Fund 290

## Prior Appropriations

Annual appropriations vary.

## Comments

Locations will be identified as needed.



(General Services Superintendent)

## Project Cost Estimate

### 2023 Dollars

1. Construction	\$309,500	23/24
2. Construction	\$275,000	24/25
3. Construction	\$275,000	25/26
4. Construction	\$275,000	26/27
5. Construction	\$275,000	27/28

**Total**                      **\$1,409,500**

## Description

Install 760 lineal feet of curb and sidewalk along Rohnerville Road near North Loop Road. The sidewalk will be adjacent to the retaining wall and incorporate drainage.

## Justification

City staff has received complaints on the safety of pedestrians that walk along that side of the roadway.

## Studies and Reports

Identified to be part of the John Campbell Memorial Greenway.

## Funding Sources

Measure E Fund 101

## Prior Appropriations

N/A

## Comments

This project may be partially funded by a private donation.



(General Services Superintendent)

### Project Cost Estimate

2023 Dollars

1. Construction	\$60,000	26/27
<b>Total</b>	<b>\$60,000</b>	



**Description**

This project is to design and complete a project to increase the level of service of this intersection, and to provide for increase non-motorized access across the intersection.

**Justification**

This intersection currently operates with a low level of services, and creates congestion issues along all legs of the intersection during peak times. Pedestrian crossing facilities across most legs of the intersection are unsafe. This project would complement the improvements proposed in CIP #9978.

**Studies and Reports**

Identified and recommended by the City Engineer. The City is in the process of performing a Project Study Report for the intersection to help guide and budget for a recommended improvement

**Funding Sources**

Future Funding TBD

**Prior Appropriations**

\$44,000 from Fund 140

**Comments**

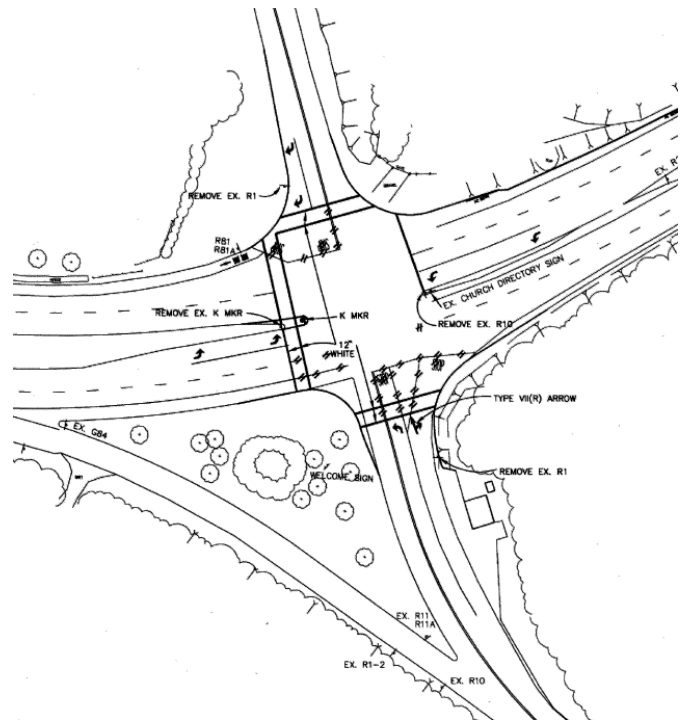

(City Engineer)

**Project Cost Estimate  
2023 Dollars**

Future Funding and Project Costs to be Determined



**Description**

This project is a complete look at the Interchange of 12<sup>th</sup> Street, Newburg Road and Highway 101 including vehicular, pedestrian and cycling users. The project would also investigate ways to expand non-motorized access on the Highway 101 overpass.

**Justification**

This project will improve the traffic flow and pedestrian & cycling safety at this interchange with Highway 101. The existing interchange has several geometric and safety deficiencies and is currently underperforming per the City’s General Plan LOS targets.

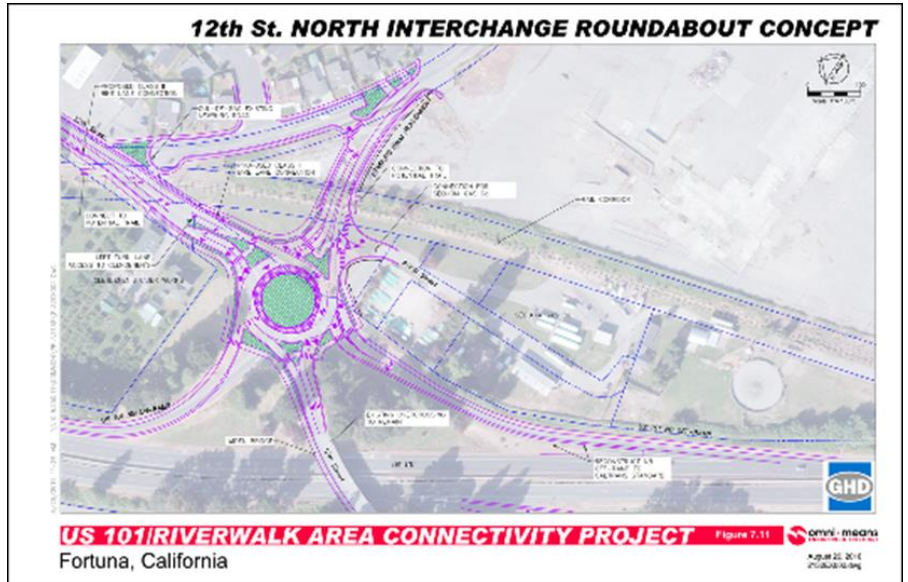

**Studies and Reports**

2016 Complete Street Planning Study  
Local Road Safety Plan

**Funding Sources**

Caltrans STIP Grant Fund 270

**Prior Appropriations**

N/A

**Comments**

(City Engineer)



**Project Cost Estimate**

2023 Dollars

1. Design	\$825,000	23/24
<b>Total</b>	<b>\$825,000</b>	

**Description**

Replacing the hardware in the traffic light cabinets for the Main Street, Newburg, and Redwood Way intersections. Upgrading the signal heads, pedestrian push buttons, and crosswalks on the Newburg Road intersection.

**Justification**

The signal heads on the Newburg intersection light are smaller than current standards. The control cabinets have outdated hardware and signal timing design needs to be revisited for current traffic conditions. The City’s 2021 Local Road Safety Plan recommended a number of improvements to the Newburg intersection including signal improvements and bike/pedestrian access improvements.

**Studies and Reports**

Local Road Safety Plan  
2016 Complete Streets Connectivity Study

**Funding Sources**

Traffic Impact Fund 140  
Unidentified Grant Funds

**Prior Appropriations**

N/A

**Comments**

(General Services Superintendent)



**Project Cost Estimate  
2023 Dollars**

1. Design	\$10,000	23/24
2. Construction	\$65,000	23/24
<b>Total</b>	<b>\$75,000</b>	

# Newburg Road Sidewalk ADA Barrier Removal Project CIP# TBD

## Description

To remove and replace 24 driveway approaches and replace in compliance with standard building codes. Remove and replace 6 street corners in compliance with standard building codes and relocated posted sign locations.

## Justification

Path of travel has ADA barriers.

## Studies and Reports

Identified and recommended by the General Services Superintendent.

## Funding Sources

Regional Surface Transportation Program Fund 275

## Prior Appropriations

N/A

## Comments



(General Services)

### Project Cost Estimate 2023 Dollars

1. Construction	\$300,000	26/27
<b>Total</b>	<b>\$300,000</b>	







**Description**

Readily available funds for acquiring additional park spaces for public use or for general park improvements.

**Justification**

Often the City has multiple general projects identified that might include land acquisition, assistance with engineering, drafting, conceptual design, grant writing, etc. in which funds may need to be readily available in order to pursue new opportunities in a timely fashion and in order to enhance and expand park spaces for public use.

**Studies and Reports**

Identified and recommended by the Parks Director.

**Funding Sources**

Prop 68 Rural Recreation and Tourism (RRT) or Regional Park Program (RPP) grants, Measure E Fund 101.

**Prior Appropriations**

N/A

**Comments**

No CIP specific funding for FY 2023/24. Any efforts on this project will be funded using the general park acquisition and improvement account, funded by Measure E.

**Riverwalk Recreational Area**



(Parks Director)

**Project Cost Estimate**

	<b>2023 Dollars</b>	
1. Planning	\$3,000,000	25/26
<b>Total</b>	<b>\$3,000,000</b>	

# Rohner Park Basketball Court Reconstruction Project CIP#9106

---

## Description

Rehabilitation of an existing outdoor basketball court and the addition of a second, identical basketball court in Rohner Park. These new courts would have updated surfacing, new backboards, rims, posts, as well as perimeter fencing.

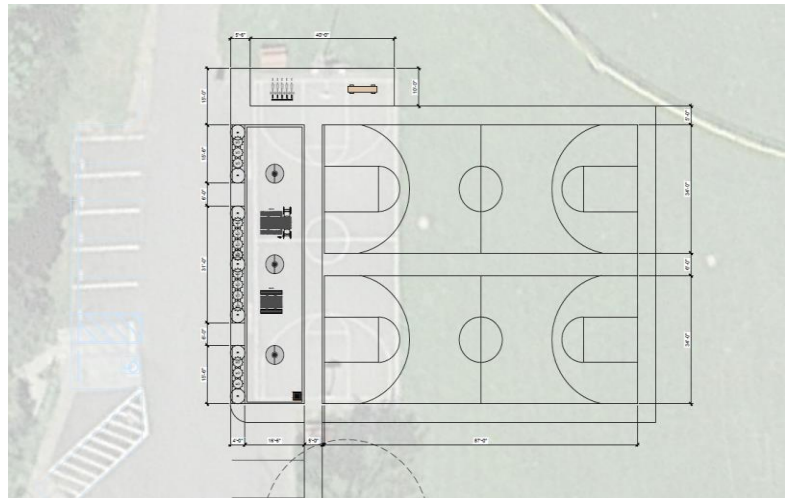

## Justification

This project was requested by the public during Measure E project identification and through public outreach related to Proposition 68 grant projects in 2019 and 2020. Currently, only one public outdoor basketball exists in Rohner Park, which has become outdated, so there exists a desire to expand and improve outdoor court use to meet the demand of the public for additional places to play outdoor basketball.



## Studies and Reports

Identified and recommended by the Parks Director.

## Funding Sources

Measure E Fund 101 – 100%

## Prior Appropriations

N/A

## Comments

(Parks Director)

---

## Project Cost Estimate

	<b>2023 Dollars</b>	
1. Design/Construction	\$80,000	23/24
<b>Total</b>	<b>\$80,000</b>	



# River Lodge Exterior Staining Project

CIP# TBD

## Description

The exterior stain on the River Lodge has become faded, so an application of staining is required to enhance the aesthetics of the facility.

## Justification

This improvement project would enhance the River Lodge by creating a more desirable facility that would draw users wanting to host events, conferences, meetings, or banquets; resulting in higher revenues to the General Fund.

## Studies and Reports

Identified and recommended by the Parks Director.

## Funding Sources

TBD

## Prior Appropriations

N/A

## Comments



(Parks Director)

## Project Cost Estimate

2023 Dollars

1. Construction	\$35,000	23/24
<b>Total</b>	<b>\$35,000</b>	

**Generators for Park 5, Firemen’s Pavilion and Museum Project CIP# TBD**

**Description**

A generator that would have the ability to power the Firemen’s Pavilion, the Rohner Rec Hall, the Parks & Recreation Office, and the Depot Museum. All facilities are in-line and could be powered by one generator, in case of a power outage.



**Justification**

Currently, if a power-outage occurs, all electrical to these facilities ceases to be available. This makes it difficult for, not only City staff to be able to work efficiently on projects that require electricity, but for facility renters and park users who have access to these facilities, which can result in lost staff time, and lost revenue from facilities having to be closed due to no power.

**Studies and Reports**

Identified and recommended by the Parks Director.

**Funding Sources**

Measure E Fund 101

**Prior Appropriations**

N/A

**Comments**



(Parks Director)

**Project Cost Estimate**

**2023 Dollars**

1. Construction	\$90,000	24/25
<b>Total</b>	<b>\$90,000</b>	

**Description:**

Readily available funds for developing an additional park space for public use and for general park improvements.

**Justification:**

The City purchased an adjacent 8.4-acre parcel to the southeast of the existing park in December of 2021 using combined City and RCRPD Prop 68 Per Capita funding.

There will be various, multi-phased projects to develop this site for recreational use, as funding opportunities become available. This may include assistance with engineering drafting, conceptual design, grant writing, land development, etc. in which funding may need to be readily available in order to pursue new opportunities in a timely fashion to expand this park space for public use, as the public has already identified desired park features (2019).

**Studies and Reports**

Identified and recommended by the City Manager and Parks & Recreation Director. Greenway Partners public outreach and conceptual design completed in 2019.

**Funding Sources:**

Measure E Fund 101, grants

**Prior Appropriations**

Prop 68 Per Capita land purchase; \$340,000  
Greenway Partners; \$21,000

(Parks Director)



**Project Cost Estimate**

**2023 Dollars**

1. Design and Construction	\$900,000	23/24
<b>Total</b>	<b>\$900,000</b>	





# Land and Buildings



# Police Facility Replacement Project

CIP# 9104

## Description

Remodel existing building at 2600 Rohnerville Road for the purposes of a permanent police facility.

## Justification

The current facility has insufficient space to be able to conduct department business in an efficient and effective manner.



## Studies and Reports

ELA Police Facility Needs Assessment Study, 2020  
Fortuna Police Facility Needs Assessment, LMA 2015

## Funding Sources

General Fund 100:  
Measure E:

## Prior Appropriations

Design contract with Whitchurch Engineering - \$55K

## Comments

The City purchased two parcels at 2600 Rohnerville Road and 2650 Rohnerville Road for the purposes of construction of a future police facility. A long-term solution was identified that was expected to cost approximately \$2M. This project would be a remodel of the existing building to meet the short-term needs of the department and nearly double the usable space that they have available now.



(City Manager)

## Project Cost Estimate

	2023 Dollars	
1. Construction	\$2,425,000	23/24
<b>Total</b>	<b>\$2,425,000</b>	



# Infrastructure Modernization & Energy Efficiency Project CIP#TBD

## Description

The City intends to select a qualified provider for the development, implementation, and monitoring of a comprehensive infrastructure modernization and utility savings program (i.e. solar panels) for locations throughout the City.



## Justification

The City’s ultimate goal is to utilize financial savings realized from more efficient facilities towards other upgrades and programs that enhance the working environment and improve livability for Fortuna residents.

## Studies and Reports

Identified and recommended by the Deputy Public Works Director.

## Funding Sources

Future Unidentified Grant Funds

## Prior Appropriations

N/A

## Comments



(Deputy Director of Public Works)

### Project Cost Estimate

2023 Dollars

1. Construction	\$1,000,000	25/26
<b>Total</b>	<b>\$1,000,000</b>	



# Vehicle Charging Station Project

CIP# TBD

## Description

Installation of vehicle charging stations at several locations throughout Fortuna.

## Justification

City of Fortuna currently has three charging stations located on 11<sup>th</sup> Street. This project would provide charging stations for citizens that purchase electric vehicles and wish to reduce their carbon footprint. Charging stations would be provided at the River Lodge Conference Center, N Street public parking lot, Rohner Park, the Corp Yard and Newburg Park.



## Studies and Reports

Identified and recommended by General Services Superintendent.

## Funding Sources

Unidentified Grant Funds

## Prior Appropriations

N/A

## Comments



(General Services Superintendent)

## Project Cost Estimate

2023 Dollars

1. Construction

\$150,000

24/25

**Total**

**\$150,000**

## Description

Install a new natural gas backup power generator and Automatic Transfer Switch at the City’s Corporation Yard.

## Justification

Currently there is no backup power at the City’s Corporation Yard during a power outage. During outages or emergencies, the City’s operations at the facilities are fully without power and light.



## Studies and Reports

N/A

## Funding Sources

49% USDA Grant 500

25.5% Fund 510

25.5% Fund 560

## Prior Appropriations

N/A

## Comments

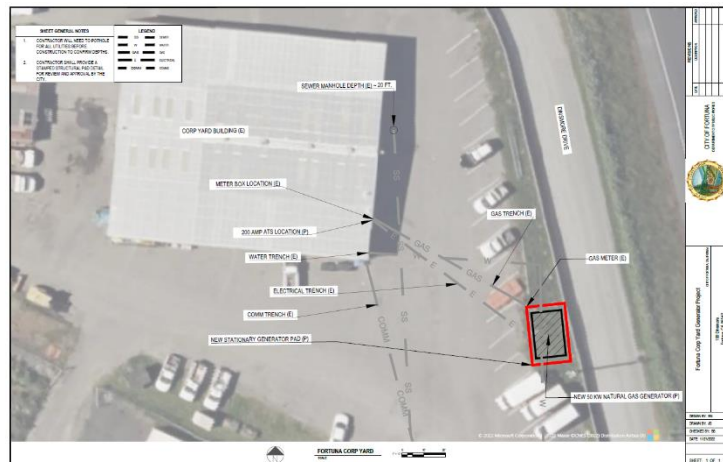

(General Services Superintendent)

## Project Cost Estimate

2023 Dollars

1. Construction	\$90,000	23/24
-----------------	----------	-------

<b>Total</b>	<b>\$90,000</b>
--------------	-----------------

## Description

The Monday club Chimney was damaged in the December 2022 earthquake. Immediately following the damage, staff worked with a local contractor to demolish sections of the chimney to make the building safe. The chimney now requires full demolition and reconstruction.

## Justification

The Monday Club is an iconic piece of downtown infrastructure, and restoring its look is important. Additionally, the gas fireplace insert inside the building cannot be used until the chimney has been repaired.

## Studies and Reports

N/A

## Funding Sources

Staff anticipate that the City’s insurance policy/risk pool will cover the cost of demolition and reconstruction



## Prior Appropriations

N/A

## Comments

(City Engineer)

### Project Cost Estimate 2023 Dollars

1. Construction	\$TBD	23/24
<b>Total</b>	<b>\$TBD</b>	



# Corp Yard Roofing Project

CIP# 9969

## Description

Replace the metal roofing on the metal building at the City's Corporation yard.

## Justification

The roof to this building has been identified for removal for the previous five years. Storage of exposed materials is resulting in rusted and wasted materials.

## Studies and Reports

Identified and recommended by the General Services Superintendent and Utilities Superintendent.

## Funding Sources

Water Reserve Funds 510 50%  
Sewer Reserve Funds 560 50%

## Prior Appropriations

N/A

## Comments

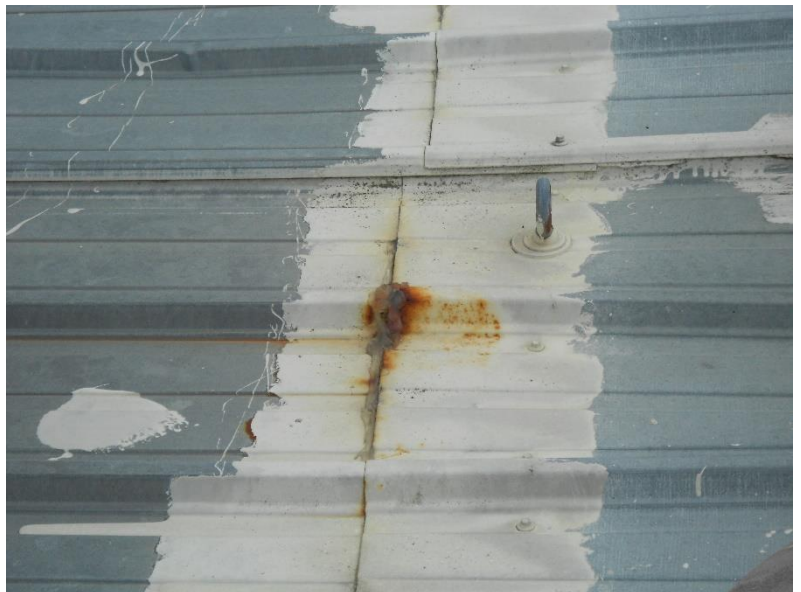
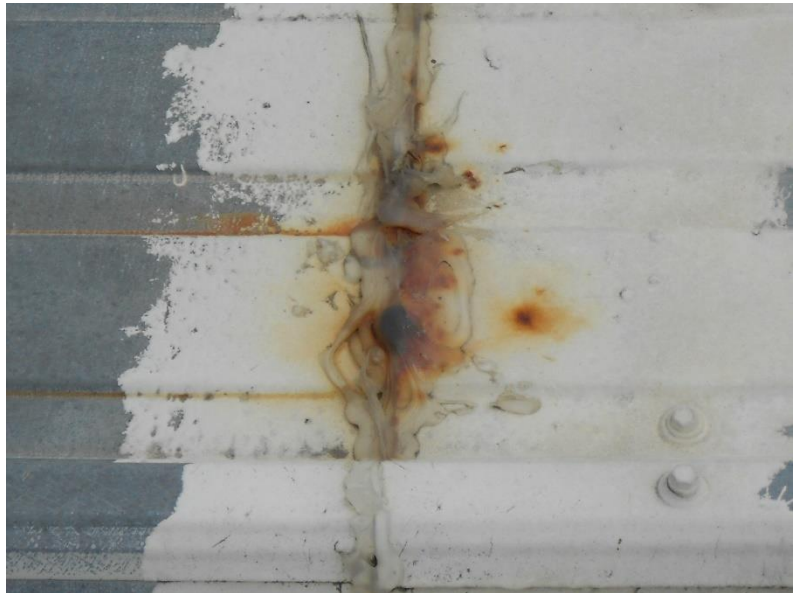

(General Services Superintendent)

## Project Cost Estimate

2023 Dollars

1. Construction	\$60,000	23/24
<b>Total</b>	<b>\$60,000</b>	

## Completed and In Progress Projects

This list contains the CIP projects that were completed by the City of Fortuna in the 2022/2023 fiscal year, as well as their cost estimates and actual costs. This list does not include projects that will continue over into the 2023/2024 fiscal year.

*Table 1. Project completed in FY 22/23.*

<b>Dept.</b>	<b>Project Name</b>	<b>Funding Source</b>	<b>Estimated Cost</b>	<b>Actual Cost</b>	<b>% Variance</b>
PW	Jameson Creek Fish Passage Improvement Project	WCB and CDFW Grants	\$2,702,990	\$2,428,943	-11%